

CHEM C2000

250
EXPERIMENTS



Please observe the safety information, the advice for supervising adults on page 5, the safety rules on page 6, the information about hazardous substances and mixtures (chemicals) on pages 7-9 and their environmentally sound disposal on pages 123-124, the safety for experiments with batteries on page 7, the first aid information on the inside front cover and the instructions on the use of the alcohol burner on pages 12-13.

WARNING. Not suitable for children under 11 years. For use under adult supervision. Contains some chemicals which present a hazard to health. Read the instructions before use, follow them and keep them for reference. Do not allow chemicals to come into contact with any part of the body, particularly the mouth and eyes. Keep small children and animals away from experiments. Keep the experimental set out of the reach of children under 11 years old. Eye protection for supervising adults is not included.

WARNING — Chemistry Set. This set contains chemicals and parts that may be harmful if misused. Read cautions on individual containers and in manual carefully. Not to be used by children except under adult supervision.



First Aid Information

When conducting experiments with chemicals and in case any accidents should happen during experimentation:

In case of injury, seek immediate medical help.

1. **In case of eye contact:** Wash out eye with plenty of water, holding eye open if necessary. Rinse from the nose outward. Seek immediate medical advice.
2. **If swallowed:** Wash out mouth with water, drink some fresh water. Do not induce vomiting. Seek immediate medical advice.
3. **In case of inhalation:** Remove person to fresh air. For example, move person into another room with open windows or outside.
4. **In case of skin contact and burns:** Wash affected area with plenty of water for at least 10 minutes. Cover burns with a bandage. Never apply oil, powder, or flour to the wound. Do not lance blisters. For larger burns, seek immediate medical help.
5. **In case of doubt, seek medical advice without delay.** Take the chemical and its container with you.
6. **In case of injury always seek medical advice.**
7. **In case of cuts:** Do not touch or rinse with water. Do not apply any ointments, powders or the like. Dress the wound with a germ-free, dry first-aid bandage. Foreign objects such as glass splinters should only be removed from the wound by a doctor. Seek medical advice if you feel a sharp or throbbing pain.

Poison Control Centers (United States)

In case of emergency, your nearest poison control center can be reached everywhere in the United States by dialing the number:

1-800-222-1222

Local Hospital or Poison Centre (Europe)

Record the telephone number of your local hospital or poison centre here:

Write the number down now so you do not have to search for it in an emergency.

Warning! Contains functional sharp points or edges that pose a risk of injury. Keep the packaging and instructions as they contain important information.



Substance/mixture

- is flammable
- is self-igniting
- forms flammable gases with water



Substance/mixture

- may intensify fire (is an oxidizer)



Substance/mixture causes

- corrosion (destruction) of metals
- burns on skin
- severe eye damage



Substance/mixture is

- acutely harmful if swallowed, in contact with skin, or inhaled
- an irritant to skin, eyes and respiratory tract
- sensitizing to skin
- narcotic



Substance/mixture

- has life-threatening acute toxicity
- is acutely toxic if swallowed, if on skin, or if inhaled



Substance/mixture is

- acutely very toxic
- very toxic or toxic with long lasting effects to aquatic life

Brief Explanation of the GHS Hazard Pictograms

The chart to the left shows the Globally Harmonized System (GHS) pictograms. The text under each symbol cites dangers associated with substances that are designated with the pictogram.

A substance/mixture designated with a pictogram may be associated with one or more of the hazards listed under that pictogram. For example, copper sulfate (exclamation point) is harmful and irritant. You can find out exactly what hazards are associated with a certain substance in this kit by referring to the list on pages 7 to 9.

CHEM C2000

Experiment Manual

Kurt Waselowsky

Franckh-Kosmos Verlags-GmbH & Co. KG, Stuttgart, Germany
Thames & Kosmos, LLC, Providence, RI, USA

1st Edition © 2011 Franckh-Kosmos Verlags-GmbH & Co. KG, Stuttgart, Germany

This work and all parts thereof are protected by copyright. Any use beyond the narrow limits of copyright law without the consent of the publisher is prohibited and punishable by law. This applies in particular to reproductions, translations, microfilming and storage and processing in electronic systems. We do not guarantee that all of the information in this work is free of proprietary rights.

Text: Kurt Waselowsky

Project management: Sonja Brinz

Product development: Monika Schall

Design and illustration: Friedrich Werth, Horb

Photos for packaging and materials: pro-studios, Michael Flaig, Stuttgart

Photos for manual: KOSMOS-Archiv, Stuttgart. Werthdesign, Horb. Various image publishers. For all other images, the source is named in the caption.

The publisher has made an effort to locate the holders of image rights for all of the photos used. If in individual cases a holder of image rights has not been taken into account, they are asked to provide evidence to the publisher of their image rights so that an image fee in line with the industry standard can be paid to them.

4th English Edition © 2011, 2013, 2016, 2020 Thames & Kosmos, LLC, Providence, RI

© Thames & Kosmos is a registered trademark of Thames & Kosmos, LLC.

Translation: David Gamon and Chris Scogrum; Editing: Ted McGuire; Additional Graphics and Layout: Dan Freitas

Distributed in North America by Thames & Kosmos, LLC. Providence, RI 02903

Phone: 800-587-2872; Web: www.thamesandkosmos.com

We reserve the right to make technical changes.

Printed in Germany / Imprimé en Allemagne

Contents

Safety and Precautions

First Aid Information	Inside front cover
Poison Control Contact Information	Inside front cover
Advice for Supervising Adults	5
What you need to know about chemistry experiment kits and using them	
Safety Rules for Chemical Experiments	6
Safety for Experiments with Batteries	7
Hazardous Substances and Mixtures (Chemicals)	7
How they are labeled and how to properly handle them	
Instructions for Using the Protective Goggles	Inside back cover



The Experiments

1. Chemistry Is Everywhere	10
2. Workplace and Equipment	11
3. Without Water There Is No Life — And No Chemistry	16
4. Fresh Air for our Lungs	26
5. Acids, Bases, Salts	36
6. The Greenhouse Gas from a Soda Bottle	46
7. Sulfur Dioxide and Acid Rain	54
8. From Table Salt to Chlorine Chemistry	59
9. Baking Soda and Washing Soda: Two CO₂ Stockpiles	65
10. Quicklime and Plaster: Not just for Building	71
11. The Salt of Amun Ra	77
12. Iron: #1 Commercial Metal	83
13. Copper: The Bright Red Semiprecious Metal	88
14. Colorful Chemistry on Paper	94
15. Sugar and Starch: Two Fattening Foods?	100
16. Protein: Not just in Chicken Eggs	106
17. Water, Fats, and Surfactants	111
18. Luminol: The Cold Light	117



Appendix

19. How to Dispose of Waste	123
20. Answers to the Questions	125
21. Index	127

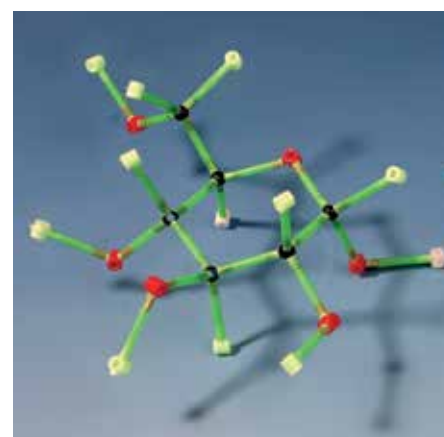



CHEM C2000 contains the following parts:

No.	Description	Item No.	No.	Description	Item No.
1	Protective goggles (Safety glasses)	717019	29	Sodium hydrogen sulfate, 25g	772503
2	Three conducting wires and copper wire (in bag)	773610	30	Sodium carbonate, 12g	772504
3	Two large graduated beakers	087077	31	Potassium hexacyanoferrate(II), 4g	772505
4	Two lids for graduated beakers	087087	32	Calcium hydroxide, 8.5g	772506
5	Funnel	086228	33	Ammonium chloride, 10g	772508
6	Alcohol burner consisting of		34	Potassium permanganate mixture (potassium permanganate-sodium sulfate mixture 1:2 m/m), 10g	775526
7	Burner base	061117	35	Sulfur, 4.5g	772524
8	Insulating piece	048067	36	Copper(II) sulfate, 8g	772522
9	Aluminum disk	021787	37	Litmus powder, 1g	772502
10	Wick holder	021777	38	Magnesium strip	772500
11	Wick	051056	39	Luminol mixture (luminol-sodium sulfate mixture 5% m/m), 3g	772513
12	Burner cap	021797	40	Potassium hexacyanoferrate(III), 6g	772514
13	Rubber stopper without hole	071078	41	Filter paper sheets (not pictured)	702842
14	Rubber stopper with hole	071028			
15	Cork stopper with hole	071118			
16	Safety cap with dropper insert for litmus bottle	704092			
17	Clip for 9-volt battery	712310			
18	Five test tubes	062118			
19	Test tube stand	070187			
20	Two dropper pipettes	232134			
21	Carbon electrode	026217			
22	Pointed glass tube	065308			
23	Angled tube	065378			
24	Immersion heater	065458			
25	Test tube brush	000036			
26	Test tube holder	000026			
27	Double-headed measuring spoon	035017			
28	Lid opener	070177			
	Small bottle for litmus solution	771501			

Divide the polystyrene tray here with a knife (see p. 11)

Keep the packaging and instructions, as they contain important information.

Please check whether all of the parts and chemicals listed in the parts list are contained in the kit.

How can individual parts be reordered?

Contact Thames & Kosmos customer service to inquire about an order.

Additional materials required

On page 14, we have made a list of the additional materials required for a number of experiments.

Safety Information

Information for Supervising Parents and Adults

What you need to know about chemistry experiment kits and using them

Has your child already had the chance to experiment with a beginner's chemistry set? Has he or she marveled over sudden changes in color, or had fun with effervescence or bubbles of gas when you poured water over baking powder mixtures? If so, your child has already started to become familiar with the world of chemical substances. But even if the first encounter with chemistry was in school or with friends, it's never too late for a hands-on introduction into a newly acquired area of interest. CHEM C2000 has just the right equipment for any child who likes to experiment and also wants to learn to decipher the secrets hidden in chemical formulas.

Like all Thames & Kosmos experiment kits, CHEM C2000 assumes no prior knowledge. All of the work techniques are described in complete detail, and all important concepts are thoroughly explained. Safety alone would require this, but it is also necessary for providing an effective learning experience.

With a chemistry experiment kit, you will of course be wondering about the issue of safety. You know that improper use of chemicals can lead to injuries or other health risks. This kit complies with all applicable US consumer product safety regulations, including those for chemistry sets. Moreover, this kit complies with the more rigorous European safety standard EN 71-4, in which the safety requirements for chemistry experimental kits are established, to reduce risks to a minimum. This standard forms the reliable basis of all Thames & Kosmos chemistry experiment kits. The standard contains requirements for the manufacturer, for example that no particularly hazardous substances can be used. They also require the manufacturer, however, to carefully inform the parents or adult supervisors of the possible hazards and to require them to accompany their children in their new hobby with a helping hand. Therefore, please read all of the safety information prescribed by EN 71-4 listed in the box on the right as well as the advice below. Emphasize to your child the importance of following all of this information, and the importance of carrying out only those experiments that are described in this manual.

The safety rules (pages 6 – 7), the information about hazardous substances and mixtures (pages 7 – 9), and the safety information accompanying the experiments inform you of the risks and help you to estimate the suitability of the experiments for your child. In case anything should happen, please find the first aid information and the poison control center contact information on the inside front cover. To avoid injuries, please inform your child of how to handle glass tubes as described on page 12 (inserting it into the rubber stop and removing it from the stopper), how to use the alcohol burner (pages 12 – 13), and how to heat liquids in the test tubes (Experiments 1 and 2). Please fill the burner with alcohol yourself.

Setting up the working area is described on page 11 and the proper waste disposal on pages 123 – 124. A list of additionally required materials can be found on page 14.

We propose that you carry out the experiments in the prescribed order, because the knowledge of working techniques described in the earlier experiments is a prerequisite for the later ones.

We hope your young chemist, and you as well, have a lot of fun and success with the experiments.

Tips and information for you and the child performing experiments:

- Safely rules (p. 6 – 7)
- Hazardous substances and mixtures/chemicals (p. 7 – 9)
- Setting up the work area (p. 11)
- Handling denatured alcohol and operating the alcohol burner (p. 12 – 13)
- Handling glass tubes (p. 13 – 14)
- Additional materials required (p. 14)
- Preparation of the litmus solution (p. 36)
- Proper waste disposal (p. 123 – 124)
- Information about safety glasses (inside back cover)
- First aid information (inside front cover)
- Poison control centers (inside front cover)

Advice for Supervising Adults

- Read and follow these instructions, the safety rules and the first aid information, and keep them for reference.
- The incorrect use of chemicals can cause injury and damage to health. Only carry out those experiments which are listed in the instructions.
- This experimental set is for use only by children over 11 years.
- Because children's abilities vary so much, even within age groups, supervising adults should exercise discretion as to which experiments are suitable and safe for them. The instructions should enable supervisors to assess any experiment to establish its suitability for a particular child.
- The supervising adult should discuss the warnings and safety information with the child or children before commencing the experiments. Particular attention should be paid to the safe handling of acids (e.g. citric acid), alkalis (bases, e.g. sodium carbonate) and flammable liquids (denatured alcohol).
- The area surrounding the experiment should be kept clear of any obstructions and away from the storage of food. It should be well lit and ventilated and close to a water supply. A solid table with a heat resistant top should be provided (also see page 11).
- Instructions for the use of the burner (see pages 12 – 13).

Safety Rules

All of the experiments that are described in this manual can be performed without danger if you carefully follow the tips and rules summarized below.

Safety rules for chemical experiments

- 1. Read these instructions before use, follow them and keep them for reference.** Pay special attention to the quantity specifications and the sequence of the individual tasks. Only perform experiments that are described in this instruction manual.
- 2. Keep young children, animals and those not wearing eye protection away from the experimental area.**
- 3. Always wear eye protection.** If you wear corrective eyeglasses, you will need protective goggles for those who wear eyeglasses. When working, wear appropriate protective clothing (old smock and smooth fingered gloves).
- 4. Store this experimental set out of reach of children under 11 years of age.** As well as the additional materials, for example in a lockable cabinet.
- 5. Clean all equipment after use.**
- 6. Make sure that all containers are fully closed and properly stored after use.**
- 7. Ensure that all empty containers are disposed of properly.**
- 8. Wash hands after carrying out experiments.** Chemicals that accidentally get onto your skin must be rinsed off immediately under running water.
- 9. Do not use any equipment which has not been supplied with the set or recommended in the instructions for use.**
- 10. Do not eat or drink in the experimental area.** Do not use any eating, drinking or other kitchen utensils for your experiments unless it is specifically recommended. Any containers or equipment you use in your work should not be used in the kitchen afterwards. Dispose of used drinking straws in the garbage immediately after the experiment. Do not save and reuse them.
- 11. Do not allow chemicals to come into contact with the eyes or mouth.**
- 12. Do not replace foodstuffs in original container. Dispose of immediately (in the household trash or the sink). If you are investigating food products (e.g., sugar, flour, table salt), fill the required amount into one of the graduated beakers (do not use the double-headed measuring spoon for this). Make note on the beaker of what it contains and the date it was filled.**
13. During the experiments with open flame, be sure that there are no flammable objects or liquids nearby. Extinguish the flame at the end of the experiment at the latest as well as when you leave the experiment area even just for a moment. The tealight candle required for some experiments has to be placed on a fire-resistant surface (such as an old plate). Have a bucket or box with sand ready for extinguishing any fires. If the fire can't be extinguished right away, notify the fire department immediately.
14. When heating test tubes, always hold them with their opening pointed away from you and other people.
15. Immediately wipe up any spilled liquids that evaporate quickly and are highly flammable (e.g. denatured alcohol), and thoroughly rinse out the rag.
16. Any filled container or experimental apparatus that are to remain standing for a longer period of time (e.g., for the precipitation of substances) has to be labeled and stored out of reach of young children and animals.
17. Get any additionally required materials ready before starting an experiment.
18. Handle breakable materials (e.g. the glass test tubes or angled tube) carefully.

Also note the information on the chemical vial labels, the information about "Hazardous substances and mixtures" on p. 7 – 9 as well as the safety and waste disposal instructions for the individual experiments (for example, regarding hazardous gases or how to properly handle the glass tube). If additional products are required, also take note of the warnings on their packaging (e.g. for denatured alcohol).

Safety for Experiments with Batteries

WARNING! Only for use by children aged 11 years and older. Instructions for parents or other supervising adults are included and have to be observed. Keep the packaging and instructions as they contain important information.

- For some experiments, you will need a 9-V type 6LR61 square battery, which could not be included in the kit due to its limited shelf life. Press the battery clip equipped with red and black wires onto the battery.
- Have an adult check your experimental setup before performing the experiment.
- Non-rechargeable batteries are not to be charged. They could explode.
- Rechargeable batteries are only to be charged under adult supervision.
- Rechargeable batteries are to be removed from the toy before being charged.
- Exhausted batteries are to be removed from the toy.
- Dispose of used batteries in accordance with environmental provisions, not in the household trash.
- The supply terminals of the battery clip are not to be short-circuited: Neither the battery wire contacts nor the wires connected to them should touch each other. Make sure there is no unintended short circuit due to conductive metal objects, such as coins or a keychain. A short circuit can cause the wires to overheat and the battery to explode.
- Don't throw batteries into the fire and don't store them near heat sources.
- Avoid deforming the batteries.
- Never perform experiments using household current. You know that you should never insert any objects into the wall socket holes. The high voltage can be extremely dangerous or fatal!
- Don't use any voltage source other than the specified battery, including a power supply unit.
- After you are done experimenting, remove the battery clip from the battery.

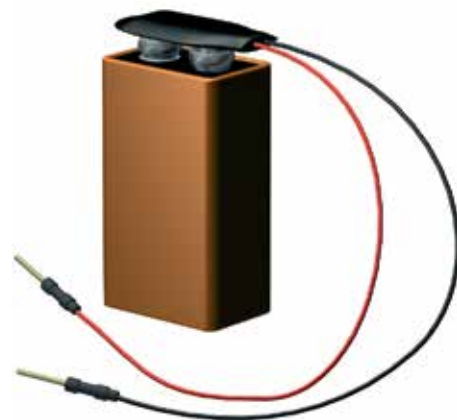

Hazardous Substances and Mixtures (Chemicals)

How they are labeled and how to properly handle them

On the following pages, we provide you with a list of the chemicals contained in this chemistry set as well as the chemicals you will be obtaining in addition that are classified as hazardous substances or hazardous mixtures. For each substance, the list shows **hazard statements** (in blue) and precautionary statements for avoiding the hazards. In the margin, you will find the corresponding **pictograms** and a **signal word** for the scope of the hazard.

The chart on the inside front cover of the manual explains the pictograms that appear in the list of chemical substances on the following pages. The text under each one cites dangers associated with substances that are designated with the pictogram. A substance designated with a pictogram may be associated with one or more of the hazards listed under that pictogram. For example, copper sulfate (exclamation point) is harmful and irritant. You can find out exactly what hazards are associated with a certain substance by referring to the following list.

The pictograms are a component of Regulation (EC) No. 1272/2008, also called the GHS Regulation. GHS stands for Globally Harmonized System, a system whose aim is to achieve a classification and designation of hazardous substances and mixtures that is uniform throughout the world.

Some of the chemicals listed on the following pages only cause limited risks. Therefore they are not labelled with a pictogram or signal word. Nevertheless the given precautionary statements should be observed.



WARNING

Ammonium carbonate/Ammonium bicarbonate (salt of hartshorn) (Not included)
Harmful if swallowed. – Causes serious eye irritation. – May cause respiratory irritation.
Avoid breathing vapors. – Wear eye protection. – IF IN EYES: Rinse cautiously with water for several minutes. Remove contact lenses, if present and easy to do. Continue rinsing. If eye irritation persists: Get medical attention.



WARNING

Ammonium chloride
Harmful if swallowed. – Causes serious eye irritation.
Wash face, hands and any exposed skin thoroughly after handling. – Do not eat, drink or smoke when using this product. – Wear protective gloves/protective clothing/eye protection/face protection. – Wear eye/face protection. – IF IN EYES: Rinse cautiously with water for several minutes. Remove contact lenses, if present and easy to do. Continue rinsing. If eye irritation persists: Get medical advice/attention. – IF SWALLOWED: Call a POISON CENTER or doctor/physician if you feel unwell. Rinse mouth.



DANGER

Calcium hydroxide
Causes skin irritation. – Causes serious eye damage. – May cause respiratory irritation.
Do not breathe dust. – Wear eye protection. – IF ON SKIN: Wash with plenty of soap and water. – IF INHALED: Remove victim to fresh air and keep at rest in a position comfortable for breathing. – IF IN EYES: Rinse cautiously with water for several minutes. Remove contact lenses, if present and easy to do. Continue rinsing. – Get medical advice/attention.
The warnings also apply to its solution in water, called limewater (for preparations, see Experiments 63/64)

Citric acid (Not included)
Not a hazardous substance
Avoid contact with skin and eyes. Avoid formation of dust and aerosols. Further processing of solid materials may result in the formation of combustible dusts.



DANGER

Copper(II) sulfate.
Harmful if swallowed. – Toxic in contact with skin. – Causes skin irritation. – Causes serious eye irritation.
Wash face, hands and any exposed skin thoroughly after handling. – Do not eat, drink or smoke when using this product. – Wear protective gloves/protective clothing/eye protection/face protection. – Specific treatment (See first aid instructions). – IF IN EYES: Rinse cautiously with water for several minutes. Remove contact lenses, if present and easy to do. Continue rinsing. If eye irritation persists: Get medical advice/attention. – IF ON SKIN: Wash with plenty of soap and water. Call a POISON CENTER or doctor/physician if you feel unwell. Remove/Take off immediately all contaminated clothing. Wash contaminated clothing before reuse. If skin irritation occurs: Get medical advice/attention. – IF SWALLOWED: Call a POISON CENTER or doctor/physician if you feel unwell. Rinse mouth.
Very toxic to aquatic life with long lasting effects.
Avoid release to the environment. Comply with the instructions for disposal in the manual. Follow instructions for disposal (A4, A5, p. 124).



DANGER

Denatured alcohol (or methylated spirits; main ingredient ethanol, ethyl alcohol) (Not included)
Highly flammable liquid or vapors.
Keep away from heat/sparks/open flames/hot surfaces. No smoking. – Keep container tightly closed. Storage: Store in a well-ventilated place. Keep cool.
Request to parents: Keep denatured alcohol locked away. Fill burner yourself and decant the amount that will be required for a few experiments into the test tube.

Hydrogen peroxide (3%) (Not included)
Do not get in eyes or on skin.

Iodine solution (maximum of 2.5% Iodine) (Not included)
Do not get in eyes or on skin.
Avoid release to the environment. Follow instructions for disposal (A9, p. 124).

Litmus powder
Not a hazardous substance

Luminol mixture (5% mixture with sodium sulfate)
Not a hazardous substance
Obtain special instructions before use.



DANGER

Magnesium strip
Flammable solids.
Wash face, hands and any exposed skin thoroughly after handling. – Do not eat, drink or smoke when using this product. – Keep away from heat/sparks/open flames/hot surfaces. – No smoking. Ground/bond container and receiving equipment. – Use explosion-proof electrical/ventilating/lighting/equipment. – Wear protective gloves/protective clothing/eye protection/face protection. – IF SWALLOWED: Call a POISON CENTER or doctor/physician if you feel unwell. Rinse mouth. – In case of fire: Use CO₂, dry chemical, or foam for extinction.

Potassium hexacyanoferrate(II)

Not a hazardous substance

Obtain special instructions before use. May be harmful if swallowed. – Harmful to aquatic life with long lasting effects. – May cause slight eye irritation.

Avoid release to the environment. Follow recommendation on p. 83.

Potassium hexacyanoferrate(III)

Causes skin irritation. – Causes serious eye irritation. – May cause respiratory irritation.

Wash face, hands and any exposed skin thoroughly after handling. – Wear protective gloves/protective clothing/eye protection/face protection. – Avoid breathing dust/fume/gas/mist/vapors/ spray. – Use only outdoors or in a well-ventilated area. – Wear eye/face protection. – Specific treatment (See first aid instructions). – IF IN EYES: Rinse cautiously with water for several minutes. Remove contact lenses, if present and easy to do. Continue rinsing. – If eye irritation persists: Get medical advice/attention. – IF ON SKIN: Wash with plenty of soap and water. – If skin irritation occurs: Get medical advice/attention. – Take off contaminated clothing and wash before reuse. – IF INHALED: Remove victim to fresh air and keep at rest in a position comfortable for breathing – Call a POISON CENTER or doctor/physician if you feel unwell.



WARNING

Potassium permanganate preparation (Mixture 1:2 with Sodium sulfate)

Harmful if swallowed. – Causes severe skin burns and eye damage. – May cause fire or explosion; strong oxidizer.

Wash face, hands and any exposed skin thoroughly after handling. – Do not eat, drink or smoke when using this product. – Do not breathe dust/fume/gas/mist/vapors/spray. – Wear protective gloves/protective clothing/eye protection/face protection. – Keep away from heat/sparks/open flames/hot surfaces. – No smoking. – Keep/Store away from clothing/combustible materials. – Take any precaution to avoid mixing with combustibles. – Wear fire/ flame resistant/retardant clothing. – Immediately call a POISON CENTER or doctor/physician. – Specific treatment (See first aid instructions). – IF IN EYES: Rinse cautiously with water for several minutes. Remove contact lenses, if present and easy to do. Continue rinsing. Immediately call a POISON CENTER or doctor/physician. – Wash contaminated clothing before reuse. – IF ON CLOTHING: Rinse immediately contaminated clothing and skin with plenty of water before removing clothes. Rise skin with water/shower. – IF INHALED: Remove victim to fresh air and keep at rest in a position comfortable for breathing. Immediately call a POISON CENTER or doctor/physician. – IF SWALLOWED: Call a POISON CENTER or doctor/physician if you feel unwell. Rinse mouth. Do NOT induce vomiting. – In case of major fire and large quantities: Evacuate area. Fight fire remotely due to the risk of explosion. – In case of fire: Use CO₂, dry chemical, or foam for extinction.

Very toxic to aquatic life with long lasting effects.

Avoid release to the environment. Comply with the instructions for disposal in the manual. Follow instructions for disposal (A7, A8, p. 124).



DANGER

Sodium carbonate

Harmful if inhaled. – Causes serious eye irritation.

Avoid breathing dust/fume/gas/mist/vapors/spray. – Use only outdoors or in a well-ventilated area. – IF IN EYES: Rinse cautiously with water for several minutes. Remove contact lenses, if present and easy to do. Continue rinsing. If eye irritation persists: Get medical advice/attention. – IF INHALED: Remove victim to fresh air and keep at rest in a position comfortable for breathing. Call a POISON CENTER or doctor/physician if you feel unwell.



WARNING

Sodium hydrogen sulfate

Causes serious eye irritation.

Wear protective gloves/protective clothing/eye protection/face protection. – IF IN EYES: Rinse cautiously with water for several minutes. Remove contact lenses, if present and easy to do. Continue rinsing. If eye irritation persists: Get medical advice/attention.



DANGER

Sulfur

Causes skin irritation. – Flammable solids.

Wash face, hands and any exposed skin thoroughly after handling. – Wear protective gloves/protective clothing/eye protection/face protection. – Keep away from heat/sparks/open flames/hot surfaces. – No smoking. – Ground/bond container and receiving equipment. – Use explosion-proof electrical/ventilating/lighting/equipment. – Specific treatment (See first aid instructions). – IF ON SKIN: Wash with plenty of soap and water. – If skin irritation occurs: Get medical advice/attention. – Take off contaminated clothing and wash before reuse. – In case of fire: Use CO₂, dry chemical, or foam for extinction.



WARNING

Warning! The following applies to all chemicals:

Store locked up. Keep out of reach of children. This applies to all children except for the experimenting child who is being instructed and supervised by an adult.

Also follow this precautionary statement:

IF SWALLOWED: Get immediate medical advice/attention and have product container or label of chemical substance at hand.

For the sake of environmental protection: **Dispose of contents/ containers (of no-longer-needed chemicals) to a hazardous waste disposal location.**



For information on the protective equipment, see "Workspace and Equipment" on p. 11.

1

Chemistry Is Everywhere



View into a modern chemistry lab (photo: BASF)

For a lot of people, chemistry remains a mysterious science, something they assume is difficult to understand, dangerous, and irrelevant to their daily lives. Maybe they didn't pay attention in school, or their image of chemistry comes from old books or movies where seemingly mysterious things happened. For example, you might have seen a movie that depicts an old, wiry haired professor in his laboratory, surrounded by complicated pieces of equipment in which things are brewing, bubbling, and hissing. The professor stares spellbound at a flask into which a red liquid drips, his latest discovery. But maybe the professor made a mistake with the ingredients, or someone who wishes him harm meddled with them on the sly — resulting in a deafening explosion or some other disaster! The lab is destroyed, and the professor can consider himself lucky if he gets away with the fright of his life and a few scratches.

So it's no wonder that a lot of people still think that chemistry is what explodes and stinks. Now, it doesn't always smell like roses in chemistry labs and factories, but explosions happen only rarely. Outside in the streets, on the other hand, things are exploding millions of times every second — in automobile engines. Those explosions are chemistry! But chemistry is also at work in all sorts of much quieter processes — when candles burn, iron rusts, or green plants produce sugar from a gas that has made its reputation as a climate changer. All biological processes taking place in people, animals, and plants can be studied and explained with chemistry.

You don't need a lab like the old professor's if you want to understand all these chemical processes. This experiment kit will give you an easy entry into chemistry, and the instruction manual will be a reliable guide on your voyage of discovery through the realm of chemicals. When chemists refer to chemicals, they can be talking about any and every known bit of matter — everything is made of chemicals.



Question 1. When you think of chemicals, what comes to mind? Name some of the chemical substances you can think of.*



Nature and chemistry — not opposites at all. Research into natural materials and processes is also part of a chemist's work.

You will learn to see everyday materials from a completely new perspective: ordinary table salt, for example, which contains a poisonous gas, or the already-mentioned climate-altering gas that also happens to be responsible for the fizz in a soda bottle. At the same time, you will become familiar with the chemist's work techniques: filtering, distilling, and heating things in test tubes. And you will learn about important basic concepts of chemistry: elements and compounds, atoms and molecules, ions and pH values. All of this represents knowledge that you can later build on in school or by experimenting with a larger chemistry kit.

In short, chemistry will not be a mysterious science for you, or a foreign topic that you only see depicted in movies and books. You will be able to find your way around better than a lot of other people in an area of knowledge that is very important in today's world. Have we made you curious? So now, it's time to start.

* You will find answers to the questions beginning on p. 125.

2

Workspace and Equipment

You won't be able to do too much harm with this chemistry kit, but it would still be good to have a work area that can handle a few spills. A sturdy old table with a washable surface, capable of handling heat and a few stains, is ideal. The kitchen, or any place with food nearby, is not a suitable place for chemistry experiments. It is important for your work area to be well lit and easily ventilated. Some of the experiments will have to be performed next to an open window or outside (on a balcony, for example). You will need sufficient space for your experiments.

The work area should be free from all unnecessary objects. Tablecloths, curtains, and other flammable materials have no place in the immediate vicinity of your work area. Also, be careful not to let loose sleeves, scarves, or handkerchiefs fall into the experimental apparatus or into the alcohol burner flame. If you have long hair, tie it back with a hair tie.

The most important chemical in the lab is water. You will need it not only to clean things, you will also be using it to carry out interesting experiments. If you don't have a sink nearby, keep a supply bottle on hand, such as a carefully rinsed dishwashing liquid bottle filled with water. Liquid waste that can go down the drain — directly or after appropriate treatment — can be collected in a plastic bucket filled halfway with water and labeled "chemical waste," which you can empty immediately following your experiments and then rinse out several times with water.

Dispose of the waste as described in Chapter 19. At the end of the experiments, you will find comments written in green about which of the disposal methods — A1 through A9 — should be used. To wipe up spills, use paper towels or a rag, which you should rinse thoroughly after use.

The most important component in your protective equipment is the pair of **safety glasses** (part no. 1). An old smock or oversized shirt will serve as protective clothing. Gloves with a smooth surface (such as tight fitting rubber gloves) are suitable for use as safety gloves.

You should always keep the following frequently-needed materials at your workplace: pens and paper, lighter, matches, aluminum foil (roll), ruler, scissors, metal tweezers, flat-nosed pliers, old spoon, old knife, old saucer. If other people are going to have access to your work area, you will have to keep all your experiment equipment and chemicals stored out of the reach of young children and pets, ideally locked away in a cupboard.



"Time to do some research!"

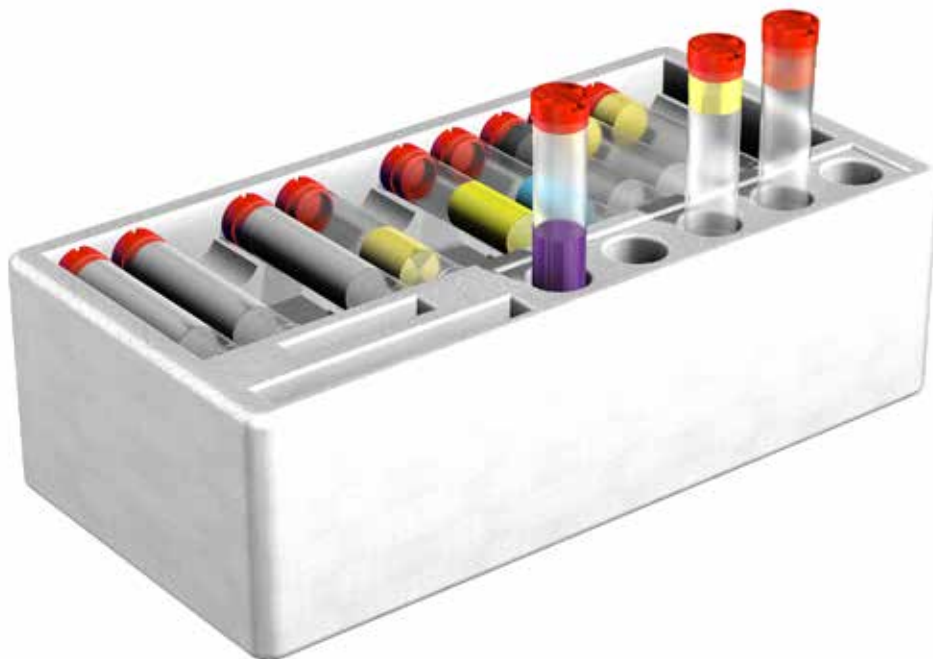

CHEM C2000's polystyrene foam insert should be split with a sharp knife by an adult (!). It has one small storage area intended for the small chemical vials, and a larger one for the other equipment. When performing experiments that need a lot of space, you can set aside one of the pieces, but only if you put it somewhere that is inaccessible to young children.

The basic equipment

The chemist's most indispensable tool is the **test tube** (part no. 17). You can mix liquid and solid substances in it, and you can also heat them in it. To clean the test tubes, use the **test tube brush** (part no. 24). But don't push too hard, or you will break the bottom of the test tube. Test tubes are made of fairly thin glass, because thicker glass would break when heated. It is easiest to clean them under running water.

The **test tube stand** (part no. 18) performs a lot of different duties. The smaller holes are for holding filled test tubes, while the larger holes hold freshly-washed test tubes with their opening pointed down so the water can drip out. The **chemical vials** (parts no. 29 – 40) have two chambers, a large one for larger quantities and a small one for chemicals that you only need to use in small amounts. The quantities inside them correspond to what you will need as well as requirements that apply to chemistry sets. The uniform size of the vials is determined by the size of their label, which has information prescribed by law.

The illustration shows how to open the safety closures using the **lid opener** (part no. 27) provided with the kit. Sometimes when you open them, a little of the chemical gets stuck to the lid and can fall onto your hand or the work surface. You can prevent that by banging the vial a few times on the work surface before opening it. Place open vials in the large holes of the test tube stand or in the recesses of the polystyrene chemical storage unit. After you have taken what you need from the vial, close it again immediately. There is an explanation on p. 36 of the way the **safety cap** (part no. 15) works on the **litmus solution vial** (part no. 28).

Opening and closing the safety closures sometimes requires quite a bit of force. If necessary, have an adult help you.

You can use the **double-headed measuring spoon** (part no. 26) to take chemicals from the containers and to measure the amounts. When the instructions refer to "1 spoonful" or "1 large spoonful," that means one level scoop from the larger end, and "1 small spoonful" means a level scoop from the small end. "One spoon tip" means about half a scoop with the smaller end. You must wash the spoon (rinse and dry it) after each use, since otherwise you will introduce trace amounts of the chemicals into other vials.

When you want to add liquids drop by drop, the **dropper pipette** (part no. 19) will come in handy. The illustration on the left shows how to use it. Squeeze the upper part of the pipette between your thumb and forefinger and dip the end into the liquid. As soon as you release pressure on the bulb, the liquid rises into the pipe. Then, you can release individual drops one by one by applying gentle pressure on the bulb. After use, clean the pipette by filling it repeatedly with water, shaking, and emptying.

For measuring larger quantities of liquids, use the **graduated beakers with lids** (parts no. 3/4).

You will need the **funnel** (part no. 5) mostly for filtering. In Experiment 15, you will find a description of how to place the circular filter papers (white coffee filters from the supermarket) into the funnel. The funnel is usually placed over a test tube. If you want to filter something into a graduated beaker or another larger container, set a cardboard lid onto the container with an opening to hold the funnel.

Your heating source — the alcohol burner

You often have to heat materials in chemistry experiments. To do that, you will be using the alcohol burner, composed of the **burner base** (part no. 6), the **insulating piece** (part no. 7), the **wick holder** (part no. 9) with **aluminum disk** (part no. 8), the **wick** (part no. 10), and the **burner cap** (part no. 11).



The test tube stand

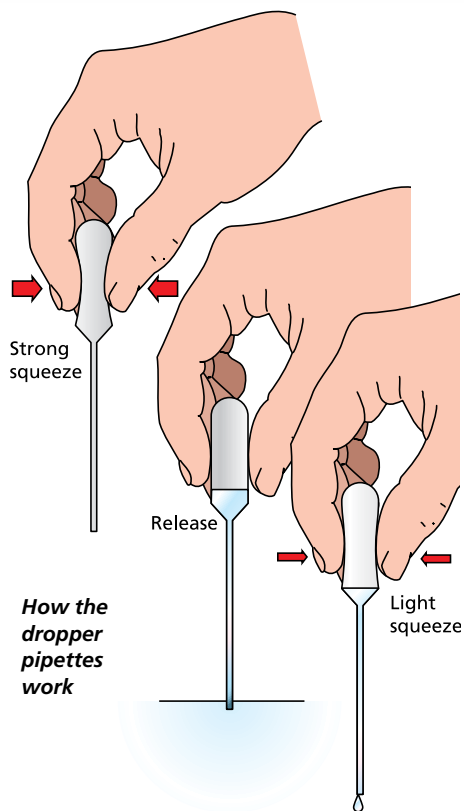

How the dropper pipettes work

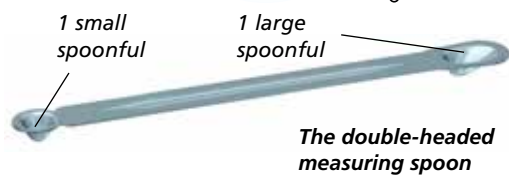

The double-headed measuring spoon



Filtering into a larger container



The illustration shows how the wick, wick holder, and insulating piece fit together. To fill the denatured alcohol into the burner, you will be using the funnel. Be sure to observe the maximum fill level marked on the burner base.

For the denatured alcohol (also called methylated spirits or rubbing alcohol), use a solution of greater than or equal to **70% ethyl alcohol** found in most drugstores (the other 30% is water). This burns much cleaner and with less soot than solutions of isopropyl alcohol, which are commonly sold in concentrations above 90%.



For **denatured alcohol**, note the "Hazardous substances and mixtures" information starting on p. 7. The burner should **only be filled by an adult**, who must also keep the denatured alcohol bottle under lock and key away from the experiment area. Do not fill the burner while it is hot, the wick is still glowing, or other flames are burning nearby. Close the alcohol bottle immediately after use. Wipe up any spilled alcohol right away (let the rag dry out in the open).



Now, push the prepared wick holder with the wick into the burner opening. The wick should not stick out so far that the burner cannot be tightly sealed with the burner cap (or the alcohol will evaporate). Once the alcohol has risen up the burner wick, you can light the burner. If you want to extinguish the flame, simply lower the burner cap over it. Be careful not to let the burner burn itself dry, or the insulating piece could get damaged. Notify your adult assistant well before you need help refilling it.

Your first task will be to boil some water. An adult must help you. Boiling water safely and so nothing splashes into your eyes is not as easy as it might seem. So don't forget: Always wear your safety glasses!

EXPERIMENT 01

Fill a test tube with 3 cm of water. (Test tube measuring information is on the next page.) To keep from burning your fingers when heating it, clip it in the **wooden test tube holder** (part no. 25). Be sure that the test tube is completely dry on the outside. Hold the test tube at a tilt above the flame and rock it gently back and forth without letting the holder get into the flame, as shown in the illustration. Be careful not to let the test tube opening point at yourself or another person. Why? A bubble of steam will often form on the bottom of the test tube, which can make the water shoot out.

EXPERIMENT 02

You can pretty much prevent spurts and spills by using the **boiling rod** (part no. 23). Lower it into the liquid to be heated with the small hollow space pointing down. Soon, bubbles of gas will start rising up and the jiggling and spraying will end.

If you have hot test tubes that you have used to heat a liquid, you can set them directly in the test tube stand. But if you used them to heat a solid substance, they should not be set directly in the test tube stand. They might be several hundred degrees Celsius ($^{\circ}\text{C}$), and they would damage your test tube stand. So instead, insert the test tube holder with the hot test tube into a vertical or angled opening of the test tube stand. You should never try to cool off hot test tubes with water. They would break.

Working with glass tubes

It's not as easy as you might guess to insert the **angled tube** (part no. 22) and the **pointed glass tube** (part no. 21) into the holes of the **stoppers** (parts no. 13 and 14), or to pull them back out again. Ask an adult to help you with it.



Broken glass tubes can cause unpleasant cuts. Do not force the glass tube into the holes! In case of injury: **First Aid 7** (inside front cover).



Read and follow the advice provided on the next page.

Glass tubes should be twisted into the stopper, not shoved.

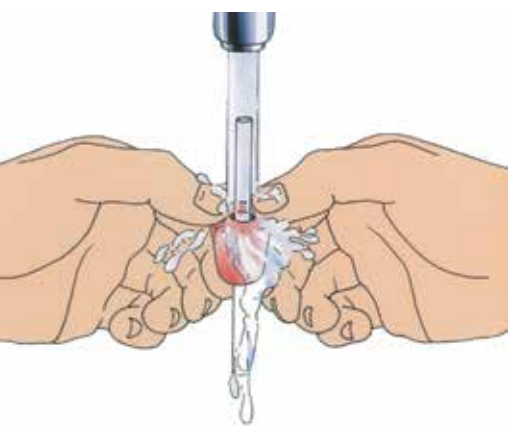
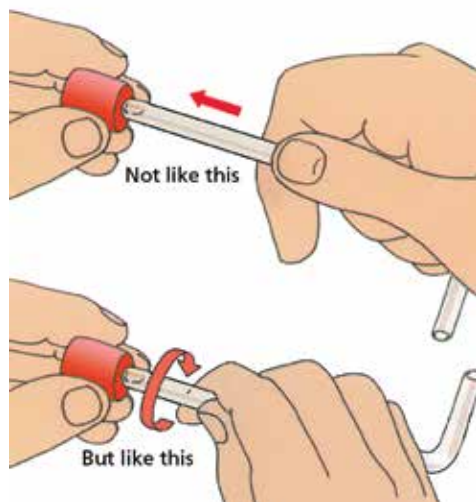

How to make it easier to release a glass tube from the rubber stopper.

Don't just shove the glass tube into the stopper. You must gently twist it in. You will have to hold the glass tube as close as possible to the end that is to be inserted, as shown in the illustration. Always be sure to moisten the glass tube and stopper opening with plenty of water before insertion. You can give yourself an extra measure of protection by holding the tube with a thick cloth.

You will often encounter difficulties when you try to pull a glass tube out of a stopper too. Try the following trick: Loosen the rubber by pulling it away from the tube on both sides while letting a thin stream of water flow into the resulting gap. Repeat the procedure on the other side of the stopper. Now grab the glass tube just above the stopper and pull it out of the opening while twisting steadily. Please be sure to follow these safety measures.

The test tube as "measuring device"

With the small graduated beakers, you will be able to measure fluids accurately down to about 1 ml. But most of the experiments don't require that much accuracy. When it says, "Add 5 ml of the solution to the test tube...", it would still be okay to add 4 or 6 ml, although not 1 or 10. An experienced chemist knows the level that 3, 5, or 10 ml would rise to in the test tube. You will also know this before long.

The illustrated template to the right will make it easier for you to estimate quantities at first. If you like, you can also use the template to "calibrate" a test tube (use a permanent marking pen).

Note: 1 ml — the abbreviation for milliliter — is one thousandth of a liter (L), and corresponds to a cubic centimeter, abbreviated cm^3 , for solid substances.

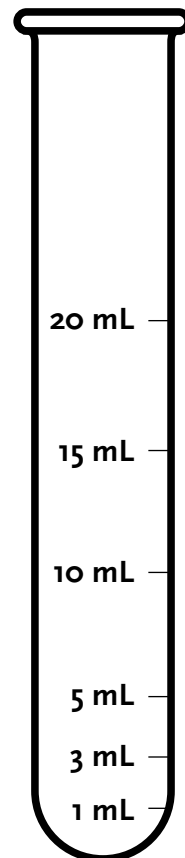

Additionally required materials

Containers that cost nothing and would otherwise go in the trash:

- two or three transparent glass jelly jars (250 and 450 g) with lids, cleaned and with their labels removed; called **screw-top jars** (or sometimes just jars) in the experiments
- plastic tub that at one time contained ice cream or hamburger meat, for example; called a **basin** in the experiments
- two small, clean bottles for storing prepared solutions, such as limewater and potassium hexacyanoferrate(II) solution
- a larger container such as a preserving jar (1 or 1.5 L)

Items that are found in the household or easy to get from the supermarket or specialty store:

- denatured alcohol (a solution of greater than or equal to 70% ethyl alcohol), distilled white vinegar (5% acidity), distilled (demineralized) water
- aluminum foil, paper towels, white coffee filters (flat or cone), wooden splints or skewers, tealight candles, steel wool
- iron nail (4 – 5 cm long), 9-volt square battery, permanent felt-tip marker, fine artist's brush or fountain pen with steel nib
- baking soda, citric acid, plaster (gypsum), ammonium carbonate

From the drug store:

- hydrogen peroxide, 100 ml, 3% solution (bottle with safety cap)
- iodine solution (recommended solution: Lugol's iodine solution, 2.5% (10 ml in a child-resistant bottle): Iodine 2.5% (m/V) in a 2.5% (m/V) aqueous solution of potassium iodide, or iodine 0.025 g/ml mass concentration in an aqueous solution of 0.025 g/ml mass concentration of potassium iodide)
- ascorbic acid (vitamin C powder without additives)

Request to parents: Keep larger quantities of additionally required materials locked away, and only provide the experimenting child with the required amount for the experiments to be performed.



Material that would otherwise land in the trash.

Cleaning the lab equipment

If an experiment doesn't go off well, it may be because you used a test tube or jar that wasn't sufficiently clean. So you should start by getting used to cleaning all your containers immediately after completing your experiments.

In most cases, cold water and the test tube brush will be all you need to clean your equipment. If it doesn't work with those, try it with hot water and a little dishwashing liquid. That will remove all fatty impurities. Be sure to rinse thoroughly afterwards.

With some experiments, there will be residues that you can easily remove by following the instructions below:



For chemicals used for cleaning purposes, note the safety information starting on p. 7!

Prussian blue. A blue coloration left behind after tests for iron with potassium hexacyanoferrate(II) is easily dissolved in sodium carbonate solution.

Brown **manganese oxide** residues are left behind after experimenting with potassium permanganate. You can remove them with hydrogen peroxide solution that has first been acidified with a little sodium hydrogen sulfate.

Calcium residues. The white coatings that form when working with limewater, for example, disappear when you add vinegar. Let the vinegar work a little while, swirl the test tube, and rinse thoroughly with water.

Copper(I) oxide. When testing for glucose, you will often get a reddish coating of copper(I) oxide, which can be easily dissolved in a little sodium hydrogen sulfate solution.

Soot-containing coatings, which can form on the outside of test tubes, for example, when you heat them over the burner flame, are easy to remove: Rub a little scouring powder on the area you want to clean and rinse with water.

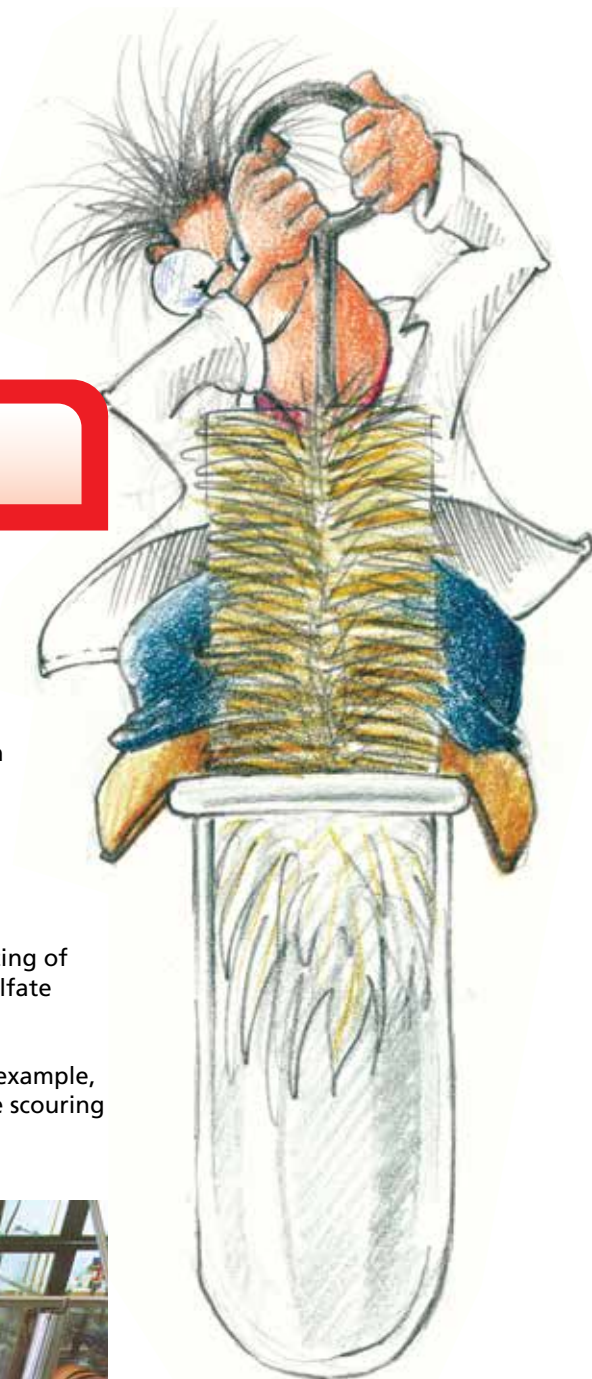

View into a modern industrial lab (photo: BASF)

3

Without Water There Is No Life — And No Chemistry

Disappearing materials

Real magicians know the trick of making themselves invisible. Simple materials like sugar and salt can do that too.

EXPERIMENT 03

Fill two test tubes halfway with water and add 2 spoonfuls of sugar to one of them. Shake the test tube with the sugar until it is completely dissolved. Can you see any difference between the contents of the two test tubes?

What has been created here is a solution. Solutions are homogeneous (uniform) mixtures in which the components can no longer be differentiated. [A1](#)

(Waste disposal methods A1–A9 are described beginning on page 123.)



For **sodium carbonate**, note the “Hazardous substances and mixtures” information starting on p. 7.

EXPERIMENT 04

Ask an adult to help you with this experiment. Fill one test tube halfway with water that is as hot as possible, and a second halfway with cold water. To each test tube, add 1 spoonful sodium carbonate and observe in which one the substance dissolves faster.

A reason why chemists heat things is the fact that most reactions happen faster at higher temperatures. The particles contained in the solution — in our case, water and sodium carbonate particles — collide with greater energy, which helps them mix together. [A1](#)

EXPERIMENT 05

Add two spoonfuls of sugar to each of two test tubes filled halfway with cold water. Thoroughly shake one of the test tubes for 10 seconds. Can you notice any difference in the speed the sugar dissolves in the two test tubes?



Water

PROFILE

There is no life without water. You know how distressing it can be to be thirsty, and you probably also know that humans can, under certain conditions, go for months without eating, but without water they will die of thirst after just a few days. What applies to humans also applies to all living things. Plants and animals need water to dissolve and transport the materials they produce to maintain the biochemical processes that keep them alive.

In the natural landscape, water has left behind some impressive evidence of its

presence, as it continues to do to this day. It has dug deep chasms in Earth’s surface. It helps to erode mountain ranges and to carry off the eroded material. Where it plunges downward, it can drive turbines and contribute to the production of clean energy.

Unfortunately, people don’t treat this valuable commodity with as much care as it deserves. Industry, agriculture, and private households pollute surface water, or the water in rivers and lakes. Since the groundwater level is already dropping due to other environmental sins — such as deforestation — we have to rely increasingly on surface water for our drinking water supply, which in turn requires costly precautions.

The following experiments will show you

how essential water is as a solvent for chemists. You will also learn how you can contribute to the proper disposal of the wastes that are produced in the process.





When you pour sugar solution into water, it forms streaks. On the left, you see water before the sugar has been poured in, while on the right you see water after pouring, with a temporarily cloudy appearance.

A concentrated sugar solution has formed above the sediment in the unshaken test tube, which only absorbs the undissolved sugar very slowly. When you shake the test tube, new parts of the water keep coming into contact with the still-undissolved sugar, which accelerates the dissolving process. **A1**



Question 2. How can you achieve the same effect in everyday life? It's not always convenient to shake something.

EXPERIMENT 06

Pour a sugar solution (3 spoonfuls of sugar in a test tube half-filled with water) into some clear water in a screw-top jar. If you look through the jar from the side, you will see what look like transparent streaks. **A1**

When you pour in the sugar solution, it temporarily creates areas of different densities, which refract light in different ways. By density, we mean the mass (in grams) per unit of space (in cubic centimeters), abbreviated g/cm^3 .



For **ammonium chloride** and **copper sulfate**, note the "Hazardous substances and mixtures" information starting on p. 7.

EXPERIMENT 07

Add 3 cm of water to each of two test tubes, along with 1 spoonful of ammonium chloride to one test tube and 1 spoonful of copper sulfate to the other. Close each test tube with a rubber stopper and shake each one for 10 seconds. **A1, A4**

You will see that some substances dissolve more easily than others.

Saturated and unsaturated solutions

EXPERIMENT 08

Add 3 cm of water to a test tube, and gradually add table salt to it in small portions. Each time you add some salt, shake thoroughly. Continue adding until nothing more will dissolve in it, which you can tell by the formation of a sediment in the test tube that won't disappear. **A1**

You have made a saturated solution. The solution is "full," meaning it can't dissolve any more salt. Since you used cold water as a solvent, this is a cold-saturated solution.

potassium hexes...? potato acid and ... hexa ... pots and fares and hexes?



Basic Knowledge

Don't be afraid of technical jargon

Ammonium chloride and copper sulfate, ouch! Or maybe you have already discovered the vial of potassium hexacyanoferrate(II). Isn't there an easier way? A lot of the substances with names like this also have a common name. For example, potassium hexacyanoferrate(II) is also known as yellow prussiate of potash. But it's a good idea to start by learning the precise scientific name. Anyway, yellow prussiate of potash is just as much a "foreign language" to you as potassium hexacyanoferrate(II). At first, you can merely note the scientific name, and later — in school or when you're working with a larger chemistry set — you can also understand it. The scientific names have the advantage of enabling a practiced chemist to immediately recognize how the material is composed. Folk names are more likely to say something about where it comes from or how it's made. The name yellow prussiate, for example, comes from the fact that it is similar to a chemical discovered in the early 18th century in a region of Europe that used to be called Prussia.



After 20 cubes of sugar, the sugar bowl is empty and the coffee is “stuffed” with sugar.



Question 3. How would you explain the term “unsaturated solution”?

EXPERIMENT 09

Repeat the previous experiment with 1–2 cm of water and ammonium chloride in the test tube. This time it takes quite a bit longer for a sediment to form, that is, until you get a cold-saturated ammonium chloride solution. Heat the test tube over the alcohol burner flame (use the boiling rod!). Now the sediment dissolves as well. The hot solution is no longer saturated (retain it for Experiment 10).

In theory, you could keep adding ammonium chloride until you get a sediment that won’t dissolve — that is, until you get a saturated solution at the higher temperature. Due to your small supply of ammonium chloride, though, you shouldn’t do that.

EXPERIMENT 10

Cool the heated solution from Experiment 9 under cold running water. Suddenly, you see white crystals. The ammonium chloride is back! **A1**

If you heat a saturated solution, it gets hungry again: it can swallow more of the substance. If you then cool it back down to the starting temperature, the additionally swallowed substance crystallizes out again.

Geometry of crystals

EXPERIMENT 11

Prepare a saturated table salt solution and pour 2 cm of it into a test tube. Heat the test tube, with the boiling rod inserted, for a few minutes and then pour the contents into a shallow pan. Set the pan in a place where young children can’t get to it and tape a note to it: table salt. After one or two days, take a closer look at the pan. The liquid has evaporated, leaving behind a lot of small (and some larger) crystals. If you have a simple microscope or a good magnifying glass available, you will be able to determine that the crystals are cube-shaped.

If you draw water out of a solution — by evaporation, say — the dissolved particles resolidify into crystals. The shape of the crystal depends on the organization of the smallest particles inside it. With table salt — or sodium chloride in technical terms — you get cube-shaped crystals. **A1**



Sodium chloride (table salt) crystals.

Crystals seen through the microscope (some in polarized light):

- A Beet sugar crystals
- B Vitamin C crystals
- C Crystals in brown onion skin
- D Table salt crystals
- E Aspirin crystals

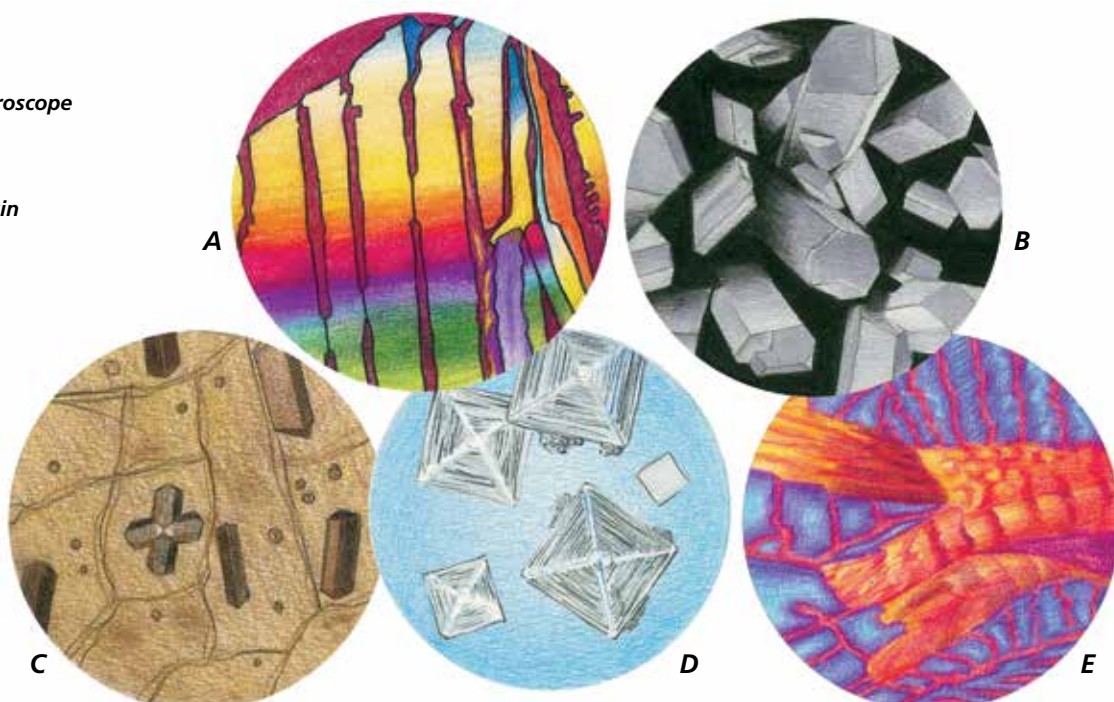



For **copper sulfate**, note the “Hazardous substances and mixtures” information starting on p. 7.

EXPERIMENT 12

In a test tube, dissolve a spoonful of copper sulfate in 2 cm of water, and proceed as in the previous experiment. Pour the solution into a graduated beaker. The copper sulfate will also crystallize out after it has sat a while. When viewed from above, the crystals have the shape of small parallelograms. That, at least, is what mathematicians call sharp-angled squares with two sets of parallel sides. Return the dry crystals to the chemical vial — you can save them for further experiments.

Note for crystal fans: The table salt or rock salt crystals belong to the class of regular crystals, while copper sulfate crystals belong to the triclinic crystal system.



Copper sulfate crystals on barite

Separating materials

Water is often separated from other materials in order to clean it, or rid it of contaminants or pollutants (such as when making drinking water). But water can also be an important aid when separating other materials.

EXPERIMENT 13

Add 3–4 spoonfuls of sand to a test tube and fill the test tube halfway with water. Shake thoroughly and set the test tube in the test tube stand. What do you observe?

Right! The sand settles to the bottom of the test tube, with a clear liquid above it: water.

EXPERIMENT 14

You can separate water and sand from each other fairly effectively by carefully pouring off the water into another container. Toward the end, when you have to tilt the test tube more, a little sand usually gets pulled along. Still, the separation works pretty well. This process is known as decanting. The term is often used when pouring wine off of its sediment. [A1](#), [A3](#)

EXPERIMENT 15

Additional material: White, round coffee filter

You can achieve an even better separation through filtration. You can use white coffee filters for this. There are round filters and other filters out of which you can cut round filters. Fold a circle of filter paper along the red folding lines, as shown in the illustration. You will get a sort of “cone” consisting of one layer of filter paper on one side and three layers on the other side. Set the filter cone in the funnel and moisten it with a little water, so the filter paper sticks to the funnel. Set the funnel in a test tube and pour the sand-water mixture onto the filter. The clear liquid dripping into the test tube — in this case, water — is known as a filtrate. The sand remains behind on the filter. [A1](#), [A3](#)

Sand consists of little crystals of quartz. They are insoluble in water and relatively heavy, so they will sink to the bottom if placed in water. The grains of quartz are also too big to slip through the pores of the filter paper, which works like a super-fine sieve.



How to fold a piece of filter paper and insert it in the funnel



Evaporated table salt

EXPERIMENT 16

Dissolve 2 spoonfuls of table salt in 5 cm of water and filter the solution.

EXPERIMENT 17

Place 1–2 cm of the filtrate from Experiment 16 in a test tube and set the boiling rod in the test tube. Now clamp the test tube in the test tube holder and rock it carefully back and forth in the burner flame. The water will gradually evaporate. When there are just a few drops of liquid left in the test tube, remove the boiling rod and continue heating. A fine white crust will be left behind: table salt. The operation just described is known as **evaporation**.



Question 4. What happened to the table salt in the filtration process?

The smallest particles of the table salt and a lot of other substances are so small that even the fine pores of the filter paper can't hold them back. Substances like this cannot be separated from water by filtration.

The unequal solubility of table salt and sand allows the two substances to be separated — with the help of water.

EXPERIMENT 18

Add 3 spoonfuls of sand and 3 spoonfuls of table salt to a test tube, fill halfway with water, shake well, and filter.

The sand remains behind on the filter, while the salt is in the filtrate. To recover the salt as a solid substance, you will have to evaporate the filtrate as in Experiment 17.



In industrial production, solid salts are prepared in large crystallizers (photo: Lurgi).



Chemically pure water

In Experiments 11 and 17, you recovered table salt from salt water by a process of evaporation. But what if it's the water you want instead of the salt? How can you rid water of salt? You can't do it by filtering, as you already know. You have to use a different method.

EXPERIMENT 19

Assemble the experimental setup shown in the illustration. To start, carefully twist the short arm of the angled tube into the hole in the rubber stopper.



Be careful when twisting the angled tube into the stopper! Note the information on pages 13/14. In case of injury: **First Aid 7** (inside front cover).



A preliminary water analysis can be performed "on site" with a portable water lab (photo: Macherey-Nagel).

Fill 2 cm of table salt solution into the tilted test tube and insert the prepared stopper. The long arm of the angled tube will dip into an empty, dry test tube sitting in a jar of cold water for cooling purposes. Slowly move the alcohol burner to and fro beneath the test tube filled with salt water. You can keep the salt water from boiling too strongly and getting into the tube by pulling away the burner when necessary. After a little while, steam will start to escape through the angled tube. At the same time, a clear liquid will begin dripping into the cooled test tube.

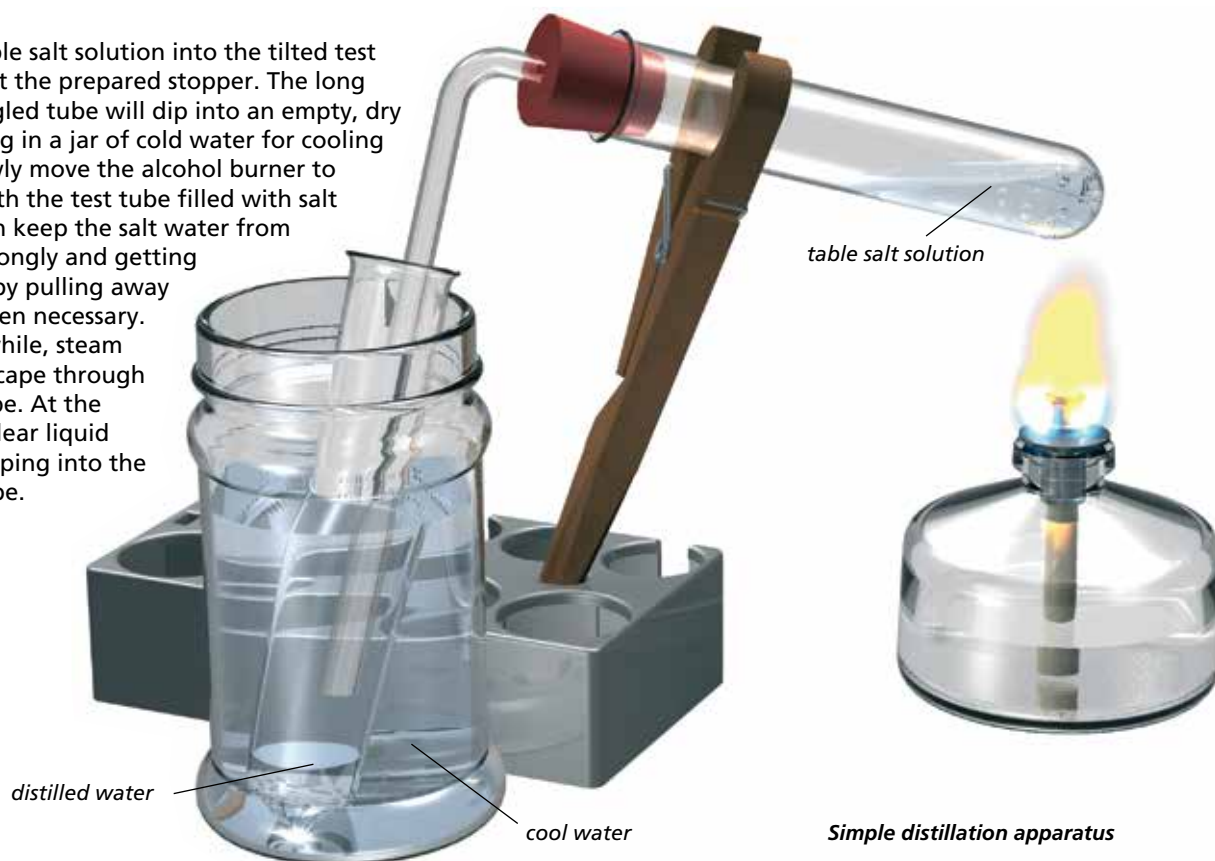

Simple distillation apparatus



Caution! Before putting out the flame or moving the burner away, you will have to be sure that the angled tube isn't dipping into the recovered water (disassemble the apparatus). This would result in the captured liquid rising back up into the still-hot test tube, which could damage it.

When you heat the salt solution, a portion of the water evaporates. The water vapor flows through the angled tube into the cooled test tube, where it changes back into liquid water. The salt, meanwhile, remains behind in the test tube. The solution's **concentration**, its table salt content, has increased — since, after all, the same amount of salt is contained in less water. **A1**

This process is known as **distillation** (Latin *destillare* = to drip down). The water obtained in this manner is called **distilled water**. By the way, any soup pot has a distillation process taking place in it. Try tasting the no-longer-hot (!) drops suspended from the pot's lid. They taste flavorless, even if the soup is salty. That water hanging from the lid of the pot is distilled water.



Fine-cleaning of drinking water with activated charcoal (Lurgi factory photo)



Water in solid and liquid form

Historical device for electrolyzing water
From: *Stöckhardt, The School of Chemistry (1863)*

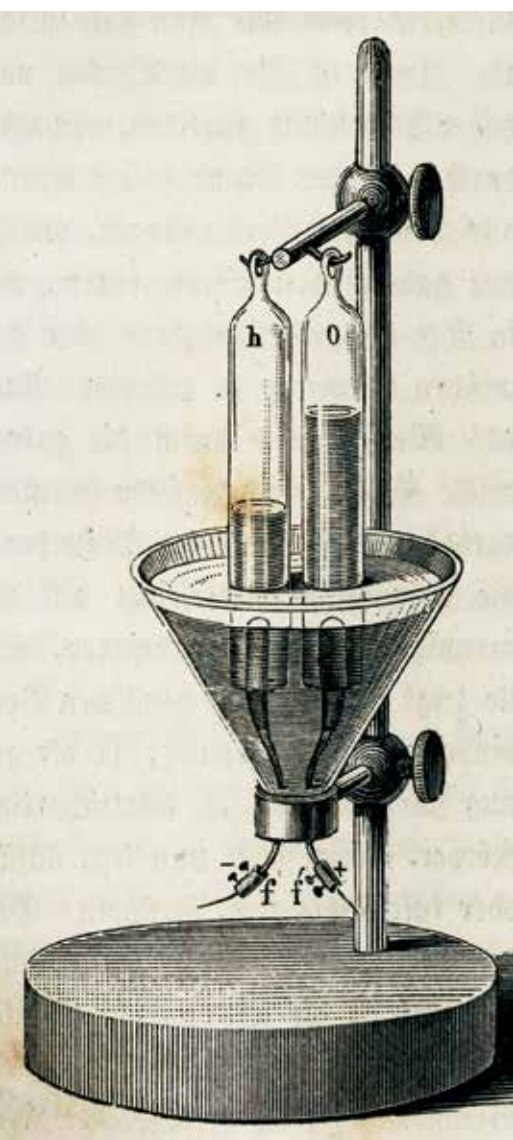

For **copper sulfate**, note the “Hazardous substances and mixtures” information starting on p. 7.

EXPERIMENT 20

Of course, you can also use this method to rid water of other additives. Repeat the experiment with copper sulfate solution (dissolve 1 spoonful of copper sulfate in 5 cm water). The liquid dripping into the cooled test tube — the distillate — is completely colorless. **A4**

EXPERIMENT 21

Even more dramatic is a distillate from a downright filthy broth that you brew together from water, ink, and dirt. Even in this case, you will still get a colorless distillate: distilled water. **A1**

What is water actually made of?

“Funny question!” you might say. Water is water. Anyone can see that it’s not made of other things. Let’s let an experiment decide the matter.

EXPERIMENT 22

Additional material: Two uncoated iron nails, baking soda, 9-volt square battery

Add two spoonfuls of baking soda (chemically: sodium hydrogen carbonate, or sodium bicarbonate) to a graduated beaker filled halfway with water, put on the lid, and shake. Now, using the yellow wire, connect the nails to the battery clip terminals. Immerse the ends of the nails in the solution in the graduated beaker — but don’t let them touch each other.

If you watch closely, you can see that bubbles of gas are rising from both nails. **A1**

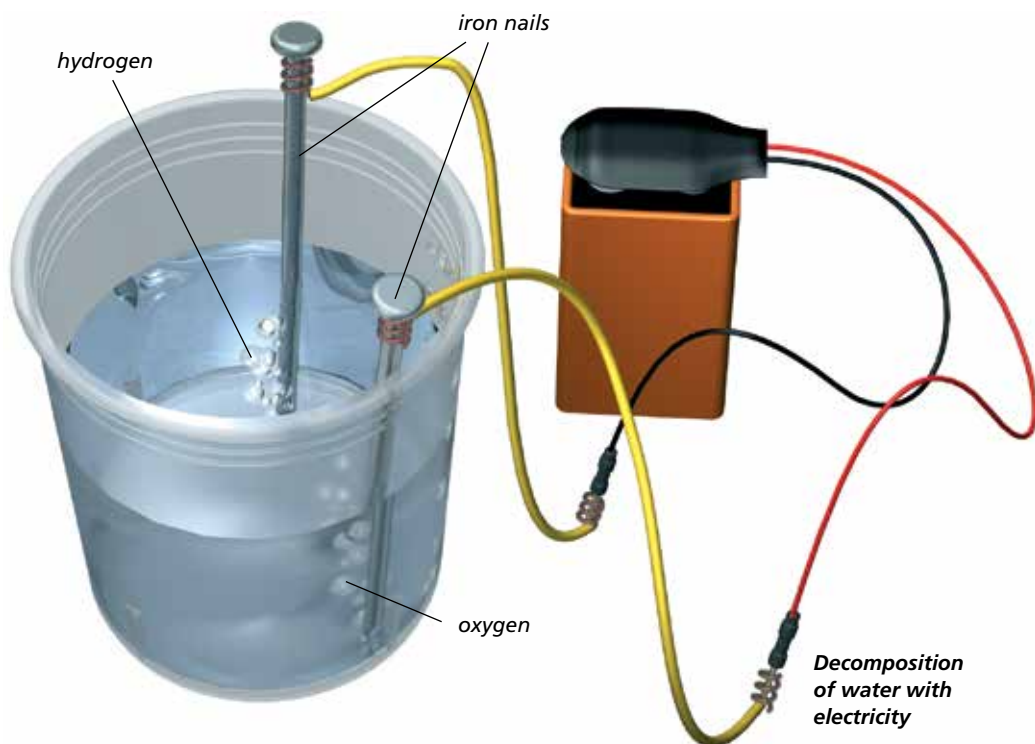

It would be tedious and boring to capture the bubbles of gas and study them. In later experiments, you will be producing larger quantities of the two gases.

Yes, there are *two* different gases: namely, **hydrogen** and **oxygen**. The two gases have combined to form a new substance with completely new properties: **water**. Hydrogen and oxygen are **basic materials** or **elements**, while water is a **compound**.

Basic Knowledge



Elements and compounds

For the Greek Empedocles, who lived in the 4th century BC, water was one of the four elements along with earth, fire, and air, and these elements were held to be the basis of all things. This doctrine of four elements persisted for over 2,000 years. In the 17th century — 1661, to be exact — the term **element** was defined by Robert Boyle (1627–1691) in the way we still understand it today: An element is a material that cannot be decomposed into simpler materials. At present, there are 118 chemical elements known. Composite materials, or **chemical compounds** — which number in the millions — are derived by combining the elements together.

It was not until the 18th century that scientists recognized that water was not an element, but rather a compound. Antoine Lavoisier (1743–1793) obtained hydrogen from water vapor that he conducted across glowing iron filings, and which he was thus able to identify as a component of water. Since hydrogen could be combusted into water in the presence of oxygen (produced for the first time in 1771), it was determined that water is a compound of the elements hydrogen and oxygen.

The table below lists the elements that you will be coming across in your experiments. Three of them — copper, magnesium, and sulfur — appear in elemental form in the kit (as wire, metal strips, or powder), while the others come in compounds. In addition to the English and Latin or Greek/Latin names, the table also contains the symbols for the elements, which you should pay attention to since you will often be needing them later on.

You already saw with the example of water that compounds often have quite different properties from the elements that compose them. This sort of quirk is something you will encounter often in chemistry.



Robert Boyle defined the term “element” in the way we still understand it today (photo: Deutsches Museum, Germany).

With the help of electric current, you can retrieve the elements back out of the compound again. The name for this process is electrolysis (decomposition by electric current; Greek *lysis* = decomposition or splitting). Hydrogen rises up from the nail connected to the negative terminal, while oxygen rises from the one connected to the positive terminal.

Are you wondering if the gases might actually come from the baking soda? Good question. But the two gases really do come from the water, and the baking soda is just there to ensure that the water is sufficiently conductive.

English Name	Latin or Greek-lat. Name	Symbol
Aluminium	Aluminium	Al
Carbon	Carboneum	C
Calcium	Calcium	Ca
Chlorine	Chlorum	Cl
Copper	Cuprum	Cu
Iron	Ferrum	Fe
Hydrogen	Hydrogenium	H
Iodine	Iodum	I
Potassium	Kalium	K
Magnesium	Magnesium	Mg
Manganese	Manganium	Mn
Nitrogen	Nitrogenium	N
Sodium	Natrium	Na
Oxygen	Oxygenium	O
Sulfur	Sulfur	S



Water decomposition apparatus named after A.W. Hofmann (1818–1892), still in use today (photo: Deutsches Museum, Munich, Germany).

The chemical elements that you will encounter in your experiments.



Industrial hydrogen production by the Lurgi pressure electrolysis process (Lurgi factory photo, Germany)

A miniature hydrogen factory



For **calcium hydroxide** and **sodium carbonate**, note the “Hazardous substances and mixtures” information starting on p. 7. Be careful when twisting the angled tube into the stopper! Note the information on pages 13/14. In case of injury: **First Aid 7** (inside front cover).

Ask an adult to help you with this experiment.

EXPERIMENT 23

Additional material: Aluminum foil, tealight candle
Place 4 cm of water, two spoonfuls each of calcium hydroxide and sodium carbonate, and a little strip of

aluminum foil in a test tube. Assemble the experimental apparatus shown in the illustration (you will need a sufficiently deep basin or something to set under it).

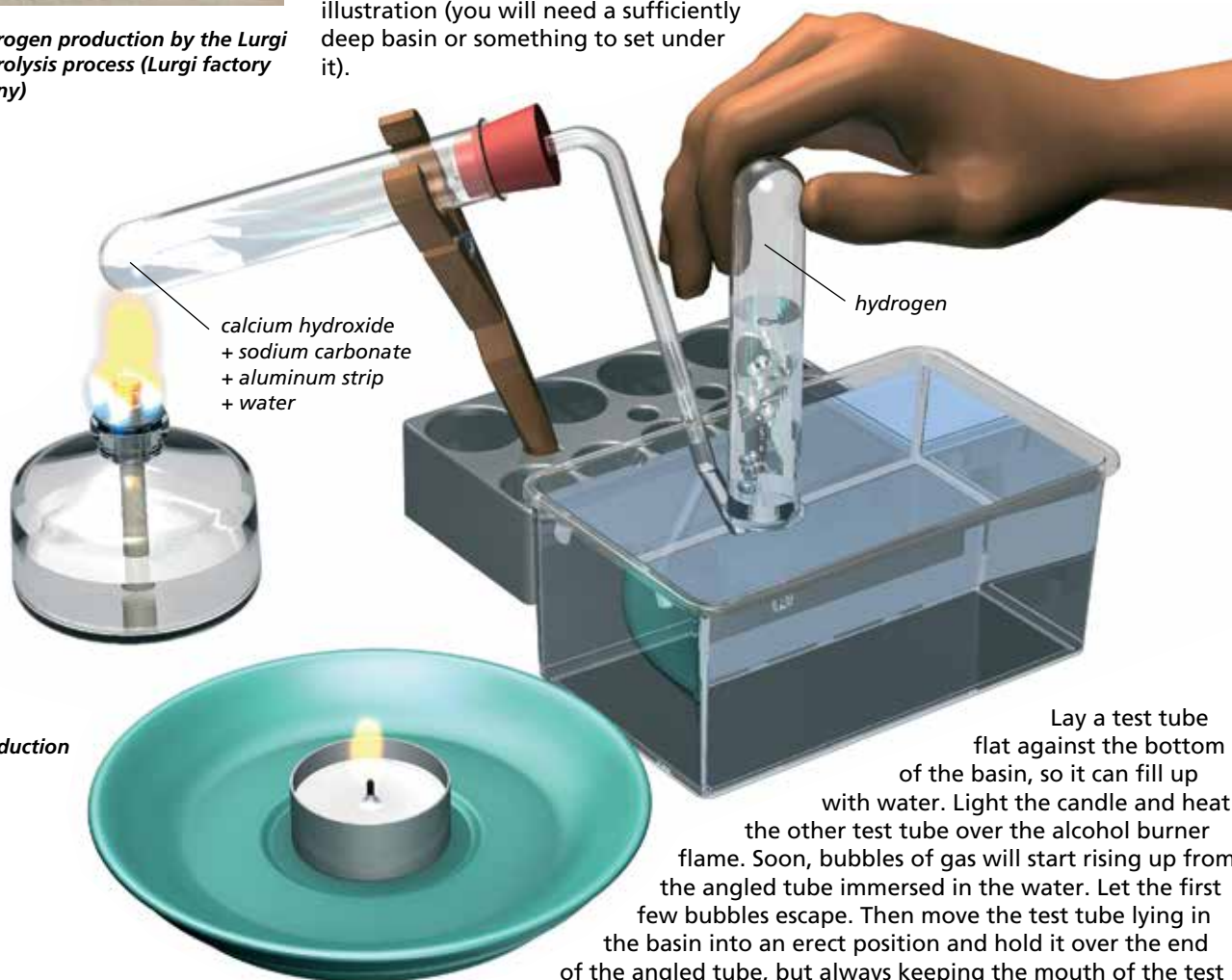

Hydrogen production

A combustible gas



Lay a test tube flat against the bottom of the basin, so it can fill up with water. Light the candle and heat the other test tube over the alcohol burner flame. Soon, bubbles of gas will start rising up from the angled tube immersed in the water. Let the first few bubbles escape. Then move the test tube lying in the basin into an erect position and hold it over the end of the angled tube, but always keeping the mouth of the test tube under water (you will learn in the next chapter how it is that

the water remains inside the test tube). Now the gas bubbles will rise up the test tube and push the water out of it, as you continue to keep its opening under water. With your free hand, move aside the test tube stand with the test tube clamped in it, so the angled tube no longer dips into the water. Disposal after Experiment 25: **A2** Now ask your adult assistant to take apart the apparatus you moved aside and hand you the test tube holder.

EXPERIMENT 24

Clamp the gas-filled test tube in the test tube holder, lift it out of the basin keeping the opening pointed downward, and move it toward the candle flame, as

shown in the illustration. Don't be startled! You will hear a whistling noise and the flame will dart into the test tube.

What happened? The combustible hydrogen combined with the oxygen in the air — more about that in Chapter 4 — with a little explosion. The separated elements are back together again. The tealight candle flame served as the spark.

TECHNOLOGY AND ENVIRONMENT



Hydrogen — Element of the future?

Hydrogen is the lightest of all materials. It is 14 times lighter than air. That is why people used to use hydrogen to fill air balloons and air ships, even though it was not entirely safe due to the combustibility of the gas. There were some serious accidents in which air ships went up in flames. Today, the non-combustible gas helium is used for such purposes.

The interplay of hydrogen and helium as energy sources is of much greater significance. In the sun, there is a constant conversion of hydrogen into helium taking place. In this process, a massive quantity of energy is released, which provides us with light and heat as it is radiated off by the sun.

Here on Earth, the sun's

heat can be captured using solar collectors, or sunlight can be converted into electrical energy by means of solar cells. The electrical energy captured in this way can be used to perform electrolysis on water (Experiment 22). Even now, the hydrogen produced in the process can be used to power vehicles — directly as a fuel for internal combustion engines, or by conversion back into electrical energy with the help of fuel cells, i.e. for electrolysis.

Still, hydrogen produced by solar energy is not yet competitive due to its cost, which is why most hydrogen is obtained from natural gas for now.

From an environmental perspective, it is important to note that hydrogen is the cleanest fuel, since the only waste product created from its use is water.



Solar collector device on the roof of a single-family home



Solar cell array

EXPERIMENT 25

Repeat Experiment 23. Take the hydrogen-filled test tube out of the basin and hold it open-end-down for 3 or 4 seconds. Move the test tube toward the tealight candle

flame, as in the last experiment. You will probably get another little explosion. **A2**

Hydrogen — as already mentioned — is lighter than air. It rises upward unless something prevents it from doing so. So you can hold the gas-filled test tube for several seconds with its opening pointing down, and not much of the hydrogen will escape.

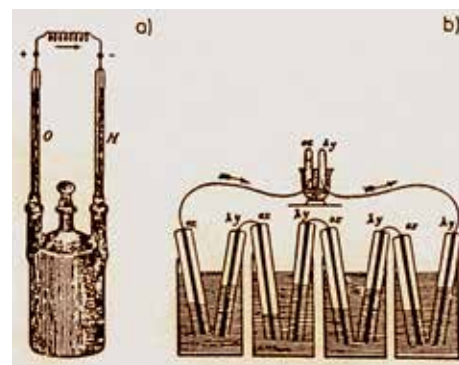

Fuel cells are older than you think. a) fuel cell (1839) and b) gas battery (1842) of William Grove (1811–1896)

Fuel cell car from the Thames & Kosmos experiment kit

4

Fresh Air for our Lungs



To stay under water for long periods of time, people have to carry air with them in pressurized containers.

Air is just as important as water for life. It is no wonder then that Empedocles also counted air among the four elements. Without air to breathe, it would all be over for us even quicker than without water. Even a good diver can only stay under water for three minutes without equipment. And most people value “fresh air” over the “stuffy air” of a crowded room. On the other hand, you don’t really see air. So is air anything at all? Is it a substance?

Air needs room too

EXPERIMENT 26

Fill the basin with water and push a jar open-end-down against the basin’s floor. The water won’t enter the container. Why not? Because there’s already something inside it: air. You can’t see air, or smell, taste, or touch it, but you can observe its effect on visible objects — in this case, water. So the air needs room for itself, and it won’t give up this room so easily. When you pushed down on the jar, you exerted pressure on the air inside it, but the air only became a little bit pushed together in the process, or, in technical terms, compressed.



Question 5. To compress air, it takes some effort. What familiar activity requires this?

EXPERIMENT 27

Push the vertical jar straight down into the water again, but then tilt it a little.

Any air that is located at the same level as water will rise up through the water, since it is lighter than water. Lighter? Does air actually have any weight, or mass, at all?



Air makes biking easier.



Air needs room too.

Air pressure and giant test tubes

EXPERIMENT 28

Lower a test tube into a water-filled basin so that it fills with water (you already practiced this when you were making hydrogen). Orient the test tube vertically again, bottom end up. The water won't run out. You could also try it with a screw-top jar, or a preserving jar. In that case, you will have to first fill the jar with water, screw the lid on, then turn the jar upside down and lower it into the basin. Even after you remove the lid, no water will run out. Air pressure makes sure of that. You could even set a 10-meter-tall test tube in the basin and the water still wouldn't run out. The air pressure will hold back anything up to a 10-meter-high column of water.

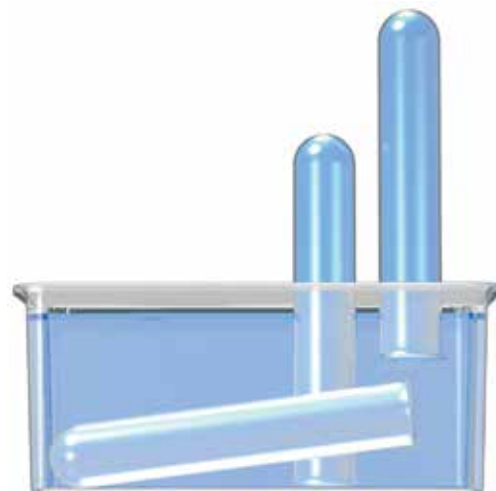

Air pressure ensures that the water stays in the test tube.

The Magdeburg hemispheres, used by Otto von Guericke to demonstrate the power of air pressure (photo: Deutsches Museum, Germany).



Question 6. The column of mercury in a barometer is only about 76 cm tall. Can you figure out why? Read about mercury in an encyclopedia or on the internet.



By the way, air pressure exerts force from all sides, not just from above. There is a well-known experiment based on that, one that has a place in every experiment manual or magic book.

EXPERIMENT 29

Additional material: Cardboard or heavy paper

Fill a graduated beaker or a jar — preferably over the sink — up to the brim with water, and cover the opening with a smooth piece of cardboard or heavy paper. Press the “lid” against the opening, and turn the beaker or jar upside down. Now let go of the lid! Only when the lid is soaked through will the magic end.

Air pressure and temperature

When the air gets warm, the thermometer goes up, or more precisely: the column of liquid in the thermometer goes up. This liquid is usually alcohol these days, or more rarely mercury. The instrument in the next experiment is a kind of thermometer too.

Side Notes

The force of air pressure

The force of air pressure is not something you can feel, because it pushes on you from all sides. But things are different if you get space that is suddenly emptied of air, or a vacuum, inside a closed container.

You might have heard about the Magdeburg hemispheres of Otto von Guericke (1602–1686). He used an air pump that he himself invented to pump practically all the air out of two half-globes, or hemispheres, designed to fit tightly together. Eight horses hitched up on either side had great difficulty pulling the hemispheres apart. That's how hard the air pressure made it for them. Guericke also built a 10-meter-high water barometer that he used to record fluctuations in air pressure.

Guericke's main point was to show that “air is a certain physical something” — no airy phantom, in other words, but material, something with mass and therefore also capable of exerting pressure.



An air thermometer



Be careful when twisting the angled tube into the stopper! Note the information on pages 13/14. In case of injury: **First Aid 7** (inside front cover).

EXPERIMENT 30

Additional material: Red ink (if available), permanent marker

Fill enough water into a test tube so that the bottom end of the angled tube is immersed about 1 cm into it when you insert the stopper. The water will then rise a little way up the tube. If you like, you can dye the water with red ink so you can see it better in the angled tube. Mark its starting point on the test tube wall with a permanent marker, for example. Now set the test tube in a jar of warm water.

EXPERIMENT 31

Take your thermometer out of the warm water and hold it under cold running water. The column of liquid will drop beneath the point where it started.

When it was heated, the air in the test tube expanded and pushed up on the water in the angled tube.



Question 7. How can you explain the behavior of your thermometer when it cooled?



The candles were lit and covered at the same time.

EXPERIMENT 32

You can achieve an even greater cooling effect by setting your thermometer in ice water — that is, water with ice cubes (from the freezer) floating in it. Sometimes, the air in the test tube can contract so powerfully that a few bubbles of air may rise through the water.

Air takes up room, has mass, and expands when heated. It behaves exactly like a substance.

No fire without air

Now let's bring two of Empedocles' elements together. So far, you have been preoccupying yourself with the physical properties of air. Now you will be focusing on the role of air in combustion processes.

EXPERIMENT 33

Additional material: Tealight candle

Light the candle on a fire-resistant surface and set a clean, dry jar over it. In this experiment and the next, you will be studying the walls of the jars.

EXPERIMENT 34

Repeat the experiment, but this time with a larger preserving jar.

The experiments show that in order to burn, the candle needs something that doesn't exist in unlimited quantities under a glass covering, even if the larger jar has more of it than the smaller one.

On the walls of the jars, a coating has formed which — when studied closely — turns out to consist of water. As you learned in the last chapter, water is made when hydrogen combines with oxygen.

There are two conclusions that can be drawn from this:

1. The hydrogen can only come from the tealight candle's fuel, where it hid itself just as effectively as it does in water.
2. The air under the jars consists completely or partly of oxygen.



A boat lift

EXPERIMENT 35

Additional material: Tealight candle, paper clip

Fill the basin 2 cm high with water and float a tealight candle in it. Light the candle and carefully lower a jar over the "boat." Set the jar on the floor of the basin, but in such a way that a part of it is resting on the paper clip.

After the last experiment, you won't be surprised when the candle goes out after a few seconds. But what's interesting is that the water will have risen a little up the jar, lifting the boat with it. Apparently, a portion of the air in the jar has been used up; then, the air pressure pushed the water into the liberated space. If air only consisted of oxygen, the candle would have burned longer and the water would have risen higher. **A1**

That didn't happen. Air is a mixture — not a compound, in other words — of the gases oxygen and nitrogen along with small quantities of other gases. Only the oxygen promotes combustion. Nitrogen is not capable of supporting combustion or breathing.

The pie chart shows the exact composition of the air. Its composition can't be deduced from Experiment 35, in any case, since there are other physical and chemical processes involved: the cooling of the initially-heated air, for example, as well as the creation of space-occupying gases of combustion, which you will be getting to know shortly. The experiment merely shows that only a portion of the air, oxygen, promotes combustion.

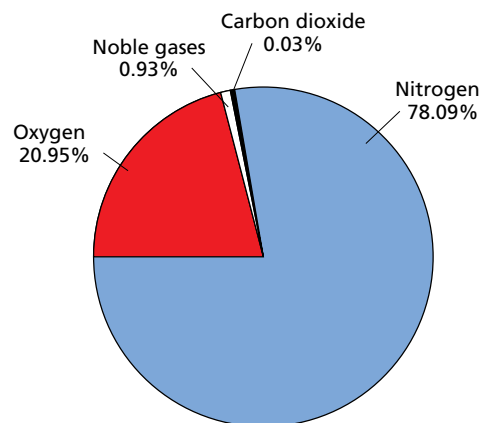

The composition of air

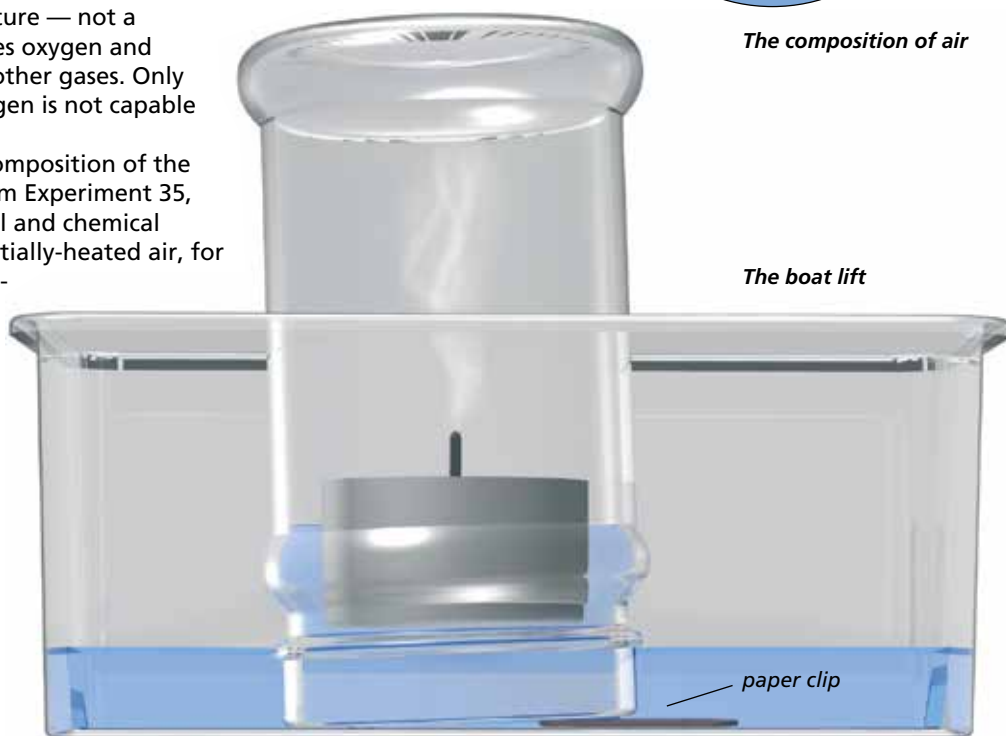

The boat lift

Metals can burn too

You have two thin strips of magnesium in your kit. Use it sparingly with it, because you will be needing it for other experiments as well.



For **magnesium**, note the "Hazardous substances and mixtures" information starting on p. 7. Do not look into the flame! The extreme brightness can harm your eyes. Do not inhale the burning magnesium vapors! Ventilate the room well after the experiment!

EXPERIMENT 36

Additional material: Scissors, pliers

Use the scissors to cut off a piece of magnesium strip about 2 cm in length and hold it in the burner flame with the pliers. After two or three seconds, the magnesium will ignite and burn with an intense light. A few crumbs of white powder will be left behind. **A1**



A picture from the olden days: flashlight powder bag with lighting fuse (photo: Hans Tegen, and Education Home School Book Publishers, Germany).



Magnesium burns with a blindingly bright light.



John Dalton (photo: Deutsches Museum, Germany)

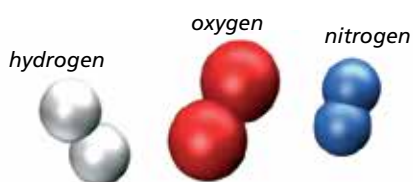

Diatom gas molecule



Water molecule Sulfur dioxide molecule

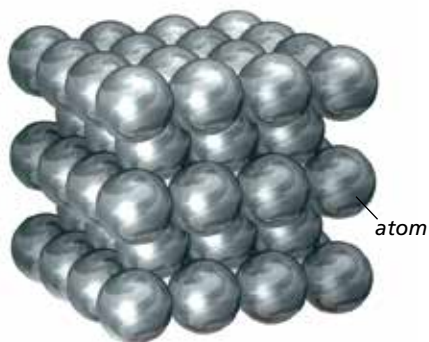

Metal lattice

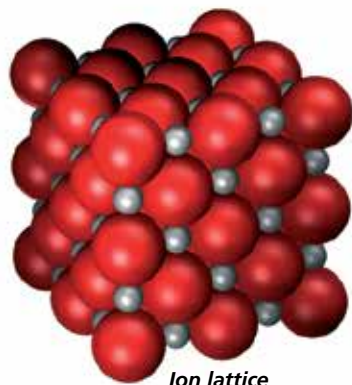

Ion lattice



Molecules and crystal lattices

Basic Knowledge



Atoms and molecules

When we were dissolving materials, or crystallizing substances out of dissolved materials, we spoke of "smallest particles." Are there such things? Isn't it always possible to keep dividing things in two — even if just in theory? The Greek philosopher Democritus (460–371 BC) didn't think so. He posited the existence of smallest particles which could not be divided any further: **atoms** (Greek *atomos* = indivisible).

The atom made its entrance into chemistry with John Dalton (1766–1844). He concluded based on experimental results that any given element is made of identical atoms, while the atoms of the different elements differ from one another. Like Dalton, we picture atoms as tiny balls assembled in different ways, as shown in the illustrations.

Atoms combine with others of their own kind — the atoms of most gases come in pairs — or with the atoms of other elements. In this way, we get individual **molecules** (Latin *molecula* = small mass) or **crystal lattices** containing many thousands of atoms or molecules all lined up in rows. Metal lattices consist exclusively of identical metal atoms, and ion lattices of positively and negatively charged atoms, or so-called ions, which you will soon be learning more about. Among the countless materials formed by molecular lattices is sugar.

How small are atoms? Inconceivably small! One cubic centimeter (cm^3) of a gas contains 269 trillion molecules whirring around in it. That's the number 269 followed by 18 zeros! Even the strongest electron microscope is too weak to render atoms visible. The only thing that can reveal the structure of atoms is a recent invention called a scanning tunneling microscope. But scientists have been convinced of the existence of atoms for a while, since this assumption explained lots of physical and chemical processes.

But it gets better. You might have heard that atoms are by no means indivisible after all, and that they are made of even smaller particles, called **elementary particles**. But that is another topic unto itself, and you don't need to worry about it for now.

EXPERIMENT 37

Additional material: File, iron nail, paper

Over a large sheet of paper, file a small quantity of iron filings off of an iron nail and shake the filings into a chute of paper. Light the alcohol burner and let the filings trickle slowly (!) through the flame, as shown in the illustration. You will get a rain of sparks as the iron particles burn. You may discover a few dark granules left behind as products of combustion. **A1**

As fine granules, the iron filings have a large surface area relative to their mass that is completely surrounded by oxygen-rich air in this experiment. In addition, the iron particles cannot dissipate the heat because they are isolated in the air. So the heat builds up and the required temperature for combustion is reached.

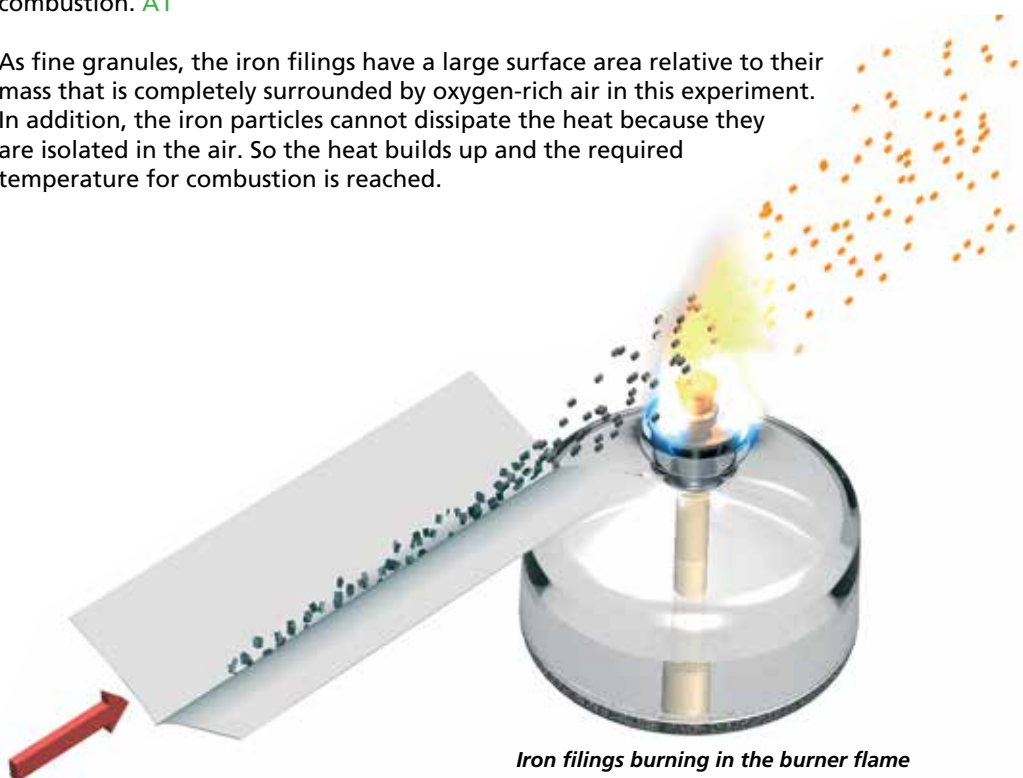

Iron filings burning in the burner flame

When an element combines with oxygen, an oxide is created. This process is known as oxidation. In Experiment 36, you got a white powder — magnesium oxide — and in Experiment 37 an iron oxide (there are several of them), of which you may have been able to gather up a few black granules. When hydrogen is combusted, you would logically think that you would get hydrogen oxide. That is indeed what happens. But the actual name that even chemists give to hydrogen oxide is, simply, water.

Oxidation at a snail's pace

Iron and a lot of other metals normally combine with oxygen without any fireworks — in the case of iron, by rusting.

EXPERIMENT 38

Additional material:
Steel wool, paper clip,
permanent marker

Insert a small ball of steel wool into a test tube and add enough water to thoroughly saturate the steel wool. Set the test tube with its opening downward in a shallow vessel with 1 cm of water in it. Push a paper clip under the edge of the test tube as in Experiment 35.

You will need a little patience for this experiment. Let the experimental apparatus sit for two to three days in a location inaccessible to young children and pets. Then, you will see that the steel wool has turned a brown color in places, and the water has risen slowly up the test tube. Finish by marking the water level on the side of the test tube with the permanent marker.

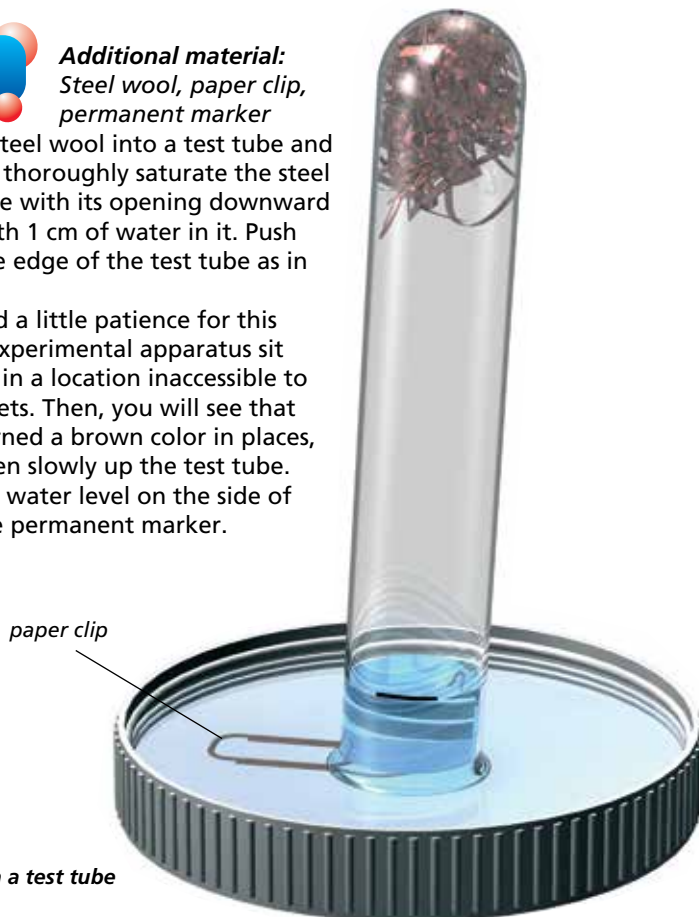

Rust formation in a test tube



Side Notes

Mr. Lavoisier's error

The technical terms oxide and oxidation come from the Greek/Latin *oxygenium*, which essentially means "acid former." The French chemist Lavoisier, whom you already know, supposedly suggested this name for oxygen because he thought that it formed the common, characteristic component of acids. This assumption was wrong, as you will see. But the respect for one of the founding fathers of modern chemistry was so great that this old name was retained in English *oxygen*, French *oxygène*, and German *Sauerstoff* (literally "acid material").

Magnesium — a lightweight



Magnesium is a shiny silver metal that becomes coated with a layer of magnesium oxide when exposed to air, which protects it from further exposure to atmospheric oxygen. Magnesium is combustible, as you could see in Experiment 36. It burns with a harsh white flame, and is used for, among other things, lighting caves. When photography was first invented, mixtures of magnesium powder and oxygen-rich substances were used as flash powder. In later flashbulbs too, magnesium was used to provide the desired brightness.

Magnesium is a base metal which in its natural state appears only in compounds, such as in the mineral dolomite. Metallic magnesium was first released from molten magnesium chloride in 1808, by the English chemist Sir Humphry Davy (1778–1829), using a process of electrolysis.

The first commercial use for magnesium was in fireworks. Today, due to its low density (1.745 g/cm³), magnesium is an important component in light metal alloys, which play an important role in airplane, rocket, and automobile construction, but are also used in a lot of other everyday things. Alloys are metal mixtures of varying compositions.

In the natural world, magnesium performs a lot of tasks. It is a component of the leaf

pigment chlorophyll, and it controls circulatory and metabolic processes such as the decomposition of sugar in the human body.





Components for notebooks, circular saws, and many other everyday objects are made from magnesium alloys in die-casting processes (photo: Stihl Magnesium Die-Casting).



Catalytic converters in motor vehicles convert harmful gases into ones that are harmless or less harmful: carbon dioxide (CO_2), water (H_2O), and nitrogen (N_2) (photo: Volkswagen AG).



Question 8. Which experiment does that remind you of?

You can tell by looking at the mark that the water has taken up about a fifth of the test tube space. This experiment provides pretty reliable information about the composition of the air. Here, there are no interfering side reactions like you had with the floating tealight candle.

Two oxygen sources

There are compounds from which you can release oxygen relatively easily, among which are hydrogen peroxide and potassium permanganate.



For **hydrogen peroxide**, **sodium carbonate**, and **copper sulfate**, note the "Hazardous substances and mixtures" information starting on p. 7.

EXPERIMENT 39

Additional material: Hydrogen peroxide, wooden splint (wooden skewer)

Pour 5 cm of hydrogen peroxide into a test tube and add 1 spoonful of sodium carbonate and 1 spoon tip of copper sulfate. The test tube contents will turn dark blue, and a lively gas production will commence. Light a dry splint of wood (matchsticks are not suitable), blow out the flame, and lower the still-glowing splint into the test tube. When the splint flames up again, it indicates the presence of oxygen (glowing splint test). **A6**

EXPERIMENT 40

Additional material: Dry yeast, hydrogen peroxide, wooden splint (wooden skewer)

Place 1 spoonful of yeast in a test tube and add 1–2 cm of water. Close the test tube with the rubber stopper and shake vigorously to distribute the yeast as evenly as possible through the water. Add the same amount of hydrogen peroxide, remove the foam with the double-headed measuring spoon, and perform the glowing splint test after one minute. **A1**

Hydrogen peroxide is a compound that easily decomposes and gives off oxygen. The decomposition is facilitated and accelerated by certain materials known as catalysts. The catalytic converters in motor vehicles owe their name to the fact that the detoxification of harmful emissions takes place with the help of this kind of reaction accelerator. In Experiment 39, the dark copper oxide created from copper sulfate acted as a catalyst, and in Experiment 40 it was the enzyme catalase contained in the yeast. Catalase also decomposes hydrogen peroxide inside your body, by the way, which arises during metabolic processes but, as a cellular poison, cannot be tolerated by the bodily organism.

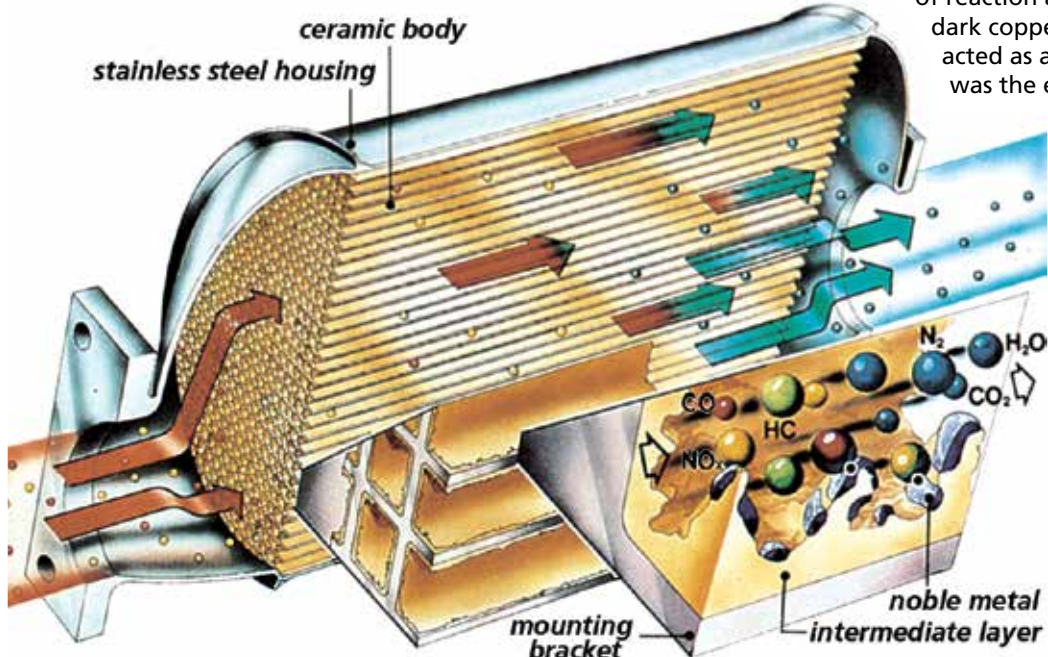

Another oxygen-rich compound that readily releases oxygen is potassium permanganate. In addition to oxygen, potassium permanganate contains the aggressive light metal potassium, which flams up in reaction with water, and the heavy metal manganese, which takes on the most varied colors in its compounds: colorless, brown, green, or violet. You will be using a potassium permanganate mixture in which the potassium permanganate is "diluted" with sodium sulfate.

EXPERIMENT 41

Additional material: Hydrogen peroxide, wooden splint (wooden skewer)

Add 1 spoonful of potassium permanganate mixture to 1 cm of hydrogen peroxide solution and perform the glowing splint test. **A6**



For **potassium permanganate**, note the "Hazardous substances and mixtures" information starting on p. 7. Be careful when twisting the angled tube into the stopper! Note the information on pages 13/14. In case of injury: **First Aid 7** (inside front cover).



Dissolving a potassium permanganate crystal. Potassium permanganate is an extremely color-intensive compound. A tiny grain of it will turn a jar full of water deep purple.

Pure oxygen

In Experiments 39–41, the air in the reaction vessels was enriched with oxygen. This enrichment was sufficient to make the glowing splint flame up again. Now, it's time to make some undiluted oxygen.

EXPERIMENT 42

Assemble the experimental setup in the illustration, which you already know from the hydrogen-production experiment

(you will also need a deep enough basin in this experiment). Seal the hole in the cork stopper with a little ball of paper or clay.

Measure 5 spoonfuls of potassium permanganate mixture into the tilted test tube. Lay two test tubes flat against the bottom of the water-filled basin.

Heat the potassium permanganate mixture. Soon, bubbles of gas will start coming out of the angled tube. Let the first few escape. Then, hold one of the water-filled test tubes over the end of the tube, always keeping its opening under water. The rising gas bubbles will push the water out of the test tube. Once the test tube is completely filled with gas, close it under the water with the rubber stopper and set it upright in the test tube stand.

Now fill the second test tube with oxygen in the same way, close it under water with the prepared cork stopper, and set it in the test tube stand as well.

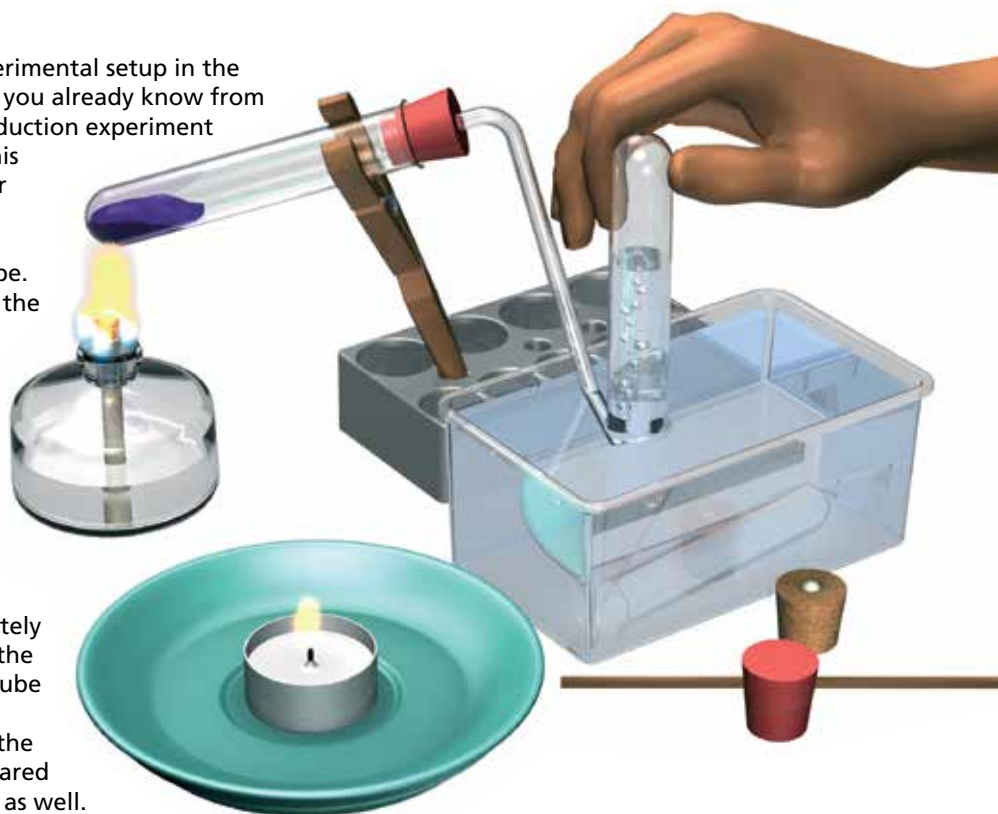

Move aside the test tube stand with the heated test tube, so that the angled tube no longer dips into the water!

For disposal, pour the residue from the heated test tube into a jar, add 1 cm water, and add hydrogen peroxide up to the point that the violet color of the potassium permanganate disappears: **A8**. Cleaning of the test tube: **A7**

Test for oxygen (glowing splint test)

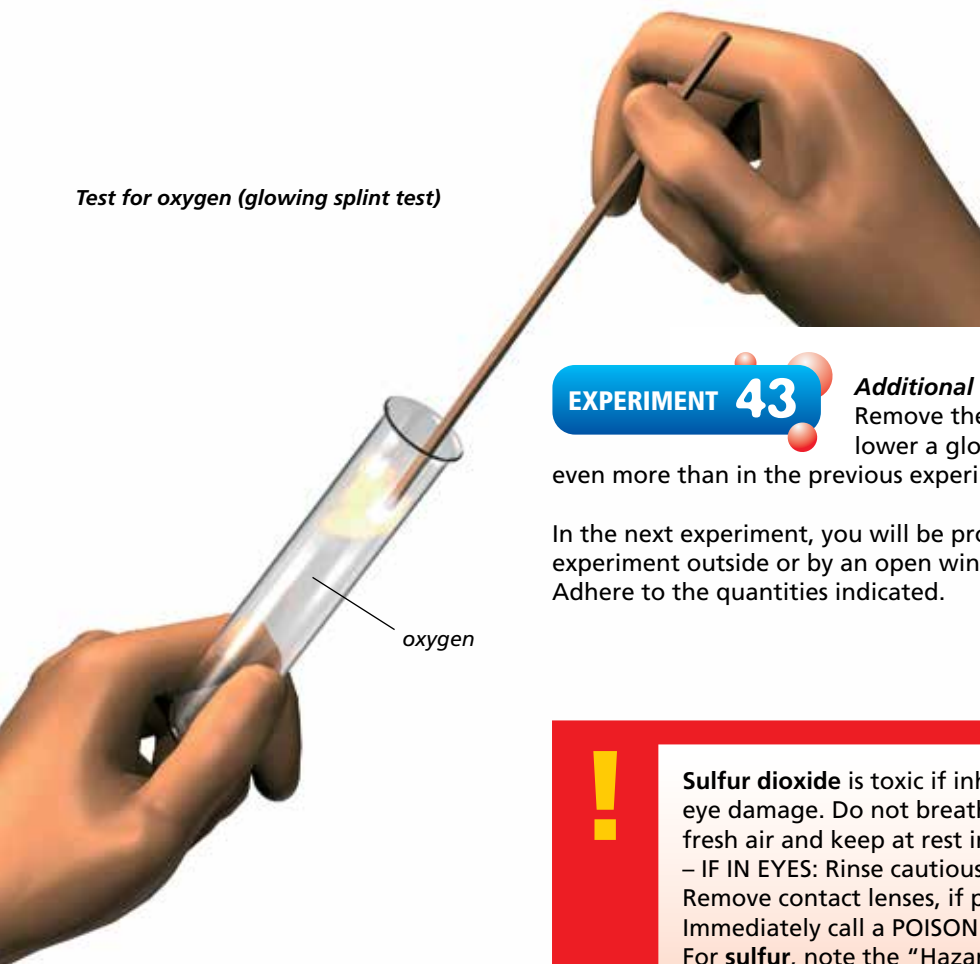

EXPERIMENT 43

Additional material: Tealight candle, wooden splint
Remove the stopper from the first gas-filled test tube and lower a glowing splint into the test tube. It will flame up even more than in the previous experiments.

In the next experiment, you will be producing a harmful gas. Perform the experiment outside or by an open window. Ventilate well following the experiment. Adhere to the quantities indicated.



DANGER



Sulfur dioxide is toxic if inhaled and causes severe skin burns and eye damage. Do not breathe gas. – IF INHALED: Remove victim to fresh air and keep at rest in a position comfortable for breathing. – IF IN EYES: Rinse cautiously with water for several minutes. Remove contact lenses, if present and easy to do. Continue rinsing. – Immediately call a POISON CENTER or doctor. For **sulfur**, note the “Hazardous substances and mixtures” information starting on p. 7.

EXPERIMENT 44

Bend the double-headed measuring spoon as shown in the illustration, and half-fill the small end with sulfur. Hold the end with the sulfur in the burner flame. The sulfur will light and burn with a small, weak flame. Remove the stopper from the second oxygen-filled test tube and lower the spoon with the burning sulfur into it. The small flame will get noticeably brighter.

The sulfur has combined with the oxygen to form **sulfur dioxide**.

Cleaning the double-headed measuring spoon: Clamp the large end of the spoon in the test tube holder and, outside in the open air, hold the small end in the burner flame until the sulfur residues have completely burned away.

The double-headed measuring spoon as combustion spoon



In a cutting torch, hydrogen or acetylene reacts with pure oxygen to produce temperatures of up to 3,300 °C.



Basic Knowledge



The secret of chemical formulas

You got to know the symbols for the chemical elements in the table on page 23. For chemists, these are more than just abbreviations. The symbol H would be read as "1 atom of hydrogen," the symbol O as "1 atom of oxygen." For the hydrogen and oxygen gas molecules consisting of 2 atoms each, you would write H₂ and O₂. The subscript numbers indicate that the relevant atom occurs more than once (in these cases, twice) in the molecule.

If you want to write the **formula** of a chemical compound, you line up the symbols of the elements contained in it one after the other. The hydrogen molecule consists of 2 atoms of hydrogen (H) and 1 atom of oxygen (O). The formula for water thus ends up as HHO or — according to the usual way of writing it — H₂O. Similarly, the formula SO₂ indicates that 1 sulfur atom (S) combines with 2 oxygen atoms in the sulfur dioxide molecule. The syllable di in the compound's name indicates that the portion following it (in this case, oxygen) appears twice.

There are no molecules for sodium chloride (table salt). Here, the formula NaCl signals the fact that one charged chlorine atom appears for each charged sodium atom in the crystal lattice — other words, that the compound contains an equal number of sodium and chlorine atoms.

You can use formulas to write chemical reactions in a brief and clear manner:

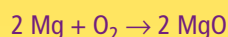
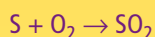

To the left of the reaction arrow, we have the starting materials, and to the right we have the reaction products. The entire thing is called a **reaction equation**. Please note that it really is an equation. The number of individual atoms to the left and right of the reaction arrow must match.



Question 9. You haven't encountered chlorine (Cl) yet. Still, you should be able to say if the following reaction equation is correct:

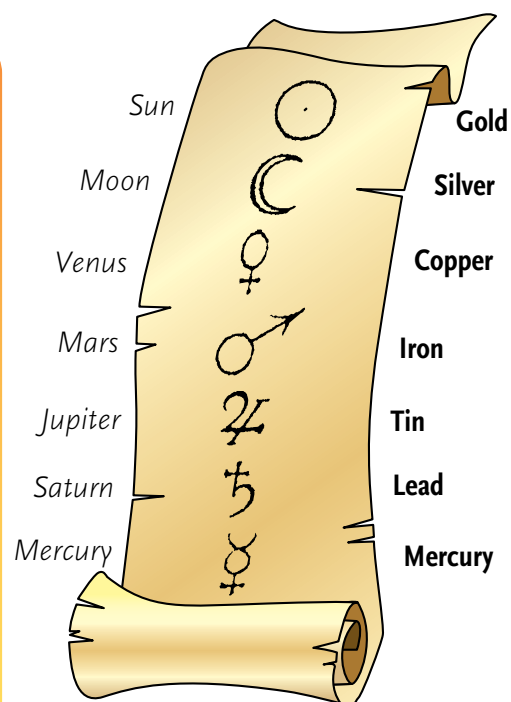
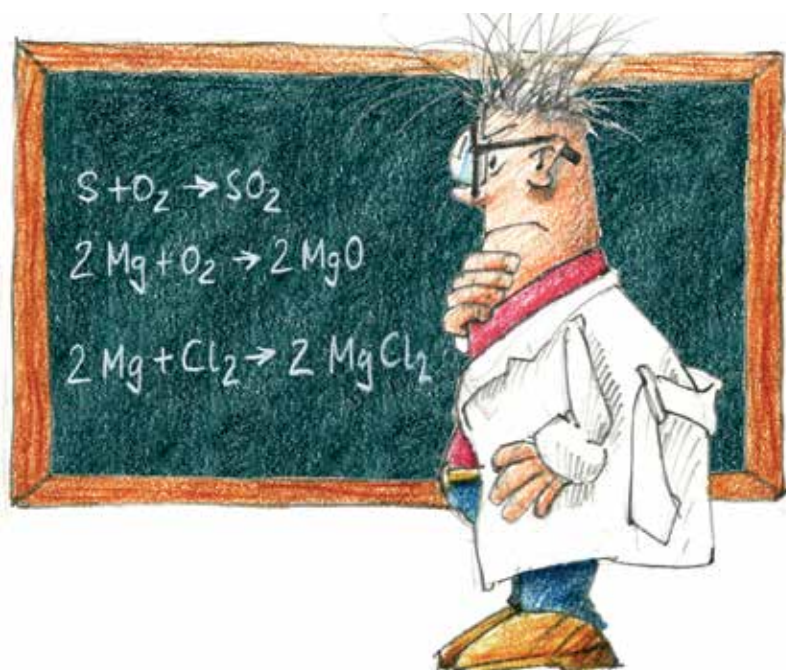
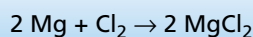

Symbols for metals and the heavenly bodies assigned to them — an early example of chemical symbology.



Look into a 16-century laboratory (from Lazarus Ecker's Treatise on Metallic Ores, 1574)

5

Acids, Bases, Salts



Two dangerous liquids — hydrochloric acid and lye — make sodium chloride, the main ingredient (over 97%) in table salt, which is essential to life.

We encounter acids all the time in our everyday lives. We use vinegar and lemon juice to flavor our food. The active ingredients of these acidifying agents are acetic acid and citric acid (chemists write citric acid with a C). You also know that fruits contain acids. An ingredient in a lot of soft drinks (for example, cola) is phosphoric acid. Hydrochloric acid — one of the most important acids in the lab — is produced in your stomach. Without sulfuric acid, car batteries wouldn't work.

The opposing players of acids are called alkalis, an important group of materials. They are also known as bases or lye.

Salts are created when, for example, acids and alkalis react to each other. Table salt is not the only kind of salt. Most of the chemicals in your experiment kit, in fact, belong to the salts group.

Introducing an indicator

As mentioned, you already know acids from the kitchen. The sour taste of vinegar and lemon juice is familiar to you. You can't put the chemist's acids or sulfuric acid from a car battery to a taste test, since these are caustic, and in some cases toxic, liquids. To detect acids and bases, there are things known as indicators (from Latin *indicare* = to indicate or show). These are substances that announce the presence of an acid or base by changing color.

One such indicator is litmus. Your C2000 chemistry lab includes litmus powder, which you will use to make deep blue litmus solution. In your experiments, you will either be using the solution or strips of filter paper saturated with the solution: litmus paper.

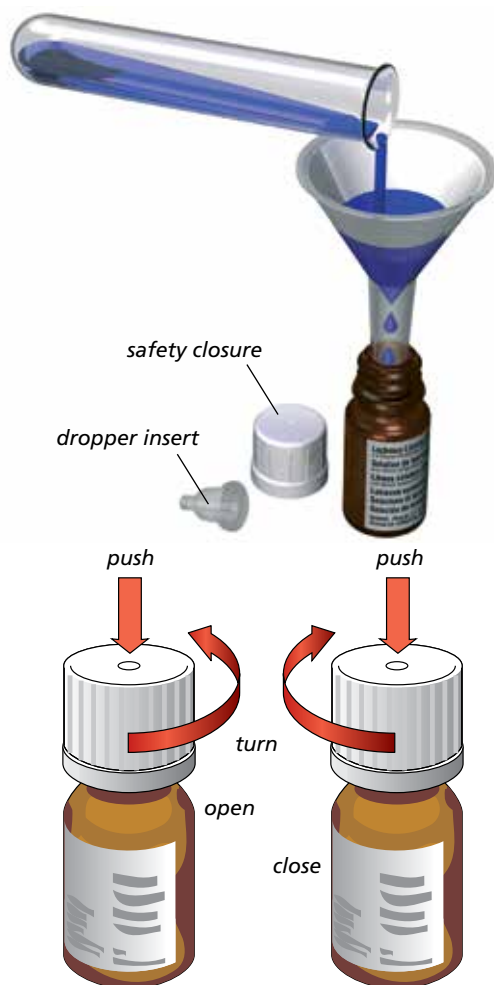

How the litmus solution vial's safety closure works.

Making litmus solution

Litmus powder is not a single substance. It is a mixture of things from various plants known as lichens. Litmus solution will only keep for a limited amount of time, and it can start to smell differently if kept too long (the dry powder has an earthy smell). The quantity of powder is intended to be enough to let you make three small batches of solution. For one batch, measure 3 small level spoonfuls of litmus powder in a test tube, add 3 cm water, close the test tube, and shake. Let the closed test tube sit for one day in a spot that is inaccessible to young children.



For **denatured alcohol**, note the "Hazardous substances and mixtures" information starting on p. 7.

Now set the funnel, with a filter placed inside it, into the vial with the "litmus solution" label and decant the contents of the test tube onto the filter. The residue that remains behind in the test tube and on the filter can be disposed of in the trash.

The shelf life of the litmus solution can be increased by adding half a pipette full of denatured alcohol. Ask your adult assistant to handle this for you. Then close the vial with the safety closure, which will push the dropper insert into the neck of the vial. When you refill the vial, the dropper insert will first have to be removed (have an adult help you). The illustration shows how to open or close the safety cap by simultaneously pushing down and turning. Now the litmus solution is ready. You will find instructions for making litmus paper just before Experiment 51.

Acids and bases

Start your investigations with acids from the kitchen.

EXPERIMENT 45

Additional material: *White vinegar*

Measure 3 cm water and two drops of litmus solution into a test tube. The diluted solution will be light blue.

Add some white vinegar (or white wine vinegar) to it drop by drop: The color will switch from blue to light red. If you add some more vinegar, the red color will barely change. If you keep adding the indicator, the color will turn more intense. Save the solution for Experiment 48.

If you proceed as in this last experiment — adding a few drops of vinegar to the blue litmus solution — the red coloration will work successfully with most kinds of vinegar. But if you turn things around and add a few drops of litmus solution to the vinegar, a dark vinegar color will often conceal the color change. The best thing to use in your experiments is colorless vinegar, which an adult can buy for you. Distilled white vinegar with 5% acidity is recommended.



Many different kinds of vinegar, varying in color and flavor



For **citric acid** and **sodium carbonate**, note the “Hazardous substances and mixtures” information starting on p. 7.

EXPERIMENT 46

Additional material: *Lemon juice or citric acid*

Proceed as in the previous experiment, but this time investigate the effect of a few drops of lemon juice

or citric acid solution (1 small spoonful in 3 cm water) on the litmus solution. The citric acid contained in lemon juice will turn blue litmus solution red too. Save the solution for Experiment 48.

EXPERIMENT 47

In a test tube, dissolve 1 spoonful of sodium carbonate in 1 cm of water and rub a little of this solution between your thumb and forefinger. You may not

feel much at first. But then — even after you have rinsed off your hands — the “treated” skin will feel a little different: smoother, less dull than when you rub the fingers of your other hand. **A1**

A solution of sodium carbonate in water will form **sodium hydroxide** or lye (see page 43 f.), which softens the skin a little. If you work for a while with soapy water, such as when you’re doing some cleaning, you will get the same feeling. That’s because a little lye will form in soap solutions and sodium carbonate-containing cleaning solutions as well. Lye plays an important role in labs and factories. The rub test would be as rarely used with highly concentrated forms of it as the taste test would be used with acids. But the indicators that point to acids also announce the presence of lye by changing their color. Litmus is no exception.

EXPERIMENT 48

Dissolve 1 spoonful of sodium carbonate in 5 cm water and add this solution drop by drop to the red solutions from Experiments 45 and 46. The red will disappear, and the litmus blue will return. Set aside the solutions for Experiment 50.

EXPERIMENT 49

Additional material: *Bar of soap*

Scrape a few shavings off the bar of soap and shake them along with 5 cm water in a test tube. Prepare a red litmus

solution as in Experiment 45 and add some of the soap solution to it. Once again, the red of the acid solution will give way to the litmus blue. You will probably have an idea about how you can bring back the red color again.



Bars of soap come in lots of different sizes and colors too.



Litmus solution with citric acid (left) and sodium carbonate (right)

EXPERIMENT 50

Add a few drops of vinegar to the blue solution from the last experiment. Hurray! The red is back! **A1**

Sodium carbonate solution and soap solution both show the same reaction to acidic (red) litmus solution, from which we can conclude that in both cases — as mentioned — some lye is produced. Other bases (such as potash) behave the same way. Based on these observations, we can determine:

- **acids** color blue litmus solution red (acidic reaction)
- **bases** (alkali solutions) color red litmus solution blue (alkaline reaction)

Acids in juices and drinks

In many cases, a test with litmus paper is easier than one with litmus solution. So now you will learn the technique for making blue and red litmus paper.

Cut strips of filter paper about 1 cm wide and 3–4 cm long, and soak each one with 1–2 drops of litmus solution. Let the strips dry on a paper towel. Now you have blue litmus paper.

Color a few of the blue strips red with 1 drop of vinegar and rinse them very briefly (!) under running water. Then, let the red strips dry as well. Do not make too much red litmus paper, since the strips will gradually turn blue again. You should always keep a few red strips around, though, to serve as a quick test for alkaline solutions (keep them in a cardboard box).



EXPERIMENT 51

Additional material: Sour, unripened apple

To test for the acid in an apple, you won't have to make apple juice first. Just cut off a narrow slice of the apple to be tested and press a blue litmus paper strip against the surface of the slice. **Apple slice: A3**

EXPERIMENT 52

Additional material: Sweet, ripe apple

Repeat the previous experiment with a ripe apple. You will be astounded. Even ripe fruit contains enough acidity to turn blue litmus paper red. **Apple slice: A3**



Acids in juices and drinks



Question 10. How can you perform an experiment to prove that acid isn't "eliminated" by sugar? As the acid, use the 5% acetic acid solution.

Versatile citric acid: it gives jelly a delicate tartness, and gets rid of calcium deposits.



Apples contain **malic acid** and a little citric acid. The acid content does drop as they ripen, but even in a ripe apple it is still detectable.

For the next experiment, you will need a small amount of **white wine**, which you should ask an adult to get for you.

EXPERIMENT 53

Test for the tartaric acid in wine by adding 2 drops of litmus solution to 2–3 cm of wine. **A1**

EXPERIMENT 54

Additional material: Cola drink

To test for the acid in a cola drink, pour 2 cm of it into a test tube and then fill the test tube the rest of the way with water. The contents will only show a weak color now. Add 4–5 drops of litmus solution to 2 cm of the diluted cola solution. The red coloring indicates acid. The acid test will work even more clearly if you drip a few drops of the cola solution onto blue litmus paper. **A1**

Cola drinks contain citric acid and **phosphoric acid**, which intensifies the effect of the caffeine “pick-me-up.”

Acids give juices and drinks a refreshing taste. By contrast, most people have a natural dislike of alkaline drinks, such as mineral waters containing sodium bicarbonate (also called sodium hydrogen carbonate or baking soda) or other alkaline salts. To test for an alkaline reaction in a sodium bicarbonate solution, use red litmus paper.

EXPERIMENT 55

Additional material: Baking soda (sodium bicarbonate)

Dissolve 1 spoonful of baking soda in 3 cm of water and place 1 drop of this solution on red litmus paper. The blue color indicates an alkaline reaction. **A1**

The indicator from red cabbage

Litmus isn't the only plant dye that shows different colors when combined with acidic or alkaline solutions. Lots of other plant dyes can do that too, such as the one in red cabbage (which often looks blue), as well as blueberries, black currants, and a lot of other flowering plants. These are all grouped under the heading anthocyanins (Greek *anthos* = flower, *kyanos* = blue). Like litmus, they are all colored red by acids. In alkaline solutions, they display a green, or sometimes yellow color tone, not the full blue of the litmus dye.



Side Notes

Citric acid

Citric acid is widely used today as an acidifier, such as in the production of jams and jellies. Citric acid is cheaper than lemon juice, since it is produced primarily from residues left over during sugar production rather than from lemons. The conversion of sugar into citric acid, which takes place with the help of a fungus called *Aspergillus niger*, is a biotechnological process resting on a discovery that goes all the way back to 1893. It isn't just in the food industry that citric acid has an important role to play, by the way. It is also an ingredient in a lot of cleaning products. Citric acid was first produced from lemon juice in 1784. The juice was treated with calcium hydroxide, and the calcium citrate that arose by that process was then converted into gypsum and citric acid with the use of sulfuric acid.



The fungus *Aspergillus niger* converts waste products from sugar production into citric acid (photo: Jungbunzlauer Ladenburg GmbH).

Indicators from the garden

TIP
Ask your adult assistant to add half a pipette of denatured alcohol to the anthocyanin solution. Adding the alcohol improves the shelf life of the homemade indicator solution. (You must note the addition of denatured alcohol on the label).

EXPERIMENT 56

Ask an adult to help you with this experiment. Chop up the leaves of red cabbage (or another indicator plant) and boil them in the kitchen in a small pot for about 15 minutes. Filter the liquid into a graduated beaker after it has cooled off a little. Keep your indicator in a small, clean bottle, and attach a label to the bottle: **Anthocyanin solution**. Also note on the label which plant you got the solution from. You can saturate a few strips of filter paper with the solution and let them dry. Now, in addition to litmus paper, you have some **anthocyanin paper**.



For **denatured alcohol** and **sodium carbonate**, note the "Hazardous substances and mixtures" information starting on p. 7.

EXPERIMENT 57

Pour 5 cm of vinegar into a test tube and add half a pipette of anthocyanin solution. You'll see a red color. **A1**

EXPERIMENT 58

In a test tube with 5 cm of water, dissolve 1 spoonful of sodium carbonate and add half a pipette of anthocyanin solution. Now you'll see a green color. Treat the green solution with some vinegar: The red coloring comes back, even if only as a weak pink. You might see a transitional purple color. **A1**



Anthocyanin solution and anthocyanin paper

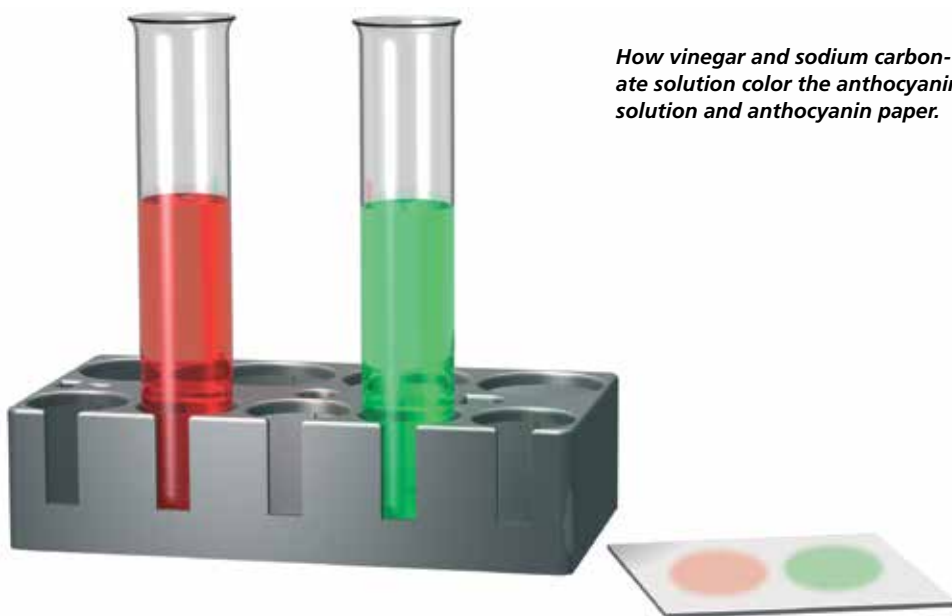

How vinegar and sodium carbonate solution color the anthocyanin solution and anthocyanin paper.

It won't work without water



For **citric acid**, note the "Hazardous substances and mixtures" information starting on p. 7.

EXPERIMENT 59

Additional material: Citric acid
Lay a piece of blue litmus paper on a light-colored background and place 1 small spoonful of citric acid on the strip. Can you see a red coloration? Drip a few drops of water onto the citric acid. **A1**

EXPERIMENT 60

Repeat the experiment where you add sodium carbonate to red litmus paper. Here too, the expected color reaction only occurs after adding water. Apparently, acids and alkalis must be present in a dissolved form for their acidic or alkaline effect to show itself. You will find out why that is in the next section. **A1**

Metals drive out hydrogen

In Experiment 23, you produced hydrogen from an alkaline solution. What's more common is the release of hydrogen from acids. Have an adult help you with this experiment.



For **magnesium**, note the "Hazardous substances and mixtures" information starting on p. 7. Be careful when twisting the angled tube into the stopper! Note the information on pages 13/14. In case of injury: **First Aid 7** (inside front cover).

EXPERIMENT 61

Additional material: Tealight candle, large clothespin
For this and the following experiment, assemble the same apparatus as in Experiment 23. Place a 5 cm-long, double-folded magnesium strip in the test tube and pour 2 cm of vinegar over it. Immediately close the test tube with the stopper and angled tube and clamp it in the test tube holder as shown in the illustration. Light the tealight candle.

Hold a water-filled test tube over the end of the angled tube to catch the escaping gas bubbles. You will have to wait patiently for the test tube to fill with gas. Take the test tube open-end-downward out of the basin, clamp it in the clothespin, and move it toward the flame as in Experiment 24. Don't be alarmed! **A1**
In the reaction of acetic acid with magnesium, hydrogen is created.

EXPERIMENT 62

Additional material: Tealight candle, large clothespin, citric acid

Place a 5 cm-long magnesium strip in a concentrated citric acid solution (3 spoonfuls of citric acid in 2 cm of water) and capture the gas escaping from the angled tube as you did in the previous experiment. Again, it will take a while for the test tube to fill up. Take the test tube out of the basin, clamp it in the clothespin, and bring it toward the tealight candle flame. The explosion will show that hydrogen was created. **A1**

You could continue the experiments with other acids and other metals.

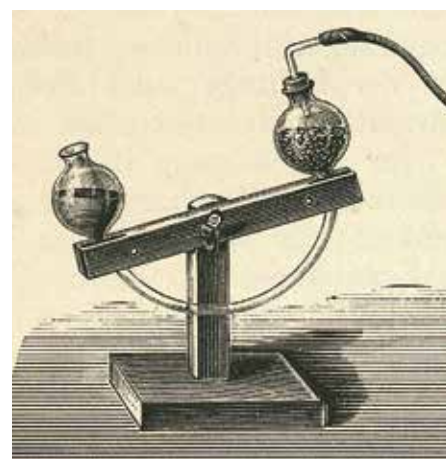
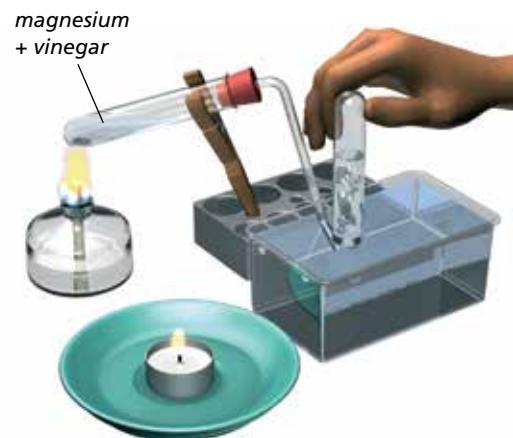

Another "Kipp" device, designed to supply hydrogen as long as the acid has contact with the metal. From: F. Krafft, *Inorganic Chemistry* (1891)

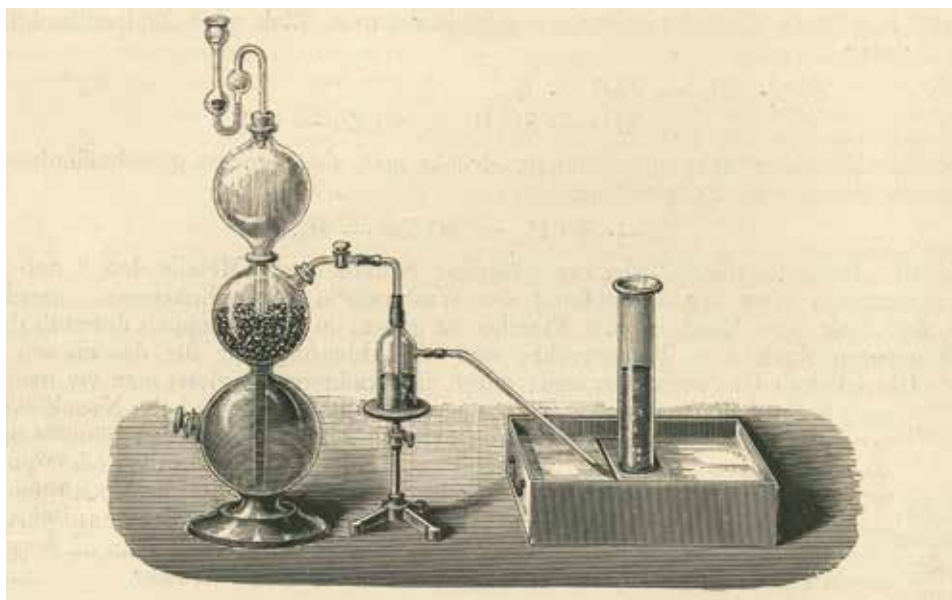

Hydrogen production with a device invented by P.J. Kipp (1808–1864). The ball in the middle contains zinc, while the upper and lower ones contain acid. When the tap is opened, the acid reacts with the zinc. If the tap is closed, the gas pushes the acid away from the zinc, and the gas production stops. From: F. Krafft, *Inorganic Chemistry* (1891)



Justus von Liebig (1803–1873) — one of the most important chemists of the 19th century — noted in 1839: “Acids are... hydrogen compounds in which the hydrogen can be replaced by metals.” (Photo: Deutsches Museum, Germany)

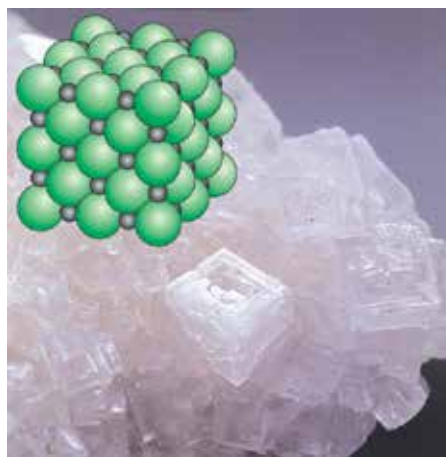

The organization of ions in table salt (sodium chloride) produces cubic crystals (sodium gray, chlorine green).



Basic Knowledge

Hydrogen ions, or what makes acids acidic

It isn't oxygen that makes acids taste sour or acidic, as Lavoisier assumed, but hydrogen. As the 19th century progressed, scientists came to understand that acids are made of hydrogen and an acid residue.

The structure of hydrochloric acid, which you will encounter in Chapter 8, is especially simple. Specifically, it involves the gas hydrogen chloride, which produces hydrochloric acid if dissolved in water. The hydrogen chloride molecule (HCl) consists of 1 atom of hydrogen (H) and 1 atom of chlorine (Cl). In solutions in water, the hydrogen chloride molecule breaks down into positively-charged hydrogen particles (H⁺) and negatively-charged acid residue particles (Cl⁻).



These charged particles are called ions, because they “wander” (ion comes from the Greek verb meaning “to go”) in the electrical field, such as in the kind of electrolysis you performed in Experiment 22. You will be making ions wander in Chapter 8. The hydrogen ions (H⁺) are responsible for the acidic reaction of solutions in water. They are the things that make acids acidic.

Hydrogen ions are also involved when metals drive off hydrogen. The hydrogen ions give off their positive charge to the metal, which dissolves into positively-charged metal ions. The discharged hydrogen ions escape as hydrogen gas (which you captured in Experiments 61 and 62). The metal ions that are created now take the position in the acid residue ions that the hydrogen had previously occupied in the acid. An exchange of partners has taken place:

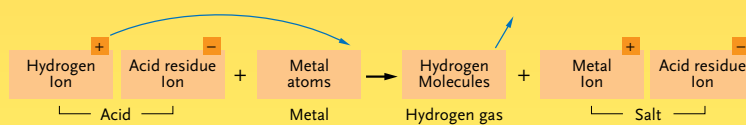

If you evaporate the solution, the metal and acid residue ions get together into an ion lattice. It's easy to see that the organization of Na⁺ and Cl⁻ ions in the sodium chloride gives rise to cubic crystals. Materials that form ion lattices are called salts. As we already said: Table salt isn't the only salt.

From limewater to lye



For **calcium hydroxide** and **limewater**, note the “Hazardous substances and mixtures” information starting on p. 7.

EXPERIMENT 63

Add 2 spoonfuls of calcium hydroxide to a graduated beaker filled halfway with water, put the lid on the beaker (make sure it's tight all around!) and shake. The white liquid is also called milk of lime due to its appearance, but obviously you should never drink it. If you let the milk of lime sit a little while, the white powder will settle to the bottom and the liquid above it will turn clear again.



Question 11. What conclusion could you draw from this observation?

EXPERIMENT 64

Set a three-layered filter cone in the funnel and filter the milk of lime after shaking the sealed graduated beaker one more time. Add 1 drop of the filtrate to some red litmus paper or anthocyanin paper. Of course, you could also perform the test with the indicator solutions. Apparently, some calcium hydroxide must have dissolved, with most of it left behind on the filter paper. The clear, alkaline-reacting liquid is known as limewater. Limewater is an important indicator for the “greenhouse gas” carbon dioxide, so you can save it for later experiments in a labeled bottle. Otherwise: **A1, residue: A3**

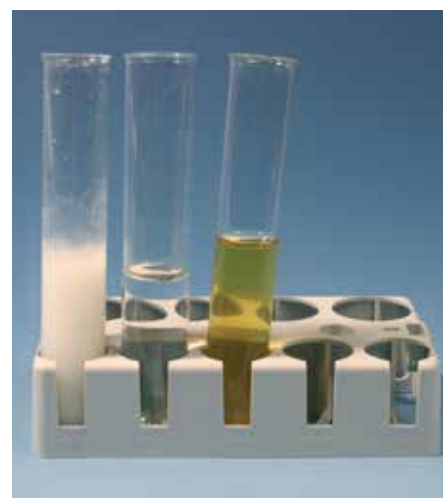

Milk of lime, limewater, and limewater with anthocyanin solution

Basic Knowledge



The opposite numbers of hydrogen ions

The hydrogen ions, or H^+ ions, are responsible for the acidic reaction. What's behind the alkaline reaction? That would be hydroxide ions. Hydroxides consist of positively-charged metal ions and negatively-charged hydroxide ions (OH^-). In a solid substance, the opposite-charged ions form an ion lattice, as in salts. In a solution, the ions are able to move freely.

Calcium hydroxide — $Ca(OH)_2$ — decomposes into two positively-charged calcium ions (Ca^{2+}) and hydroxide ions (OH^-):



If acidic and alkaline solutions are mixed together, the H^+ ions combine with OH^- ions to form water:

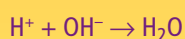

This process is known as neutralization. Water, after all, is neither acidic nor alkaline, but neutral (from Latin *neuter* = neither one).

Another comment for those who are especially curious: The H^+ ions are much tinier than the H atoms, so they try to join up with H_2O molecules. This is how H_3O^+ ions, or hydronium ions, arise. But when things get serious — that is, when the reaction occurs — the H^+ ions jump off, say “Thanks for the ride!” and launch themselves into a new adventure, e.g. in the arms of OH^- ions in the neutralization process just described. For the sake of simplicity, in this manual we will stick with hydrogen ions (H^+).

DANGER



Soda lye causes severe skin burns and eye damage. Wear protective gloves, protective clothing and eye protection. **IF SWALLOWED:** Rinse mouth. Do NOT induce vomiting. **IF ON SKIN:** Take off immediately all contaminated clothing. Rinse skin with water. – **IF IN EYES:** Rinse cautiously with water for several minutes. Remove contact lenses, if present and easy to do. Continue rinsing. – **IF EXPOSED OR YOU FEEL UNWELL:** Call a POISON CENTER or doctor.

For **sodium carbonate** and **calcium hydroxide**, note the “Hazardous substances and mixtures” information starting on p. 7.

EXPERIMENT 65

In a test tube, mix 2 spoonfuls of sodium carbonate with 2 spoonfuls of calcium hydroxide. Add 4–5 cm of water, close the test tube with the stopper, and shake! Then filter. The filtrate consists of diluted lye. Dilute again with five times the quantity of water and perform the “rub test” as in Experiment 47. Then wash your hands!



Sodium hydroxide draws humidity from the air and dissolves.

Sodium carbonate — Na_2CO_3 — and calcium hydroxide — $\text{Ca}(\text{OH})_2$ — react to each other as follows:

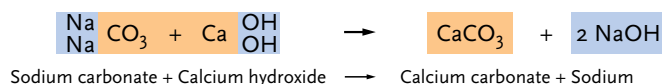

Hard-to-dissolve calcium carbonate is left behind on the filter, and the filtrate consists of lye — that is, of sodium hydroxide that has practically completely decomposed into sodium and hydroxide ions in water.

You can save the lye in a clean, labeled bottle, and then use it for experiments 68, 85, and 86; otherwise: **A2**, residue: **A3**

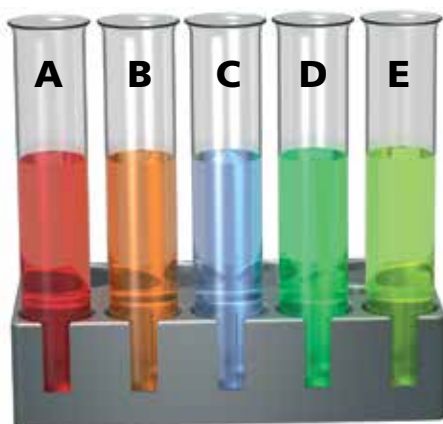

The color organ: anthocyanin solution with vinegar (A), ammonium chloride solution (B), water (C), baking soda solution (D), and limewater (E)

Color organ and pH



For **ammonium chloride**, note the “Hazardous substances and mixtures” information starting on p. 7.

EXPERIMENT 66

Additional material: Baking soda, permanent marker

Set 5 test tubes side-by-side in the test tube holder and label them from left to right with the letters A to E. To test tubes B, C, and D, add 5 cm of water, to test tube A add

5 cm of vinegar, and to test tube E add 5 cm of limewater. Then, add 1 spoonful of ammonium chloride to test tube B and 1 spoonful of baking soda (sodium hydrogen carbonate or sodium bicarbonate) to test tube D. Test tube C contains just water. To each test tube, add half a pipette of anthocyanin solution. **A1**

The anthocyanin solution doesn't just indicate “acidity” or “alkalinity,” it also lets you recognize different gradations of **acid strength**. To measure acid strength, the pH scale was introduced, which extends from 0 to 14 pH. A pH of 0 indicates “strongly acidic,” while a pH of 14 is “strongly alkaline.” A solution with a pH value of 0 contains a lot of H^+ ions and only very few OH^- ions, while one with a value of 14 has very few H^+ ions but a lot of OH^- ions. At a pH of 7, a solution contains the same amount of H^+ ions and OH^- ions; the solution has a neutral reaction.

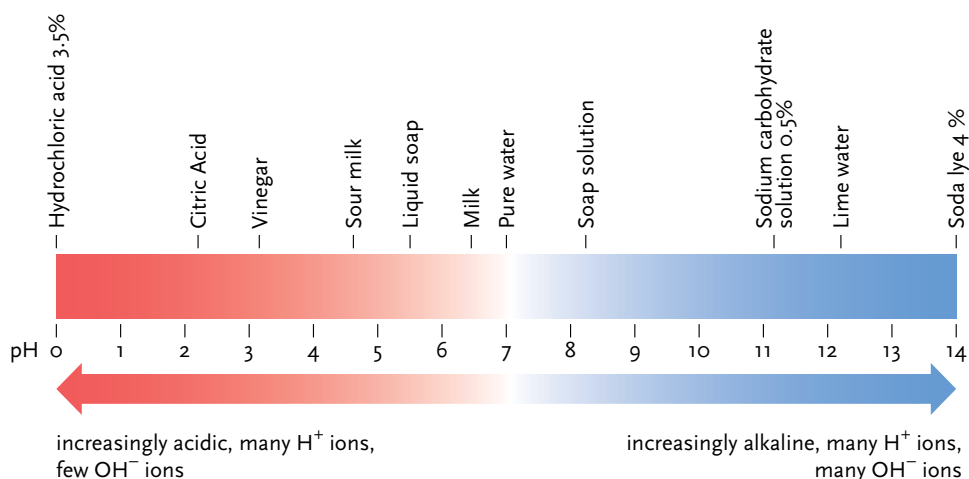

There are electronic pH meters and special indicators for measuring pH, which show much clearer color gradations than your homemade anthocyanin solution.

The art of titration

We have already covered neutralization in theory, but how can you ensure in practice that a certain quantity of acid or alkali is neutralized by an alkali or an acid? You can never quite reach the precise neutral point. But you can keep the excess of alkali or acid very low by using an indicator that reveals very small overshoots. The litmus solution is perfect for this. Even a single drop of acid will color it red. And a single drop of alkali will likewise suffice to make the color change from red to blue.



Vinegar has a pH of 3 — slightly acidic. Soap has a pH of 8 — slightly alkaline.



Electronic pH meter with digital display



For **calcium hydroxide** and **limewater**, note the “Hazardous substances and mixtures” information starting on p. 7, and for **soda lye** see the hazard and precautionary statements on p. 43.

EXPERIMENT 67

Fill a graduated beaker halfway with limewater and color it blue with 3–5 drops of litmus solution. Set the container on a sheet of white paper. Now add vinegar with the dropper pipette. Gently swirl the container each time you add some vinegar. You will briefly see red cloudiness at the spot where the litmus solution drips. When you swirl the beaker though, the solution turns a uniform blue again.



Question 12. How do you explain this phenomenon?

Just before you reach your goal, the solution will turn violet. Finally, one more drop of vinegar will be enough to make the red color persist. Now, the alkali has been completely neutralized by the acetic acid. **A1**

EXPERIMENT 68

Additional material: Fresh lemon

Now we'll turn things around and neutralize an acid with an alkali. To start, produce some lye by following the recipe in Experiment 65. Squeeze half a lemon and filter the juice. Measure 3 cm of lemon juice in a test tube and pour it into a graduated beaker. Fill the beaker halfway with water and add 3–5 drops of litmus solution. Set the beaker with the light red solution on white paper. Now, use the dropper pipette to drip your homemade lye into it. Each time some lye drips in, you will see blue clouds that give way to red when you swirl the container.



Question 13. Why does it make sense to use a backdrop of white paper for experiments such as the ones you just performed?

Just before you reach your goal, it will take a little longer for the color to disappear. Now you have to be alert — you have almost reached the point where a single drop of lye will be enough to turn the solution blue. **A1**

The neutralization experiments you just completed are no mere gimmick. If you have an alkali (or acid) of a known content — a so-called **standard solution** — you can calculate the quantity of acid (or alkali) contained in the solution under investigation based on the quantity of standard solution used. This activity is known as titrating, and the process is called **titration** (French *titre* = standard). In a professional lab, the addition of the standard solution is done with a burette, which is a long glass tube with a tap and measurement divisions, or completely automatically.

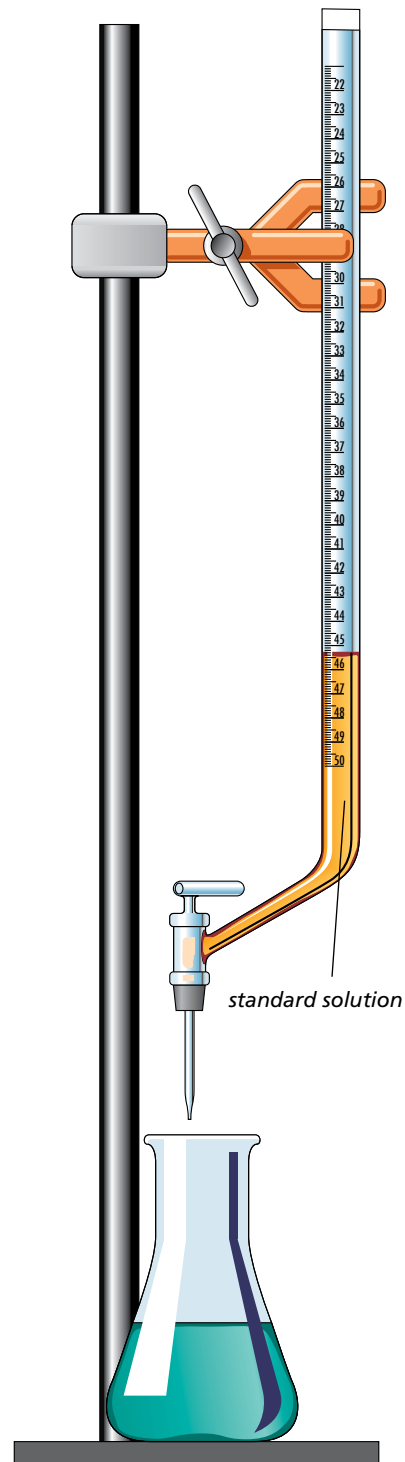

Titrating with burette and standard solution



Fully automatic titration (photo: Deutsche Metrohm, Germany)

6

The Greenhouse Gas from a Soda Bottle



Chimneys and exhaust pipes emit huge quantities of a gas that has a reputation as a climate killer.

Now you're going to learn about a gas that a lot of people are talking about — as a factor in climate change. In news media, you'll hear this gas called a greenhouse gas. But you may be surprised to hear that this is the same gas that provides the refreshing sparkle to soda, beer, and Champagne. We're talking about carbon dioxide. You may have heard about carbonic acid as well, which also has an important role to play in drinks as well as the environment.

Unlike hydrogen, oxygen, and nitrogen, carbon dioxide is not an element, but a compound.



Question 14. What clue lets you know this right away?

Carbon dioxide — also widely known as CO_2 — may be demonized as a problematic substance, but this isn't entirely fair. On the contrary, carbon dioxide, like water and oxygen, is among those things without which there would be no life. You will be learning why that is.

A sparkling pleasure

You will need some fresh sparkling water for the following experiments. If you have an appliance at home like the one shown on p. 47, you can make the sparkling water yourself.

When you open the bottle of sparkling water — whether from the supermarket or from your own appliance — it will hiss, and a lot of little gas bubbles will rise up from the liquid. The carbon dioxide in the bottle is under pressure, since elevated pressure allows more gas to be dissolved in the water. When you remove the pressure by opening the bottle, some of the dissolved gas escapes. You can use limewater, which you learned how to make in Experiment 63/64, as a test for carbon dioxide. Perhaps you made a bottle of limewater as we suggested. For the following experiments, you will be needing the sparkling water quite frequently. Set a bottle of it aside and mark it with a label: For chemical experiments only!



For **calcium hydroxide** and **limewater**, note the "Hazardous substances and mixtures" information starting on p. 7.

EXPERIMENT 69

Add 3–4 cm of limewater to a test tube and slowly (!) add sparkling water. You will get a white precipitate of calcium carbonate, which indicates carbon dioxide. You

have to add the sparkling water slowly because the precipitate dissolves in excess sparkling water (see Experiment 137). **A1**

Precipitate formations, especially colored ones, have an important role to play in tests for substances.





Sparkling water and dry ice

A lot of households today have an appliance that can turn ordinary drinking water into sparkling water in the blink of an eye. Instead of transporting sparkling water by the case, you just need to buy a gas cartridge every few weeks. The cartridge, which you insert into the rear of the appliance, contains carbon dioxide in liquid form. You can use high pressure to compress gases so powerfully that they turn into liquid, and thus take up only a fraction of the space they would otherwise need. When the valve is opened, the carbon dioxide turns to gas again and bubbles through the water in the bottle. In the process,

a portion of the gas dissolves and the sparkling water is ready. But you have to follow the instructions and only eject the gas into the firmly screwed-on bottle. If you introduced it into an open container (such as a glass of water), the water would spray all over the place.

When liquefied carbon dioxide suddenly evaporates, the evaporating gas draws so much energy from the still-liquid carbon dioxide that it cools down to -80° and freezes into carbon dioxide snow. Compressed carbon dioxide snow is used as dry ice. Dry ice is a highly effective freezing agent in the lab and in industry, such as in the transport of food products and other heat-sensitive goods.



EXPERIMENT 70

Usually, it's the gaseous carbon dioxide you have to test for, rather than carbon dioxide dissolved in water. Fill a test tube halfway with fresh sparkling water and close it with a stopper and angled tube.



Be careful when twisting the angled tube into the stopper! Note the information on pages 13/14. In case of injury: **First Aid 7** (inside front cover).

Would you prefer lugging cases of sparkling water bottles, or simply pushing a button?

Fill 3–4 cm of limewater into a second test tube. Take the first test tube in one hand and the second test tube in the other and immerse the free end of the angled tube in the limewater. Shake the test tube with the sparkling water a little. Gas bubbles will rise up through the limewater. **A1**

The test for carbon dioxide plays a role in a wide range of experiments. Would you like to know what's happening, chemically speaking? Here is the reaction equation:

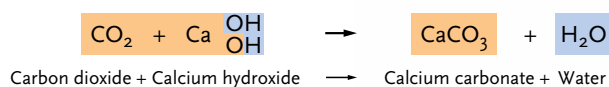

In addition to the calcium carbonate precipitate, water is produced, even though you can't see it in the liquid solution, of course.

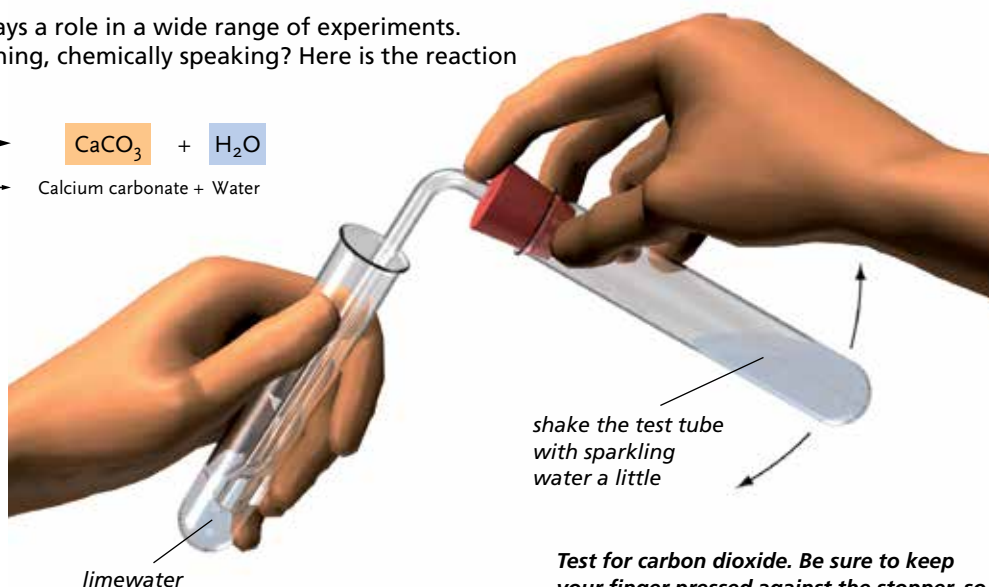

Test for carbon dioxide. Be sure to keep your finger pressed against the stopper, so it stays firmly in the test tube.



In wine cellar barrels, grape sugar is converted into alcohol and carbon dioxide — a centuries-old biotechnological process.

Side Notes

A gas with traction

Carbon dioxide is not poisonous, but its heaviness can allow it to displace the oxygen we need to breathe. It collects in low-lying, poorly ventilated areas — caves, fermentation cellars, or well shafts, for example, and in dells or basins out in the open. The Grotta del Cane near Naples, Italy, has long been famous for the carbon dioxide component of its air, which is 70% (compared to just 6% oxygen).

Workers who want to carry out repairs inside well shafts will first lower a burning candle into it to check if the air is “pure” — that is, if it contains enough oxygen. Carbon dioxide can also collect in wine cellars, since it is a by-product of the alcoholic fermentation of grape juice, so wineries have to be careful to provide adequate ventilation. At night, plants do their breathing — like humans and other animals, they take up oxygen and give off carbon dioxide. If you spend the night in a hollow when the air is still, you can encounter problems. If the air has a carbon dioxide content of just 8–10%, it can cause headaches, dizziness, and other complications.

Gas	Density (g/L)
Hydrogen	0.09
Nitrogen	1.25
Air	1.29
Oxygen	1.43
Carbon dioxide	1.98
Chlorine	3.21

Density, in grams per liter (g/L), of a few gases you will get to know in your experiments.

After the sparkle comes the acid



For calcium hydroxide and limewater, note the “Hazardous substances and mixtures” information starting on p. 7.

EXPERIMENT 71

Add 3 drops of limewater and 2 drops of litmus solution to 3 cm of water in a test tube. Spike the blue solution bit by bit with sparkling water until the color changes to red.

You will need to keep the solution for the next experiment.

Apparently, the sparkling water neutralized the alkaline calcium hydroxide solution.

EXPERIMENT 72

Place the boiling rod in the red solution and heat. The test tube contents will turn to violet and then blue. **A1**

Sparkling water contains an acid: carbonic acid. The carbon dioxide itself is not the acid, but it forms an acid along with the water:



In a solution in water, the carbonic acid decomposes into hydrogen ions, which are responsible for the acidic effect, and negatively-charged hydrogen carbonate and carbonate ions. In any case, only a small portion (0.1%) of the dissolved carbon dioxide is converted to carbonic acid with the water. In Experiment 72, excess carbon dioxide was driven out of the solution. In the process, the carbonic acid decomposed as well, which you could see in the return of a blue color.

A heavy gas

All gases are lightweights in comparison to solid substances. But not all gases are equally light.

EXPERIMENT 73

Add some limewater to a screw-top jar. Shake the bottle of sparkling water a little, open it, and hold it over the jar as shown in the illustration (cover the opening of the jar with your free hand).

Just don't let any sparkling water get into the limewater. Screw the lid onto the jar and shake. The cloudiness in the limewater is an indication that the carbon dioxide has apparently “sunk” into the glass. **A1**



EXPERIMENT 74

Additional material: Tealight candle, baking soda
Set a tealight candle in a graduated beaker and light it. Now, as a CO₂ source, instead of sparkling water you will be using your old friend baking soda (sodium hydrogen carbonate or sodium bicarbonate). Add 2 spoonfuls of baking soda to a medium-sized screw-top jar and add a dash of vinegar to it. Set the lid loosely on the jar. There will be some bubbling and hissing inside. "Pour" the gas, but not the liquid, into the beaker holding the tealight candle. In most cases, the candle light will go out. Sometimes though, the warmed air will pull the carbon dioxide up into the air. **A1**

EXPERIMENT 75

Additional material: Tealight candle, baking soda
Set the tealight candle on an old plate and light it. Now produce some carbon dioxide in a test tube from 1 spoonful of baking soda and a little vinegar. As soon as the foam subsides, move the test tube toward the flame from the side, as shown in the illustration. **A1**

The experiments make it clear: Carbon dioxide is "heavy." It has greater density than air (see the table on p. 48), so it collects at the bottom of containers and can be poured like a liquid. The last two experiments also show that carbon dioxide can put out a flame.



Carbon dioxide puts out the tealight candle flame.

A common product of combustion

Now, you will investigate what happens during a combustion process — and make a few interesting discoveries while you're at it.

EXPERIMENT 76

Additional material: Tealight candle
Hold a medium-sized screw-top jar open-end-downward above the tealight candle. Screw the lid onto the jar and turn it right-side-up. After a few seconds, remove the lid and add some limewater to the jar. Close the jar again and shake! **A1**

EXPERIMENT 77

Repeat the previous experiment, but this time hold the jar over the flame of your alcohol burner. **A1**



Question 15. How did the "heavy" carbon dioxide get into the jar?

Search for a product of combustion

EXPERIMENT 78

Additional material: Container with sand, wooden splint (wooden skewer)

Get a jar or can of sand ready. Add some limewater to a screw-top jar and lower a burning splint of wood into the jar for 3–4 seconds. Stick the burning splint into the sand to put it out and screw the lid onto the jar. Shake it! **A1**





Hard and shiny: diamonds



For **denatured alcohol** and **calcium hydroxide/limewater**, note the "Hazardous substances and mixtures" information starting on p. 7.

EXPERIMENT 79

Additional material: Container with sand, wooden splint
Ask an adult assistant to pour 1–2 cm of denatured alcohol into a test tube for you.

Add 8–10 drops of denatured alcohol to a screw-top jar, screw the lid on, and shake. Light the wooden splint (or wooden skewer — do not use a wooden match), open the jar, and lower the splint into it. The alcohol-air mixture will ignite, and you may see a blue flame. Stick the burning splint into the sand to put it out and quickly add some limewater to the jar. Close the jar and shake! **A1**

All the fuels we use contain the element carbon, which has bonded with the oxygen in the air to form carbon dioxide.

Carbon (symbol C), the main component of coal (Latin *carbo*), is an illustration of the fact that it isn't just compounds that can look quite different from the elements contained in them. One and the same element can appear in completely different-looking forms, or **allotropes** in technical terms. Hard, clear-as-glass diamonds and the soft, black graphite contained in a pencil lead consist of the same element — carbon. It wasn't until the 1980s that fullerene, a third allotrope of carbon, was discovered. The different appearance and properties of the different allotropes rest on different arrangements of their carbon atoms.

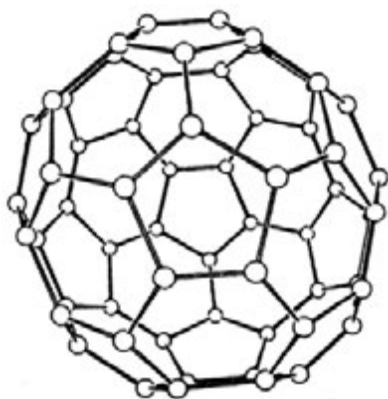
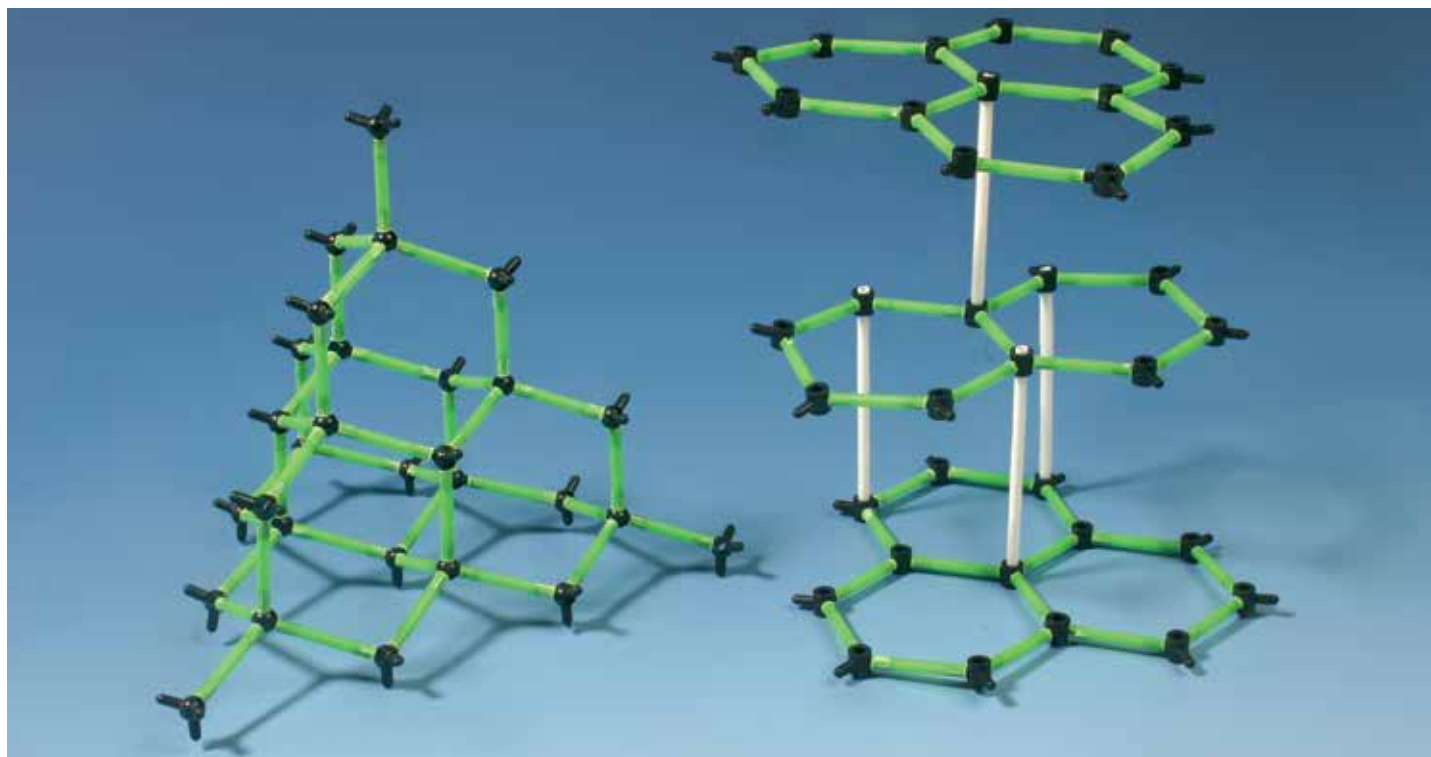

Black carbon or soot — a variant of graphite — arises during incomplete combustion of carbon-containing materials due to an inadequate oxygen supply.

EXPERIMENT 80

Additional material: Tealight candle, knife
Hold a shiny knife blade in the tealight candle flame. The metal will become covered with a layer of black soot.



Question 16. When candles burn, you sometimes encounter an "operating error" that can also tell you that the candle contains carbon. Do you know what we're referring to?

How much carbon dioxide can the air handle?

When wood, coal, or paraffin (candles) are burned, not to mention gasoline, diesel fuel, natural gas, and many other combustion materials, they produce carbon dioxide. Can the air handle it without problems?

EXPERIMENT 81

Add some limewater to a screw-top jar, screw on the lid, and shake! **A1**

Under normal circumstances, you will not get any cloudiness. If you do, you may have caught some "stale air."

EXPERIMENT 82

Additional material: Drinking straw

Fill a screw-top jar up to the rim with water, screw on the lid, and set it upside-down in the basin filled halfway with water. Remove the lid under the water. It's okay if you get a small bubble of air in the jar. Now, blow air into the jar with the straw until you are left with as little water as possible in it. Screw the lid back on under water, lift it out of the basin, and set it upright on the work surface. Remove the lid, add some limewater to the jar, close it again, and shake! **A1**

EXPERIMENT 83

Add 5 drops of litmus solution to 5 cm of water. Repeat the previous experiment, but instead of the limewater use the diluted litmus solution. The carbonic acid created

from the carbon dioxide will cause a color change to reddish purple. Demonstrate to yourself that the screw-top jar full of "normal" air won't bring about a color change with the litmus solution.

The air that you breathe — the air in Experiment 81, in other words — contains about 0.03% carbon dioxide. In exhaled air, the carbon dioxide portion is about 4%.



Combustion of wood, paraffin, and gasoline



Question 17. What do you conclude from this?

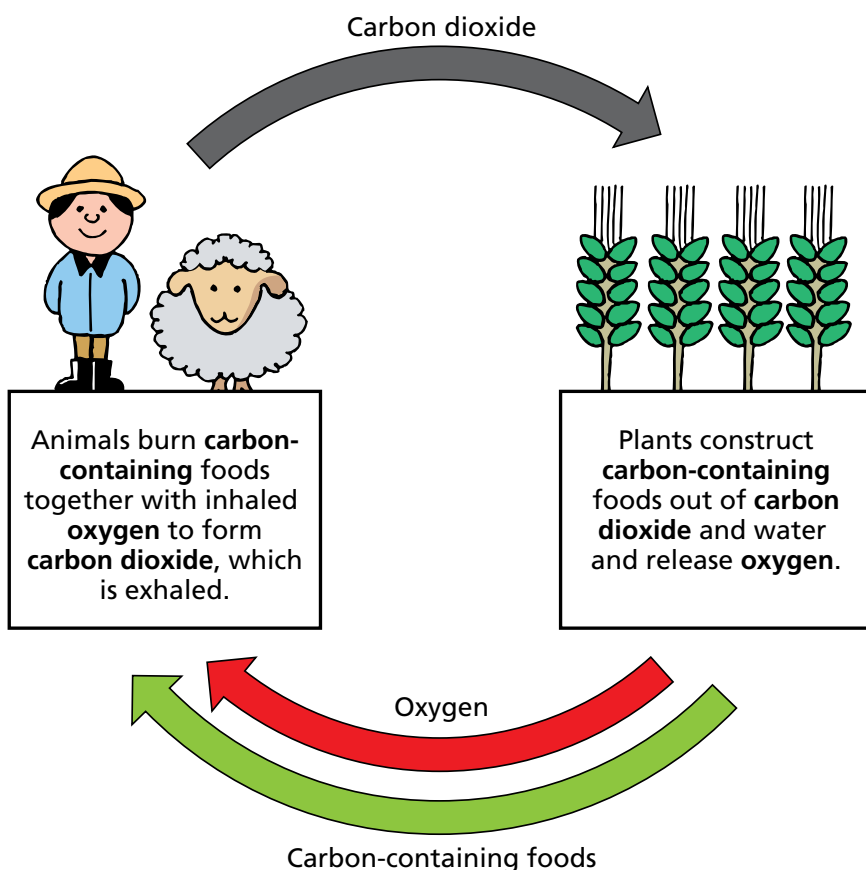

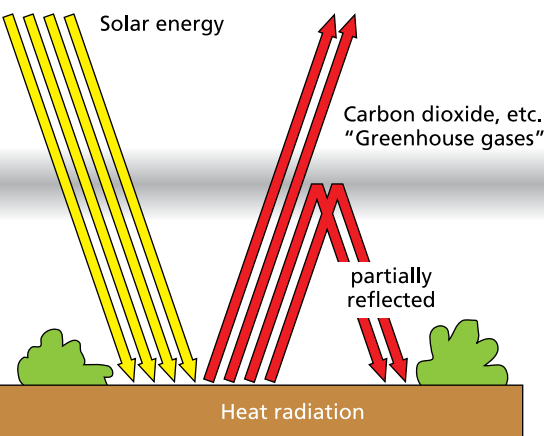

Carbon dioxide, water vapor, and a few other gases “swallow up” a portion of the heat radiating away from Earth’s surface. That helps ensure pleasant average temperatures in Earth’s atmosphere. An excess of carbon dioxide from increasing energy production can lead to a dangerous rise in temperature though.



Large expanses of rainforest are being chopped down.

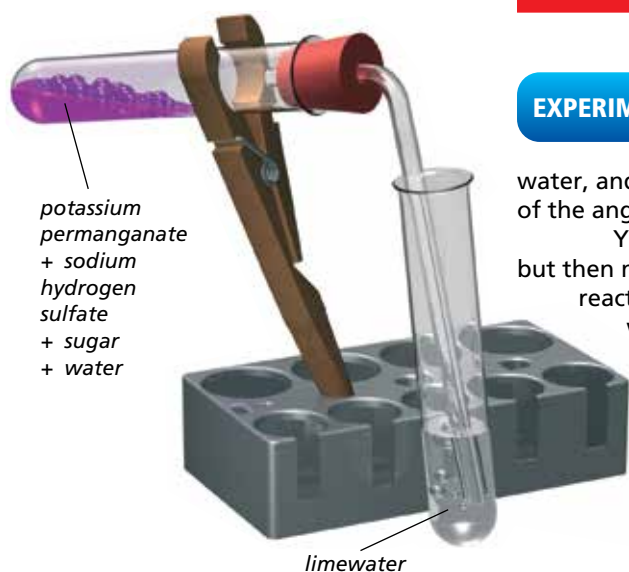

Simulation experiment with slow sugar combustion

TECHNOLOGY AND ENVIRONMENT



The issue with the greenhouse effect

Whether wood, peat, coal, petroleum, or the products obtained from them, such as gasoline and paraffin — they all produce carbon dioxide when burned.

Carbon dioxide, water vapor, and a few other gases allow the sun’s rays to pass through them on their way to Earth, but they also absorb a portion of the thermal radiation reflected back from Earth’s surface. That causes Earth’s atmosphere to warm up. Without this accumulation of heat, temperatures of just $-18\text{ }^{\circ}\text{C}$ ($0\text{ }^{\circ}\text{F}$) would make our planet pretty uncomfortable. Since these gases play more or less the same role as the glass roof of a greenhouse, people talk about the greenhouse effect.

The greenhouse effect only becomes a problem when carbon

dioxide emissions gain the upper hand due to our constantly-rising energy needs. In nature, there’s an admirable cycle that takes place, a balance between the production and consumption of carbon dioxide. Humans and animals “burn” the carbon contained in nutrients along with inhaled oxygen to produce carbon dioxide, which they exhale. Plants absorb carbon dioxide from the air and water from the ground and use the sun’s energy to produce nutrients along with the oxygen we need to breathe. But if too much fuel is heated, or the carbon dioxide-consuming rain forests are chopped down, the cycle is thrown out of balance. Carbon dioxide levels rise and it gets warmer and warmer. In the opinion of many scientists, this rise in temperature may in time melt the polar icecaps, which could result in widespread flooding.

Combustion without flames



For **sodium hydrogen sulfate**, **calcium hydroxide/limewater**, and **potassium permanganate**, note the “Hazardous substances and mixtures” information starting on p. 7.

Be careful when twisting the angled tube into the stopper. Follow the instructions on p. 12/13. In case of injury: **First Aid 7** (inside front cover).

EXPERIMENT 84

Measure 1 spoonful of sugar, 2 spoonfuls of sodium hydrogen sulfate, and 3 spoonfuls of potassium permanganate mixture into a test tube, add 3 cm of water, and assemble the experimental setup shown in the illustration. The free arm of the angled tube should be immersed in limewater.

You will see gas bubbles rising through the limewater, slowly at first but then more quickly, eliciting the familiar cloudiness. You will also observe the reaction mixture start to bubble a little. Carefully touch the test tube. Pretty warm, right? After it cools, fill the test tube with water: **A6**

This experiment is a simulation of metabolic processes taking place in the bodies of humans and animals. The sugar is the food, the oxygen from the potassium permanganate takes the place of oxygen inhaled from the air. The exhaled air, or the air coming out of the angled tube, contains carbon dioxide. And the heating of the reaction vessel illustrates the gain in energy from the “slow combustion” of nutrients.

The oceans as CO₂ storehouses

Scientists assume that there is about 50 times as much carbon dioxide stored in the ocean as in Earth's atmosphere. Some of the carbon dioxide is fairly firmly fixed, such as in sedimentary rocks. But a large portion is dissolved in the water. The following experiments will show what happens to the carbon dioxide when the water is heated.

To start with, prepare a few milliliters of lye according to the instructions in Experiment 65.



For **soda lye**, see hazard and precautionary statements on p. 43.



There are vast quantities of carbon dioxide stored in the sea.

EXPERIMENT 85

Fill a graduated beaker up to the 25-ml mark with no-longer-fresh sparkling water, add 5 drops of litmus solution, and lay a sheet of white paper under the beaker. Add your homemade lye drop by drop, keeping track of the number of drops it takes before the blue color sticks (swirl the beaker after each addition of lye). **A1**

EXPERIMENT 86

Have an adult help you with this experiment. Warm a cup of the same sparkling water in a small pot on the stove. Let the contents cool, measure off 25 ml again, and proceed as in the last experiment. **A1**

In the last experiment, just a few drops of lye were enough to neutralize any carbonic acid that was still present. Heating reverses the solubility of the carbon dioxide — the gas escapes into the air.

The same thing happens with the carbon dioxide dissolved in the oceans under conditions of global warming. A portion of the gas escapes into Earth's atmosphere and intensifies the greenhouse effect, which in turn heats up the oceans — a vicious circle.

But you have also seen that carbon dioxide is one of the gases essential to life. Without carbon dioxide, there would be no plants, and without plants there would be no animal life, and certainly no humans, who are the ones doing a lot of things to bring nature's carbon cycle out of balance.



Without carbon dioxide, there would be no plants or animals.



7

Sulfur Dioxide and Acid Rain

Sulfur and its combustion products

In Experiment 44, you burned sulfur to form **sulfur dioxide**. Now let's prepare a solution of the gas in water so that we can easily study its properties. Perform these experiments outside or by an open window. Ventilate well afterwards. Stick to the indicated quantities.



For **sulfur dioxide**, see hazard and precautionary statements on p. 34. For **sulfur** and **calcium hydroxide/limewater**, note the "Hazardous substances and mixtures" information starting on p. 7.

EXPERIMENT 87

Bend the double-headed measuring spoon again as shown in the illustration. Add some sulfur to the small rounded part of the spoon and heat it over the alcohol burner flame until the small blue flame appears. Quickly lower the spoon into a screw-top jar with a little water in it (the spoon must not dip into the water though) and set the lid loosely on top as shown. The glass fills up with a sharp-smelling, acrid gas. Quickly pull the spoon out, seal the jar with the lid and shake! Open the jar. The piercing odor has become weaker.

EXPERIMENT 88

Stain a strip of anthocyanin paper green with 1 drop of limewater, dry the strip off a little between pieces of paper towel and then test the solution in the jar using the green strip (add it drop by drop to the test paper). The green disappears and the strip shows a pale violet shimmer, which is typical for a weak acid. **A1**



For **sodium carbonate**, note the "Hazardous substances and mixtures" information starting on p. 7.

EXPERIMENT 89

To 1–2 pipettes of the solution from the jar, add 2–3 drops of litmus solution. Litmus also indicates a weak acid by the red-violet coloration. **A1**

With sulfur dioxide, just as with carbon dioxide, most of the gas is physically dissolved in the water. Only a small portion of the sulfur dioxide forms sulfurous acid (H_2SO_3) with the water:

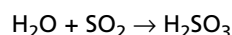

Like carbonic acid, sulfurous acid only exists in aqueous solution (as a solution in water) and cannot be isolated from the solution. Acids like sulfurous acid and carbonic acid, which only split off a fraction of the hydrogen in the form of hydrogen ions, are referred to as weak acids. In aqueous solution, strong acids like hydrochloric acid split off practically all of the hydrogen as hydrogen ions.



Burning sulfur



Minerals containing sulfur. Top: desert rose (gypsum with embedded grains of sand) and pyrite (iron sulfide); bottom: translucent gypsum crystals

Sulfur



Sulfur, one of the few non-metals that are solid at normal temperature, has been known since antiquity. In its elemental form, sulfur occurs as a yellow, crystalline substance as well as in numerous compounds, such as in the minerals pyrite, galena, chalcopyrite, barite and gypsum.

Sulfur compounds included in your experiment kit are copper sulfate and sodium hydrogen sulfate. But your equipment also contains elemental sulfur in the form of flowers of sulfur, or sublimed sulfur. This fine, yellow powder is formed when sulfur vapor is

cooled.

Sulfur forms crown-shaped molecules made up of 8 sulfur atoms (S_8 molecules), which rearrange themselves into long chains at 160 °C but break down again into small fragments — into two-atom molecules (S_2), among other things — when their boiling point (444 °C) is exceeded. When heated in contact with air, sulfur bonds at 260 °C with oxygen to form sulfur dioxide.

As a typical non-metal, sulfur is a poor conductor of heat and electricity. When rubbed together with a piece of leather, pieces of sulfur take on a negative charge.

Sulfur is common in animate (living) nature too. It is found in sulfur-containing amino acids (which are the building blocks

of protein), in enzymes, vitamins and bodily fluids. The human body contains 175 g of sulfur on average.

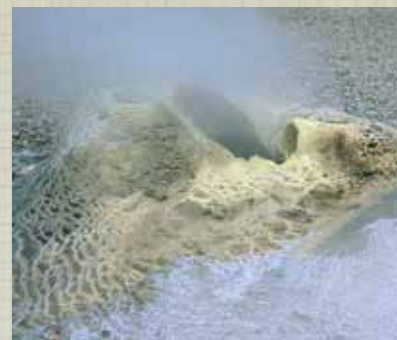

Sulfur-containing spring in Iceland

From sulfurous acid to sulfuric acid



For **sodium hydrogen sulfate** and **potassium permanganate**, note the “Hazardous substances and mixtures” information starting on p. 7.

EXPERIMENT 90

Dissolve a few specks of potassium permanganate mixture in a test tube with 4–5 cm of water and add 1 small spoonful of sodium hydrogen sulfate.

Ideally, prepare a solution of sulfurous acid according to the instructions given in Experiment 87 and add 1–2 pipettes full of the solution to the violet potassium permanganate solution. Shake it! The color disappears. **A1**

For a number of experiments, you will need a small bottle of iodine solution, which an adult will need to get for you from the pharmacy. The best thing to get is Betadine® solution. Iodine substitutes won't work. Iodine is a non-metal that is solid under normal conditions and, in nature, occurs only in compounds, such as in sea salts. It consists of shiny black flakes that are difficult to dissolve in water but dissolve readily in alcohols or special solvents. For your experiments, you will use an alcohol-free solution. Iodine gets its name from the violet color of iodine vapor (Greek *ioeides* = violet).



For **iodine**, note the “Hazardous substances and mixtures” information starting on p. 7.

EXPERIMENT 91

Add 1 drop of iodine solution to a test tube that is half-filled with water. The solution should now just look yellow. After you add the sulfurous acid, the solution

from the jar, the iodine solution turns colorless. **A1**

The reactions described in Experiments 90 and 91 can be used to test for sulfurous acid. But they're not specific, meaning that there are other substances that react in the same way with potassium permanganate and iodine.



Molecules of solid sulfur consist of 8 sulfur atoms (S_8). The top image shows a molecular model of spheres fused together (CPK model), while the bottom image shows a molecular model in which the atoms are spaced apart and joined by rods. This type of representation offers better clarity for larger molecules.



Iodine as a solution and in solid and gaseous (violet-colored) form

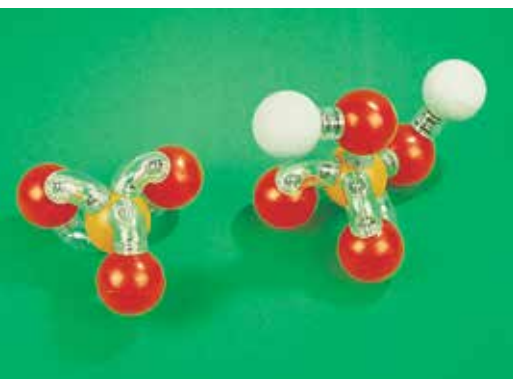

Molecular models of sulfur trioxide and sulfuric acid — a “hybrid” between CPK and ball-and-stick model that has gone a bit out of fashion

In the experiments you just performed, sulfurous acid became sulfuric acid. The sulfurous acid took on another oxygen atom.



Question 18. So what is the formula for sulfuric acid?

Sodium hydrogen sulfate — a sulfuric acid for hobby chemists

In Experiments 90 and 91, you prepared highly diluted sulfuric acid. Concentrated sulfuric acid is no joke. It is one of the most aggressive chemicals in the professional laboratory. So it’s understandable that it’s out of the question for hobby chemists. But your kit does contain a salt of sulfuric acid: **sodium hydrogen sulfate**. The name and the chemical formula make it clear that the compound contains hydrogen. As in an acid, this hydrogen can be split off in the form of hydrogen ions. An aqueous sodium hydrogen sulfate solution has an acidic reaction.

Sodium hydrogen sulfate is also classified as a “hazardous substance,” but it’s safer to handle than sulfuric acid.



Basic Knowledge

Oxidation and reduction

While burning metals (Ch. 4), you learned that when an element is combined with oxygen, it’s called **oxidation**. Oxidation also takes place when an oxygen-containing compound takes on additional oxygen, as in Experiments 90 and 91. When a substance takes up oxygen, another substance has to be there to give the oxygen off. In Experiment 90, the oxygen-rich potassium permanganate provided the additional oxygen atom. But you can also look at it the other way around: An oxygen atom was taken away from the potassium permanganate, which converted the violet potassium permanganate into a colorless compound. A reaction in which oxygen is removed from a substance is called **reduction**.

In modern chemistry — as it’s taught in school — oxidation and reduction are defined more fully, based on the electrical charge of the particles. Oxidation involves an increase in the charge (comparable to a rising thermometer), and reduction involves a decrease in the charge (like a drop in temperature). But that goes beyond the scope of this manual.



Industrial production of sulfuric acid (photo: Lurgi)



For **sodium hydrogen sulfate** and **sodium carbonate**, note the “Hazardous substances and mixtures” information starting on p. 7.

EXPERIMENT 92

In a test tube, dissolve 1 small spoonful of sodium hydrogen sulfate in 4–5 cm of water, and test the solution with blue litmus paper or anthocyanin paper. **A1**

EXPERIMENT 93

Additional material: Baking soda

Place 1 small spoonful of baking soda (sodium hydrogen carbonate or sodium bicarbonate) in a test tube and add sodium hydrogen sulfate solution to it. The fizzing is indicative of carbon dioxide being released, just like when other acids are added (see Experiment 74). **A1**

What's interesting is that solid sodium hydrogen sulfate can replace concentrated sulfuric acid in some cases: for example, when preparing hydrogen chloride (Experiments 97, 98, and 102) and during the oxidation of copper to form copper sulfate (Experiment 176), with sulfur dioxide being formed as a by-product.

Sulfur dioxide — an aggressive gas

Perform this experiment outside or near an open window. Ventilate well after the experiment. Keep to the indicated quantities.



For **sulfur dioxide**, see hazard and precautionary statements on p. 34. For **sulfur**, note the "Hazardous substances and mixtures" information starting on p. 7.



EXPERIMENT 94

Additional material: Colored flower petals

Add a few ml of water and colored flower petals to the screw-top jar. As you did in Experiment 87, burn a little sulfur in the small rounded part of the spoon and hang the spoon in the covered jar. As soon as the little blue flame has gone out, pull the double-headed measuring spoon out and seal the jar with the lid. Label it and put it someplace for one to two days where it can't be reached by young children or pets. **A1, A3**



Sulfur dioxide bleaches colorful blossoms.

EXPERIMENT 95

Additional material: 2 shiny iron nails

Repeat the previous experiment, but instead of the flower petals place the nails in the jar instead. Allow the well-sealed jar to stand again for one to two days. **A1, A3**



Question 19. What changes do you observe?

In Experiments 94 and 95, you've simulated the effects of "acid rain" on delicate blossoms and on harder materials.

Acid rain also leads to acidification of the soil and therefore damages plants, especially trees. The acids can be neutralized using lime, thus counteracting the acidification of the soil.



For **calcium hydroxide**, note the "Hazardous substances and mixtures" information starting on p. 7.

EXPERIMENT 96

Add some water to the screw-top jar and 1 pipette full of litmus solution. In the screw-top jar, burn sulfur in the small rounded part of the double-headed measuring spoon, close the jar, and shake.

The color of the indicator will turn red. Add 1 spoon tip of calcium hydroxide (as "lime") to it and shake it again. Observe how the color changes to blue. **A1**

Dispose of the sulfur residue on the spoon as indicated in Experiment 44.



Facility for the desulfurization of flue gas (photo: Lurgi)



One of the culprits of acid rain

Acid rain and forest dieback

Coal and petroleum always contain sulfur compounds. This is why considerable amounts of sulfur dioxide are released into the atmosphere by coal-burning power plants and private households (oil heaters). The sulfur dioxide dissolves in the air's humidity to form sulfurous acid, which is oxidized, in turn, by the oxygen in the air to form sulfuric acid. Both acids return to the ground as components of precipitation.

Many scientists think that acid rain is one of the main causes of forest dieback. The acid attacks the trees in various places, destroying the protective layer on the leaves (especially in coniferous trees) and penetrating into the

leaves and washing out important nutrients. The acid also causes nutritional deficiencies in the root region. Finally, the acid from the soil releases metal ions which attack the trees' fine roots, thus also impairing their ability to absorb nutrients.

Besides sulfur dioxide, nitrogen oxides and the acids formed from them are also responsible for acid rain. Nitrogen oxides come from the exhaust pipes of automobiles for the most part.

Flue gas desulfurization in power plants, changing out old small furnaces in private households, and the three-way catalytic converter for automobiles have led to a decrease of harmful exhausts and pollutants in some countries. But there is still a lot to do.

Acid rain is one of the main causes of forest dieback.



8

From Table Salt to Chlorine Chemistry

You already know that the table salt used in the kitchen isn't the only kind of salt, and that chemists use the term salt to refer to any substance that, in its solid state, forms crystalline structures made of positively and negatively charged ions. Nevertheless, it was table salt, which is composed of 96 to 99% sodium chloride (NaCl) depending on how it is extracted, that gave the entire group of substances their name.

The acid that comes from table salt

As you learned in Chapter 5, hydrochloric acid is an aqueous solution of the gas hydrogen chloride. You will now release some hydrogen chloride from table salt and dissolve it in water.

Perform this experiment outside or near an open window. Ventilate well after the experiment. Keep to the indicated quantities.



DANGER

Hydrogen chloride is toxic if inhaled and causes severe skin burns and eye damage. – Do not breathe gas. – IF INHALED: Remove victim to fresh air and keep at rest in a position comfortable for breathing. – IF IN EYES: Rinse cautiously with water for several minutes. Remove contact lenses, if present and easy to do. Continue rinsing. – Immediately call a POISON CENTER or doctor. For **sodium hydrogen sulfate**, note the "Hazardous substances and mixtures" information starting on p. 7.



Evaporator in which the brine is heated until the table salt crystallizes out (photo: Saline Bad Reichenhall, Germany).



What would smoked meat and cheese be without salt?

EXPERIMENT 97

In a dry test tube positioned with the opening tilted slightly down, heat 1 spoonful of table salt with 1 spoonful of sodium hydrogen sulfate. You will notice a sharp odor. Hold a moistened strip of blue litmus paper in the opening of the test tube. As soon as the strip turns red, stop heating. Wait until the test tube has cooled off and add some water to it. The residue will slowly dissolve. A1

Table salt — a luxury item?

PROFILE

"As if!" you'll say. It's one of the cheapest things at the supermarket. But that wasn't always the case. There was a time when table salt was more valuable than gold. Many a city has salt to thank for its name and its wealth. The precious commodity was transported from the producer to the consumer along salt roads all across Europe.

Different methods are used to obtain salt. In hot, dry regions, sea water — which contains about 27 g of salt per liter on average — is fed into shallow pools. The

water evaporates, leaving sea salt behind. The salt from ancient seas, which forms underground layers measuring up to 1,000 m thick, can also be mined. This is referred to as rock salt.

The table salt that is used for cooking is obtained by boiling brine (concentrated salt solution). The brine is obtained from rock with a high salt content that is dissolved in water, with the heavier rock settling to the bottom (as in Experiment 14).

Sodium chloride is essential for humans and animals. The sodium ions perform numerous tasks, participating in the propagation of nerve impulses and in muscle excitation. Human beings normally need 2 to 3 g of table salt each day, and up to 15 g when performing strenuous physical work.



Salt production from sea water (photo: Luiz Travira, Portugal)

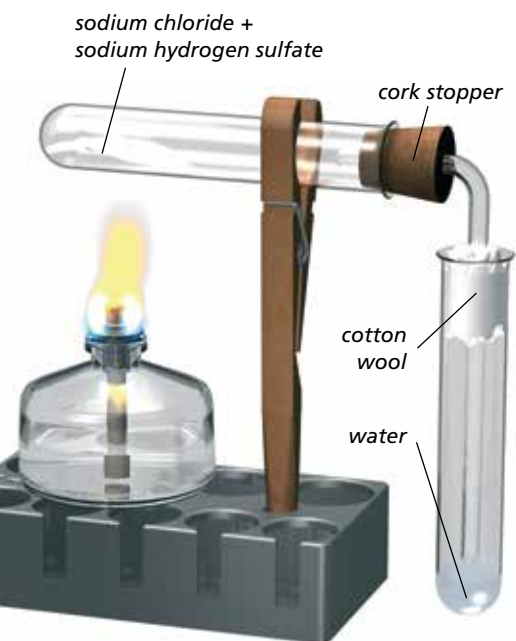

A small hydrochloric acid factory



For **sodium hydrogen sulfate** and **sodium carbonate**, note the “Hazardous substances and mixtures” information starting on p. 7. Be careful when twisting the angled tube into the stopper! Note the information on pages 13/14. In case of injury: **First Aid 7** (inside front cover).

EXPERIMENT 98

Additional material: Cotton wool

Add 4 spoonfuls of table salt and 4 spoonfuls of sodium hydrogen sulfate to a dry test tube and assemble the experimental setup shown to the left (here too, clamp the test tube so that its open end is tilted slightly downward). Be sure that the long arm of the angled tube is not immersed in the water, and loosely seal the test tube on the right with cotton wool. Heat the salt mixture. At the cooler end of the heated test tube, water droplets will begin to form. At the same time, a white fog will form which will soon fill the test tube on the right. **Dissolve the residue as in Experiment 97. A2**

EXPERIMENT 99

Test a few drops of the “water” in the test tube on the right using litmus solution and anthocyanin paper. It has an acid reaction. Keep the rest of the solution for the following experiments.

When a mixture of sodium chloride (table salt) and sodium hydrogen sulfate is heated, hydrogen chloride (HCl) is formed.

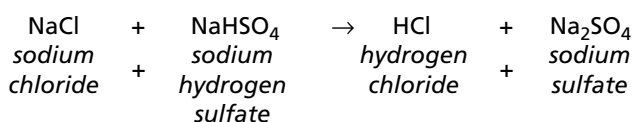

Hydrogen chloride is a gas and consists — as the name suggests — of the elements hydrogen and chlorine. When hydrogen chloride and water are brought together, the gas dissolves in the water and the HCl molecules break up into hydrogen and chloride ions: $\text{HCl} \rightarrow \text{H}^+ + \text{Cl}^-$. The aqueous solution is called hydrochloric acid. You’re already familiar with the theoretical background from Chapter 5. So the acid-reacting solution you prepared in Experiment 98 is nothing other than highly diluted hydrochloric acid.



Question 20. Why did the test paper turn red in Experiment 97?



In addition to other toxic gases like hydrogen sulfide and carbon monoxide, volcanoes spew out hydrogen chloride too.

EXPERIMENT 100

In a test tube, lace the rest of the hydrochloric acid you made with 1 small spoonful of sodium carbonate. The effervescence is, of course, caused by carbon dioxide being released. A drop of the solution on blue litmus paper won’t make it turn red — in other words, the solution is no longer able to have an acidic reaction. Save the solution for the next experiment.

EXPERIMENT 101

Heat the solution from Experiment 100 with the boiling rod in it until only a little bit is left (filling the rounded end of the test tube). Remove the boiling rod and carefully continue heating. A white crust forms: sodium chloride. You’ve evaporated a sodium chloride solution just like you did in Experiment 17.



Hydrochloric acid is also a component of gastric (stomach) juice, and aids digestion.

Fountain in a test tube

For the following experiment, which you should perform outside or near an open window, you will need to make some preparations. First twist the pointed glass tube into the rubber stopper with a hole as shown in the illustration.



For **hydrogen chloride**, see hazard and precautionary statements on p. 59. Be careful when twisting the glass tubes into the stopper! Note the information on pages 13/14. In case of injury: **First Aid 7** (inside front cover).

EXPERIMENT 102

Additional material: Cotton wool

Fill a small screw-top jar halfway with water and add 10 drops of litmus solution to it. Set up the same apparatus as in Experiment 98, using the cork stopper for the angled tube. This time, feed the resulting hydrogen chloride into a dry test tube that you seal loosely with a wad of cotton. As soon you notice the sharp-smelling vapors, discontinue heating. Residue: **A2**

Now seal the gas-filled test tube quick as a flash with the prepared stopper with the pointed glass tube and place it in the jar with the glass tube pointing downward. The liquid first rises in the glass tube and then suddenly hisses into the test tube. The color turns from blue to red. **A1**

Hydrogen chloride has an irrepressible affection for water: At room temperature, 1 L of water can dissolve about 450 L of hydrogen chloride. As you know from the previous experiment, this forms hydrochloric acid. In the fountain experiment, a little hydrogen chloride first dissolves, causing the external air pressure to predominate and press the water up the glass tube. As soon as the water exits the tip of the glass tube, all of the hydrogen chloride gas rapidly dissolves in the small amount of liquid. The air pressure pushes the water into the test tube, which now contains almost no gas. The resulting hydrochloric acid turns the litmus solution red.

The concentrated hydrochloric acid used in the laboratory contains about 38% hydrogen chloride, that is, 100 g of concentrated hydrochloric acid contains 38 g of hydrogen chloride.



Fountain in a test tube



Fountain experiment on a somewhat larger scale



Chlorine is the number-one disinfectant in swimming pools and water parks.



Question 21. What makes up the other 62 g of 100 g of concentrated hydrochloric acid?

Poison gas and disinfectant

Have no fear of the poison gas. You're only going to produce it in trace amounts that pose no risk to your health. As you've probably already guessed, the poison gas is chlorine. Chlorine is a heavy gas, weighing two and a half times as much as air. It gets its name from its greenish color (Greek *chloros* = yellow-green), but the color is practically invisible in the small quantities of gas we'll be dealing with.

You're now going to release a small quantity of chlorine from hydrochloric acid, prepared according to the instructions given in Experiment 98. Perform this experiment outside or near an open window. Ventilate well after the experiment. Keep to the indicated quantities.



Chlorine is toxic if inhaled, causes serious eye irritation and skin irritation and may cause respiratory irritation. – Do not breathe gas. – IF INHALED: Remove victim to fresh air and keep at rest in a position comfortable for breathing. Call a POISON CENTER or doctor. – IF IN EYES: Rinse cautiously with water for several minutes. Remove contact lenses, if present and easy to do. Continue rinsing. If eye irritation persists: Get medical attention.

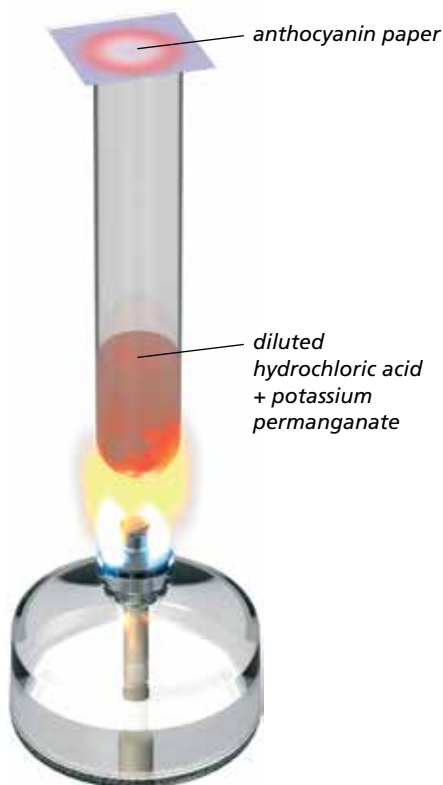

Releasing chlorine from hydrochloric acid



Vitamin C in tablet and powder form

Direct current breaks down the table salt solution. aluminum foil



! For **potassium permanganate** and **sodium carbonate**, note the "Hazardous substances and mixtures" information starting on p. 7.

EXPERIMENT 103 Pour 2 cm of the hydrochloric acid prepared as in Experiment 98 into a test tube and add 1 spoon tip of potassium permanganate mixture to it. Heat the mixture over the alcohol burner flame. The violet color of the potassium permanganate slowly changes to reddish brown. Carefully waft a bit of the vapor from the test tube toward your nose. You will notice a characteristic smell that you may know from the swimming pool. Place a moistened piece of blue litmus paper or anthocyanin paper into the opening of the test tube and heat it a bit more. A red spot will appear, and then gradually lose its color. **A7**

EXPERIMENT 104 Add 1 drop of vinegar or sodium carbonate solution to different parts of the faded test paper. Neither a red nor a blue nor a green color appears. The pigments have been destroyed. **A1, A3**

In Experiment 103, you released chlorine from hydrochloric acid, that is, from hydrogen chloride solution: The potassium permanganate converted the chloride ions into chlorine molecules. One way to detect chlorine is by its bleaching effect. But chlorine also converts colorless iodide solution into brown iodine. First you will need to prepare the iodide solution from iodine solution. In Experiment 91, you did that with sulfurous acid. It also works with vitamin C (ascorbic acid).

! For **iodine** and **calcium hydroxide/limewater**, note the "Hazardous substances and mixtures" information starting on p. 7.

EXPERIMENT 105 **Additional material:** Vitamin C (powder), iodine solution Dissolve 1 small spoonful of the powder in a test tube with 5 cm of water. To enough iodine solution to fill the rounded bottom of a test tube, add 5 cm of water. Add 1–2 drops of vitamin C solution to the yellowish-brown, diluted iodine solution. The solution turns clear as water. Soak a strip of filter paper with it. **A1**

EXPERIMENT 106 Release some chlorine again, as you did in Experiment 103, and hold the test strip (still moist) into the opening of the test tube. The strip turns brown! **A7, A3**

Vitamin C transformed iodine into colorless iodide. Chlorine transformed the colorless iodide back into brown iodine. In school, you'll learn that the iodine reduces to iodide, and the resulting iodide has been oxidized to form iodine. In other words, the test paper you prepared in Experiment 105 contains iodide, which is why it's also called iodide paper.

Electrical current breaks down table salt solution

Potassium permanganate isn't the only thing that can release chlorine from table salt. The current from a 9-volt battery does the trick too.

EXPERIMENT 107 **Additional material:** 9-volt square battery, aluminum foil Set up a graduated beaker as shown in the illustration and fill it up to the 75 ml mark with table salt solution. Make sure that the carbon electrode is connected to the positive terminal (to the red wire) of the battery.



As soon as the carbon electrode dips into the solution, this completes the electrical circuit and gas bubbles rise up at both terminals. You'll also notice the typical smell of chlorine. Hold a strip of blue litmus paper against the carbon electrode. The strip turns red in places but slowly fades at the spot where it is pressed against the electrode. **A1**

EXPERIMENT 108

Empty the graduated beaker, fill it with fresh salt solution and add 3–4 drops of litmus solution to it. Repeat the previous experiment. As soon as the electrical circuit is completed, the solution at the negative terminal (at the aluminum foil) turns a bluish color. **A1**



Question 22. What do you make of this?

EXPERIMENT 109

If you have a source of direct current but don't know which is the negative and which is the positive terminal, you can easily find out using the reaction we just performed. Soak red litmus paper with table salt solution, place the strip on a solid base and press the terminals of the wires onto the test paper a few millimeters apart from each other. A blue spot will form at the negative terminal. **A3**

Electrolysis — half-dry

Additional material: 9-volt square battery, aluminum foil

Set up the lid of a jar as shown in the illustration and connect it to the negative terminal of the battery. Soak a multi-ply piece of paper towel with table salt solution and place on the aluminum surface.

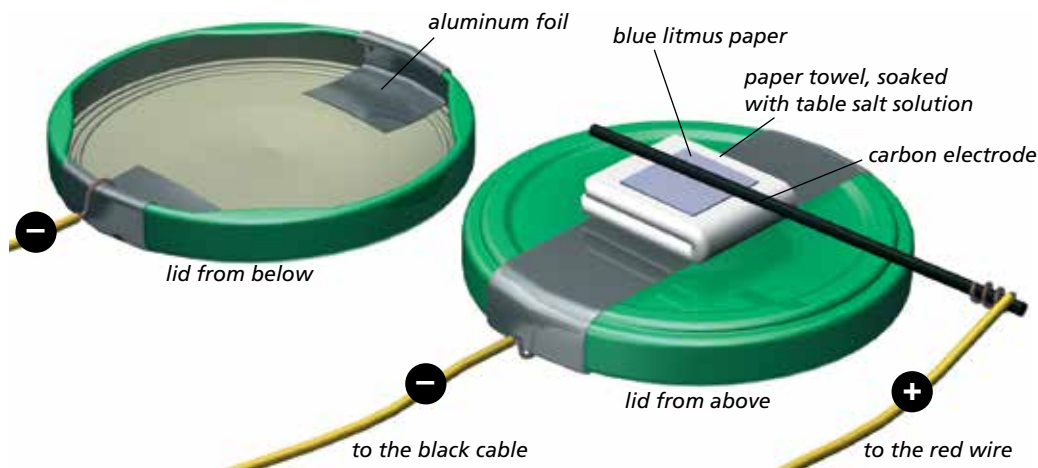

Electrolysis — half-dry

EXPERIMENT 110

Place a small piece of blue litmus paper onto the paper towel and press the carbon electrode connected to the positive terminal onto the test strip for about 20–30 seconds. When you lift up the electrode, you'll notice that the test strip has bleached out at the contact point, whereas it has turned red in places to the side of it. Add 1 drop of limewater to the faded spot. The contact point remains pale, but a blue color appears to the left and right. **A3**

Basic Knowledge

Migrants between two poles

You already know that salts are made up of positively charged metal ions and negatively charged acid residue ions. In a solid state, in the crystal, the ions are arranged in characteristic patterns. But once salts are dissolved in water, the crystals break apart and the ions swim around freely in the solution. If electrical current is run through the solution, the positively charged metal ions migrate to the negative pole (terminal) and the negatively charged acid residue ions migrate to the positive pole according to that age-old maxim — opposites attract. The migrating ions complete the electrical circuit, so they're the reason why salt solutions conduct electricity.

But what happens with ions once they've reached the oppositely charged pole? Simple: Either they're discharged and return to the elemental state (for example as a gas or metallic precipitate), or they remain in the solution if other ions, for example from the water being used as a solvent, can be discharged with less expended energy.

Table salt is made up of positively charged sodium ions (Na^+) and negatively charged chloride ions (Cl^-). During electrolysis, the chloride ions are discharged at the positive pole and escape as acrid, bleaching chlorine gas. At the negative pole, the sodium ions do not give off their positive charge — the released sodium would react immediately with the water. Instead, hydrogen ions (H^+) from the solvent (water, in this case) are discharged, which is why hydrogen gas escapes at the positive pole. The remaining hydroxide ions (OH^-) are what produce the alkaline reaction at the negative pole (and hence the blue color).

Inner workings of table salt electrolysis

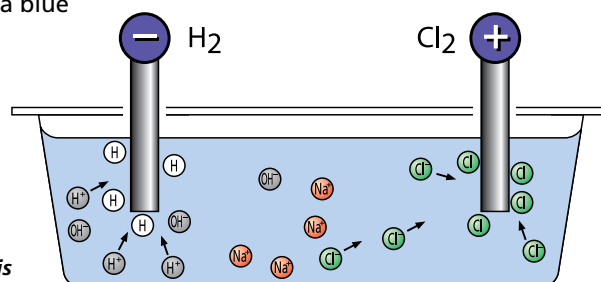



During chloralkali electrolysis, chlorine, hydrogen, and soda lye are produced (photo: Lurgi).



Electrolysis of a potassium iodide solution



TECHNOLOGY AND ENVIRONMENT



From limestone to lime mortar and back

The detection of carbon dioxide using lime water plays an important role in chemical investigations, since the gas — as you will soon see — is involved in a wide variety of processes. But by far the largest quantity of calcium hydroxide is used for quite another purpose: building houses.

In regions with abundant lime, limestone — calcium carbonate, chemically speaking — is broken down and often “burned” right then and there in tall shaft furnaces. The burning breaks the carbonate down into calcium oxide and carbon dioxide. The calcium oxide, “quicklime” or burnt lime, is “slaked” through the addition of water (as in the expression “to slake your thirst”). Slaking is the term used by those working in construction to refer to the conversion of the calcium oxide into calcium

hydroxide, which they therefore call slaked lime. In earlier times, the slaking was done exclusively at the construction site, but nowadays it takes place in the lime plants for the most part.

Using slaked lime, sand and water, the bricklayers then prepared the mortar that holds the building stones together as a binder. In this step, exactly the opposite happens as during the burning of the lime. The calcium hydroxide component of the mortar absorbs carbon dioxide from the air and hardens again into calcium carbonate, into limestone. This process is referred to as the “carbonation” or “hardening” of the mortar. Chemically speaking, the same reaction takes place as when detecting carbon dioxide using lime water: the formation of calcium carbonate — in one case as the hardening of the mortar and in the other case as the formation of a precipitate.



For **iodine**, note the “Hazardous substances and mixtures” information starting on p. 7.

EXPERIMENT 111

Additional material: Vitamin C (powder), iodine solution

Place a new piece of multi-ply paper towel on the aluminum surface from Experiment 110 and soak it with colorless iodide solution. You can prepare the iodide solution from iodine solution just as you did in Experiment 105, “decolorized” with vitamin C solution. Press the carbon electrode onto the paper. After only 10 seconds, it has left a blackish-brown impression in the paper. Do you think it might be a streak of charcoal?



Question 23. How can you show that the mark was made by iodine? **After the test: A3**

Just as electrical current releases chlorine from table salt solution (sodium chloride solution), it precipitates elemental iodine from iodide solution. Aha — this means that the positive terminal of an electrical current source behaves just like the **oxidizing agent** potassium permanganate: Negative chloride and iodide ions (charge -1) are converted into elements (charge ± 0) (see Basic Knowledge, p. 56). By the way, here you used a carbon electrode or, more precisely, a graphite electrode because graphite (see p. 50) conducts electrical current like a metal but doesn’t corrode during electrolysis. Metals — even semi-noble ones like copper — dissolve when they are connected to the positive pole of a source of current (see Experiments 165 and 180).

9

Baking Soda and Washing Soda: Two CO₂ Stockpiles

You already released carbon dioxide from washing soda (sodium carbonate in precise chemical terms) and baking soda (sodium hydrogen carbonate or sodium bicarbonate) in Chapter 6. Now you're going to get a chance to prove that the gas released really is carbon dioxide. In Experiments 74 and 75, we merely showed that carbon dioxide is "heavy" and puts out the candle flame.

But first a little info about the element sodium, which is contained in both washing soda and baking soda, in table salt and in a lot of other compounds as well. Sodium is a light metal. It is so light that it floats on water. Its density is 0.97 g/cm³, while that of water is 1 g/cm³, as you know. Sodium isn't quite as aggressive as its close relative potassium but does also strip water of its oxygen, turning it into lye in the process, while the hydrogen from the water escapes as a gas. Gaseous sodium (sodium vapor) emits an intense yellow light that is widely used in sodium vapor lamps to light streets.



Sodium vapor lamps provide plenty of lighting on pedestrian paths, even in gloomy weather.

Two similar compounds...



For **calcium hydroxide**, **limewater**, and **sodium carbonate**, note the "Hazardous substances and mixtures" information starting on p. 7. Be careful when twisting the angled tube into the stopper! Note the information on pages 13/14. In case of injury: **First Aid 7** (inside front cover).

EXPERIMENT 112

Add 3 cm of limewater to a test tube, and place the test tube in the test tube stand. Twist the angled tube into the rubber stopper

with a hole. Place 2 spoonfuls of sodium carbonate in a second test tube and add 2 cm of vinegar to it. Now you have to be quick, but don't get ahead of yourself! As soon as the foam column stops rising, seal the test tube with the stopper you prepared. Hold the test tube with the limewater in one hand and the test tube with all the hissing and bubbling in the other and lower the long arm of the angled tube into the tube with the limewater. Be sure that no foam or liquid gets into the limewater. Just as in Experiment 70, a white precipitate of calcium carbonate is formed. Set this precipitate aside, since you'll need it for Experiment 114. **A1**

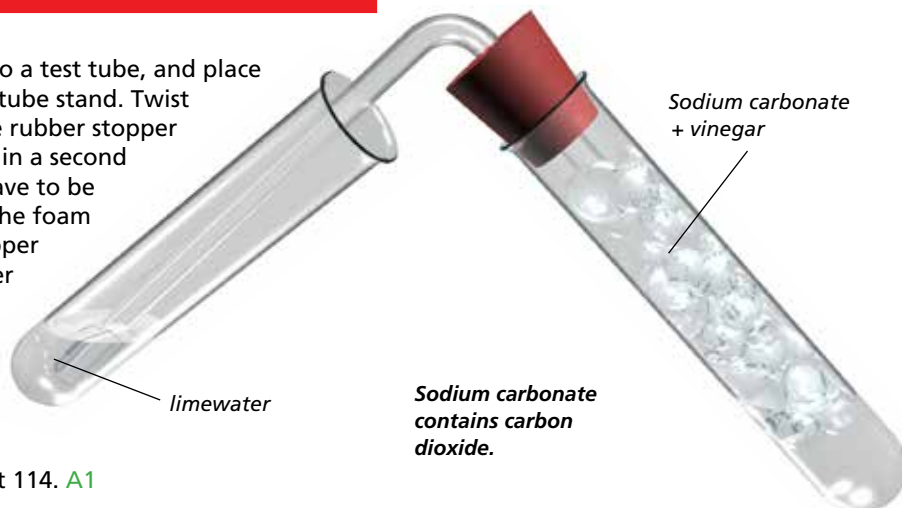

EXPERIMENT 113

Additional material: Baking soda

Repeat the experiment with baking soda. Set aside this precipitate as well.

EXPERIMENT 114

Add a little vinegar to the white precipitates from Experiments 112 and 113. They will dissolve. **A1**



Soda plays an important role in glass production.



Question 24. So what do you have to pay attention to when testing for CO₂ using limewater?

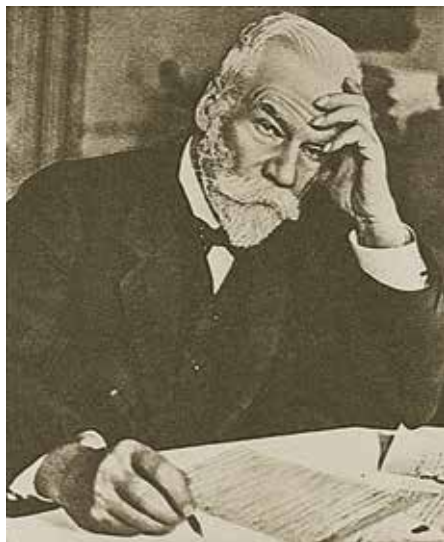

Ernest Solvay (1838–1922), chemist and industrialist, developed the process for producing soda that was named after him (photo: Deutsche Solvay-Werke, Germany).

TECHNOLOGY AND ENVIRONMENT



Soda production — back to nature?

In technical circles, soda (or “washing soda”) is the next-most important sodium compound after table salt. Half of the soda produced goes into glass manufacturing and a quarter to the production of other chemicals. It’s also used in the pulp, paper and washing detergent industries.

Up to about 160 years ago, the demand for soda was still met by burning plants containing salt. An early industrial process was developed in 1790 by Nicolas Leblanc (1742–1806). The big breakthrough for large-scale industrial production came in 1861 with the ammonia-soda process developed by Ernest Solvay (1838–1922).

In this process, sodium

bicarbonate is produced from table salt solution, carbon dioxide and ammonia (which you will become acquainted with in Chapter 11). The sodium bicarbonate is heated to convert it into water-free soda, just as you will do in Experiment 124. What’s so elegant about this process is that almost all of the by-products can be fed back into the production cycle, so that there is really only one “waste product,” calcium chloride, which can be further processed into gypsum (calcium sulfate).

Interestingly enough, the production of natural soda is making a comeback. Since 1985 in the U.S., pure soda has been produced almost exclusively from natural soda. It is obtained from a mineral containing washing soda and baking soda and having the composition $\text{Na}_2\text{CO}_3 \cdot \text{NaHCO}_3 \cdot \text{H}_2\text{O}$.



Steam-heated rotary furnace in which baking soda is converted into the final product — soda (photo: Deutsche Solvay-Werke).

Regardless of whether it’s sodium carbonate (Na_2CO_3), sodium hydrogen carbonate (NaHCO_3), or calcium carbonate (CaCO_3), acetic acid releases the weaker carbonic acid (H_2CO_3) from the salts, and the carbonic acid breaks down immediately into water and carbon dioxide.

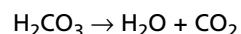

...with slight differences

So both compounds are CO_2 stockpiles from which you liberate the stored gas using acid. Carbonate and hydrogen carbonate are different in some respects though.

EXPERIMENT 115

To a test tube with 2 spoonfuls of sodium carbonate, add 4 cm of water, seal the tube with the stopper, and shake for a while. All of the sodium carbonate will dissolve. **A2**

EXPERIMENT 116

Additional material: Baking soda

Repeat the experiment with baking soda (sodium hydrogen carbonate or sodium bicarbonate). Even after quite a bit of shaking, some of it is still not dissolved. Sodium bicarbonate is less readily soluble in water than sodium carbonate. **A1**

EXPERIMENT 117

Additional material: Baking soda

Do you remember the "rub test" in Experiment 47? Put 1 cm of water in each of two test tubes. Add 1 spoonful of soda (sodium carbonate) to the first one and 1 spoonful of baking soda (sodium hydrogen carbonate or sodium bicarbonate) to the second. Rub the soda solution between your index finger and thumb, and do the same with the baking soda solution using the other hand. Wash your hands after the experiment! **A1**

Sodium bicarbonate only has a weakly alkaline reaction, which is why it fails the "rub test." But why does the sodium carbonate solution have an alkaline reaction, anyway? The thing is, unlike calcium hydroxide or sodium hydroxide, sodium carbonate (Na_2CO_3) doesn't contain any OH^- ions. Like many other salts, sodium carbonate reacts with the solvent water. This forms a weak lye (NaOH):

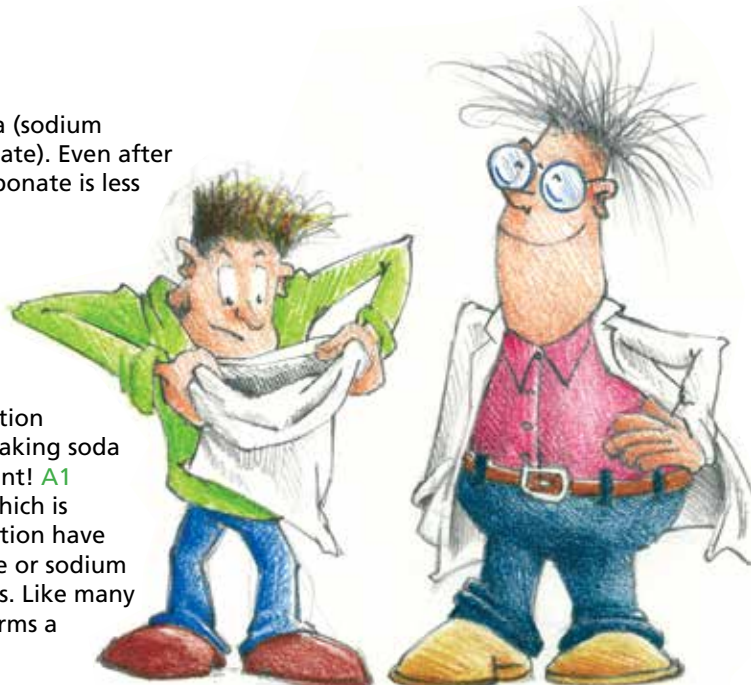
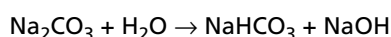

Question 25. A friend gives you a white powder to identify and tells you it's either finely ground table salt, washing soda, or baking soda. How can you find out what substance he or she gave you?

"I'm curious to see if you can figure out what's in there."

A gas gets swallowed up



For **sodium carbonate**, note the "Hazardous substances and mixtures" information starting on p. 7. Be careful when twisting the angled tube into the stopper! Note the information on pages 13/14. In case of injury: **First Aid 7** (inside front cover).

EXPERIMENT 118

Twist the pointed glass tube into the rubber stopper with a hole as shown in the illustration, and twist the short arm of the angled tube into the cork stopper with a hole.

Fill the basin with water. To a test tube (test tube 1), add 3 spoonfuls of sodium carbonate and 2 cm of water. Seal the test tube with the stopper with no hole and shake vigorously. Set the test tube aside in the test tube stand.

Fill 2 cm of vinegar into a second test tube (test tube 2) and add 2 spoonfuls of baking soda to it. When the foam stops rising, put the stopper with the angled tube on the test tube and feed the escaping carbon dioxide into test tube 1 (but don't let the angled tube dip into the solution).

As soon as the formation of gas noticeably subsides, set test tube 2 aside and place the rubber stopper with the pointed glass tube into test tube 1. Take the test tube in one hand, seal the opening of the glass tube with the index finger of your other hand, and shake vigorously.

Dip the tube sealed with your finger into the basin with the glass tube pointing downward as shown. Remove your finger, and water will shoot into the test tube! Seal the opening of the glass tube again under water with your index finger, lift the test tube out of the water, and shake it vigorously again. If you dip into the water again and release the opening of the glass tube, water will shoot into the test tube again!

Each time the test tube is shaken, the sodium carbonate swallows up a bit of the carbon dioxide that is fed in. This results in negative pressure in the test tube, so the outside air pressure pushes the water from the basin into the test tube. **A1**

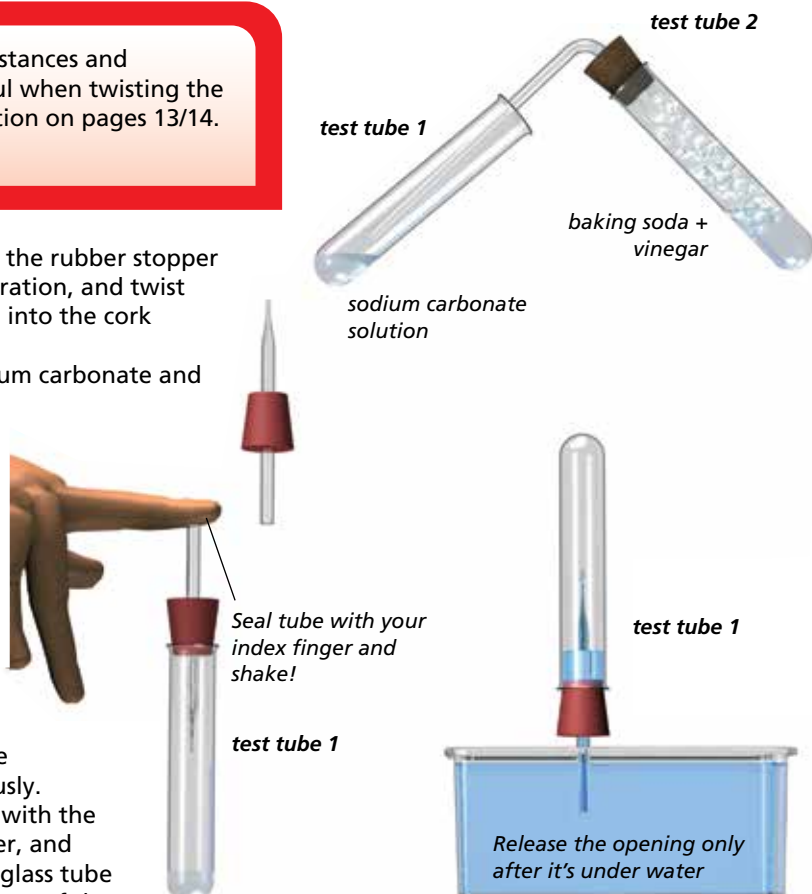

A gas is swallowed up.

Just give it another try if this somewhat complicated experiment doesn't work the first time.



Basic Knowledge

A reversible reaction

In Experiment 118, the sodium carbonate “swallowed up” the carbon dioxide by bonding with it. This formed sodium bicarbonate, your good old friend baking soda:



To get a better grasp of what’s going on here, let’s arrange the substances that are reacting with each other a little differently (HOH is of course H₂O, or water):

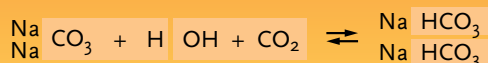

In Experiment 119, the same thing will happen at first. But since sodium bicarbonate turns litmus solution blue, this step in the reaction goes unnoticed.

Then the excess carbonic acid makes the color change to reddish-violet. When the solution is heated in Experiment

120, the acid is driven out (blue color), and then the sodium bicarbonate breaks down into the starting substances, indicated by the bottom arrow in the reaction equation. The direction of the chemical reaction depends mostly on pressure and temperature.



Even with the best ingredients and vigorous kneading, baking powder is still indispensable.



EXPERIMENT 119

In a test tube, dissolve 1 spoon tip of sodium carbonate in 3–4 cm of water and add 2 drops of litmus solution to it. Let carbon dioxide form in the test tube with the angled tube in it as in the previous experiment, and feed it into the blue sodium carbonate solution. Sure enough, after a few seconds, the blue switches to reddish-violet.

EXPERIMENT 120

Put the boiling rod into the clear solution and heat the test tube in the alcohol burner flame. The blue color slowly returns!

A closer look at baking powder

Ask your mom or dad to give you some baking powder in the name of science. Using a clean kitchen tablespoon, place some in a small cup. Remember, any baking powder that you touch with your double-headed measuring spoon and is left over has to be thrown out. Now let’s get cooking — not literally, of course.

EXPERIMENT 121

The procedure for this experiment is the same as for Experiment 112. Have a test tube with some limewater handy. To a second test tube, add 6–7 spoonfuls of baking powder and twice that amount of water. Seal the test tube with the stopper and angled tube and dip the long arm of the angled tube into the limewater. Soon you will see gas bubbling through the limewater, and the familiar cloudiness will form. No doubt about it: Baking powder produces carbon dioxide when water is added. **A1**

EXPERIMENT 122

In a small bowl, mix some flour and baking powder, add water to it, and stir well until a thick paste is formed. Place the bowl in a warm place (by a heater, if necessary) and watch what happens. It should rise noticeably. **A3**

As soon as the baking powder comes into contact with the moist dough, carbon dioxide is produced as in the previous experiment, and this makes the dough rise. Substances and mixtures that do this are called leavening agents (Latin *levare* = to raise).



For **sodium carbonate** and **calcium hydroxide/limewater**, note the “Hazardous substances and mixtures” information starting on p. 7.

EXPERIMENT 123

To a half test tube of water, add 1 spoon tip of sodium carbonate and 3 drops of litmus solution. Now add 2–3 spoonfuls of baking powder to it and shake. Baking powder must contain acid-reacting substances, because the blue solution turns reddish-violet. **A1**

When it comes into contact with the dough, baking powder releases carbon dioxide, which makes the dough light and fluffy. The carbon dioxide is formed from baking soda and acid-reacting substances, the main component of baking powder, as soon as they come into contact with water. Now you also understand why baking powder has to be kept dry. Since air always contains some moisture, flour or other substances are added to baking powder to bind the moisture.

When it gets too hot for baking soda to handle

There's another way to get baking soda to release carbon dioxide. Let's do a simulation experiment to see how.



Be careful when twisting the angled tube into the stopper! Note the information on pages 13/14. In case of injury: **First Aid 7** (inside front cover).

EXPERIMENT 124

Add 2–3 spoonfuls of baking soda to a dry test tube and assemble the experimental setup as shown (clamp the test tube so that it is tilted with its opening tilted slightly downward). The long arm of the angled tube dips into a test tube with a little limewater in it. Heat the baking soda. It won't be long before you have some lively gas production going on. The cloudiness of the limewater is a sign of carbon dioxide. At the same time, you will probably notice that some liquid droplets are condensing near the opening of the test tube. When the production of gas subsides, turn the heated test tube around so that the angled tube is no longer dipping into the limewater.

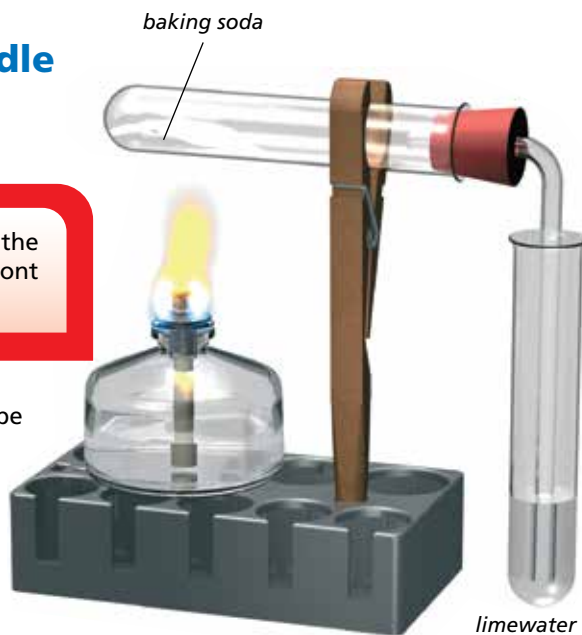

Thermal decomposition of baking soda



Question 26. Do you remember why the angled tube should no longer dip into the water after the flame is put out?

EXPERIMENT 125

Additional material: *Wooden skewer*

Once the test tube has cooled off enough that you can touch it, use the skewer to poke out some of the residue left in the test tube. Dissolve 1 spoonful of it in 1 cm of water and perform the "rub test." The baking soda has apparently turned into washing soda. **A2**

Surely you've noticed already. In Experiment 124, the reverse reaction described in the Basic Knowledge section (p. 68) took place, only this time you broke down the solid baking soda and the decomposition products sodium carbonate, carbon dioxide, and water (the liquid droplets) were identifiable. Baking soda used to be used for baking. But since the sodium carbonate that was produced gave the baked goods an unpleasant, soapy aftertaste, pure baking soda isn't used much as a leavening agent anymore; rather, as you found out, it's mixed with acidic substances like tartaric acid, citric acid, or acidic phosphates.

EXPERIMENT 126

Okay, now let's have a crack at the thermal decomposition of baking powder. The procedure is similar

to that in Experiment 124. But don't pour the baking powder directly into the test tube — put it in a little "boat" made of aluminum foil. Then push the little boat into the test tube and apply heat. You'll notice that carbon dioxide is being produced again. The contents of the boat will turn a brown to black color. At the same time, there will be a smell of burning. When baking powder is heated, the flour added to bind the humidity in the air breaks down. You used the aluminum boat to hold the baking powder, of course, because that kind of charred residue is hard or impossible to remove from glass. Boat: **A3**

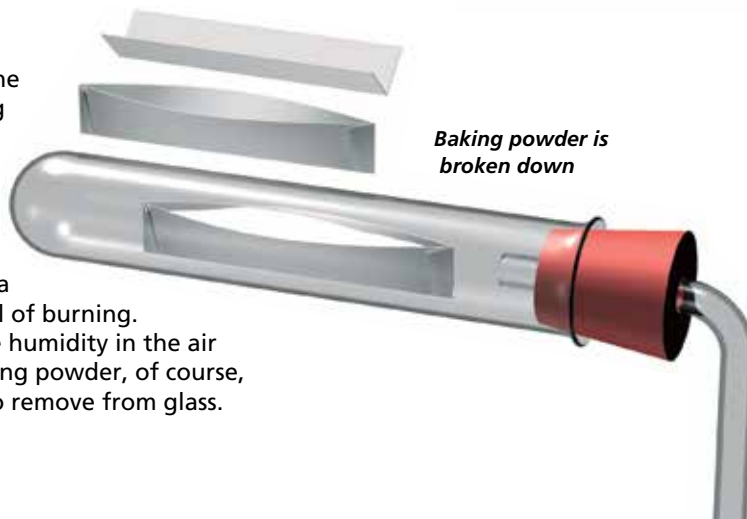

Device for preparing bubbling drinks called a "Liebig's jug."
From: *Stöckhardt, The School of Chemistry (1863).*



Side Notes

Soda or baking soda — that is the question

As carbonic acid salts, soda (sodium carbonate) and baking soda (sodium hydrogen carbonate or sodium bicarbonate) are closely related to each other. Their similar names can lead to confusion; they both have “soda” in their names because of the sodium they contain. To make matters more confusing, the two substances can often be found joined or mixed together in nature and are referred to in that state as *natron*.

The ancient Egyptians used *natron* from natural deposits in dry lake beds as a cleaning product. When blended to form soap, it acted as a water softener and cut through grease. *Natron* was also the primary ingredient used for embalming mummies. The word “*natron*” comes from the Arabic word *natrum* and can be traced to the much older word Ancient Egyptian word *netet*, which refers to the alkaline-reacting substance that they obtained from the soda deposits or from plant ash. Plant ash isn't really soda, but the similar compound potassium carbonate, otherwise known as potash (which you might recall from Chapter 5). They're so similar, in fact, that until 1750, there was no way to distinguish soda from potash.

The confusion around the names has led to the coining of some words that are technically incorrect. Soda water, for example, is actually nothing more than carbonated water. Before the invention of mineral water appliances containing cartridges of liquid carbon dioxide (Chapter 6), thick-walled stoneware bottles were used as containers for producing carbon dioxide from tartaric acid and baking soda (not soda!), and the water in the bottle was compressed so that it would absorb the carbonation. But these days, when you want to grab a carbonated soft drink, saying “soda” for short will likely prevent more misunderstandings than it causes.

Ghostly bubbles from a bag

Do you know those colorful packets with effervescent powder that you can take along on hikes in order to prepare a refreshing fizzy drink with clear spring water? Get yourself one or two packets of it. Of course, you can also use effervescent tablets, such as fizzing vitamin tablets — just crush them into a powder.

EXPERIMENT 127

Test a small amount of effervescent powder for acidic substances as in Experiment 123. **A1**

EXPERIMENT 128

Place the rest of the effervescent powder in a test tube, fill the tube halfway up with water and feed the escaping gas into limewater as in Experiment 112. The cloudiness tells you that the gas is carbon dioxide. That makes sense, because that's what gives mineral waters their refreshing zing. **A1**

Chemically speaking, there's not much of a difference between baking powder and effervescent powder. Both contain baking soda and solid acids, which is why carbon dioxide makes its effervescing, hissing escape when water is added to them.



Recipes

If it sounds like fun to you to make an effervescent powder yourself, use baking soda and citric acid from new unopened packets, and not the chemicals from this kit. You shouldn't use substances that have already been used for previous experiments, since they might have come into contact with other chemicals. Work in the kitchen with kitchenware and utensils.

EXPERIMENT 129

In a clean drinking glass, mix one-half teaspoon each of baking soda and citric acid with 1 teaspoon of sugar and fill the glass up with water. You can drink this homemade soda pop. Well, how does it taste?

EXPERIMENT 130

Instead of sugar, you can use fruit syrup for sweetening; then you'll have a fizzy drink with pizzazz and a good taste. Pour 1–2 cm of fruit syrup into a drinking glass, fill the glass with water and stir well. Now you pour this diluted syrup into a drinking glass with a mixture of one-half teaspoon each of baking soda and citric acid. Homemade soda pop — the hit of your next birthday party!

10

Quicklime and Plaster: Not just for Building

When you hear someone talk about metal, you might first think about iron and copper, lead and aluminum, silver and gold, maybe zinc and tin, but probably not light metals like magnesium and calcium. There's a reason for that. In everyday life, you never come face-to-face with light metals such as magnesium and calcium, and certainly not sodium or potassium either. These metals are always looking to connect up with something else, and they exist almost exclusively in compounds. For example, when exposed to air calcium combines with oxygen to form calcium oxide, a white powder also known as quicklime or burnt lime. The name comes from the fact that the compound is obtained by "burning" (heating) calcium carbonate. If you add a precise quantity of water to burnt lime, you get your old friend calcium hydroxide. Construction workers call this addition of water slaking, so they also call calcium hydroxide slaked lime.

Why mortar gets hard



For **calcium hydroxide** and **limewater**, note the "Hazardous substances and mixtures" information starting on p. 7.

EXPERIMENT 131

Stir together 2–3 spoonfuls of calcium hydroxide with a little water, so you get a spreadable paste. Shape the paste into a few little balls (use protective gloves!) and let them sit exposed to the air for several days. They will turn hard.

The hardening of mortar is due to the fact that calcium hydroxide takes carbon dioxide from the air and turns into calcium carbonate (CaCO_3). In the process, the mortar becomes so hard that it can join rocks together or stick to walls as plaster. As they say: "The mortar has set." Unlike in our simulation experiment, a bricklayer will add various quantities of sand to his slaked lime.

By the way, the same process takes place in our test for carbon dioxide with limewater as when the mortar hardens: calcium hydroxide becomes converted into calcium carbonate by taking up carbon dioxide. The cloudiness that occurs in the carbon dioxide test is — as you learned in Chapter 6 — none other than a finely dispersed calcium carbonate.

EXPERIMENT 132

Pour some vinegar over a few of the balls inside a test tube. Gas bubbles will form. You can accelerate the gas production by warming the test tube. Guide the gas into limewater as in Experiment 112. The cloudiness indicates that the gas is carbon dioxide. The carbon dioxide can only have come from the balls. [A1](#), [A3](#)

You have used the acid to release the carbon dioxide that was taken up in the setting of the balls of mortar.

Lime mortar is used for building and plastering walls. To create the particularly hard construction material known as concrete, you need **cement**, which you make by heating limestone and clay (aluminum-, silicon-, and iron-containing compounds) in large rotary kilns. To harden, cement and concrete don't require any carbon dioxide, which means that these building materials can also be used under water, such as in the construction of bridge pylons.

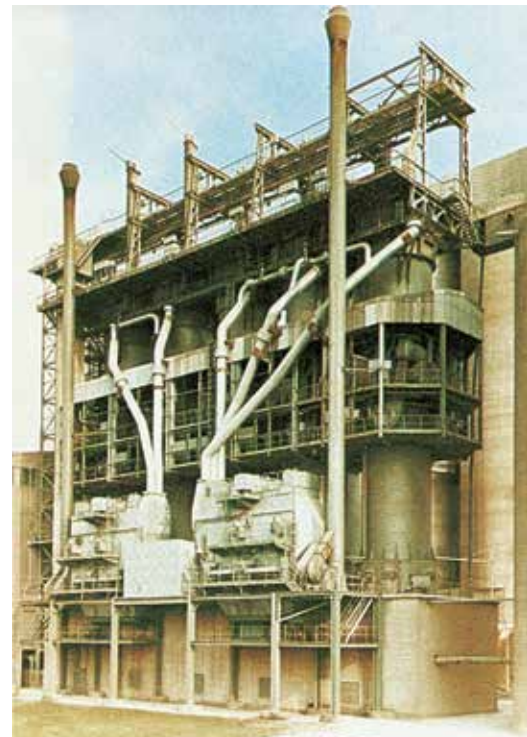

Furnaces in which burnt lime is made from limestone (photo: Dyckerhoff factory).



Two faces of calcium carbonate: mortar and the CO_2 detector



Insoluble and soluble calcium compounds

In nature, calcium carbonate appears in forms other than the limestone that is processed into burnt lime, slaked lime, or cement. The precious building material known as marble also consists of calcium carbonate, along with other mineral impurities. In living nature, calcium carbonate is found in egg shells and snail shells.

Calcium carbonate, calcium oxide, and calcium hydroxide are practically insoluble in water, or only partially so. However, these compounds are easy to dissolve in various acids, such as acetic acid.

EXPERIMENT 133

Additional material: Chicken egg (dispose of following the experiment)

Dab the egg with 1–2 drops of vinegar. Watch carefully: Tiny bubbles of gas will rise up in the vinegar drop. Just as in the last experiment, the vinegar is releasing carbon dioxide from the calcium carbonate in the egg shell.



For **calcium hydroxide**, **limewater**, and **sodium carbonate**, note the “Hazardous substances and mixtures” information starting on p. 7.

Side Notes

The dissolved column of marble

If someone gave you the task of dissolving a 10-meter-high marble column, you'd probably be at a complete loss. In fact, it wouldn't be so hard. All you'd need is a huge amount of acid and a gigantic container. Then you'd be able to get to work, because marble is nothing other than calcium carbonate.

To dissolve a 10-meter-high column of marble with a diameter of 80 cm, you would need around 22,000 liters of concentrated hydrochloric acid — about the quantity a special railroad container car could hold. The carbon dioxide that would be produced in the process would fill a cube with sides about 15 meters in length. This example clearly shows that carbon atoms are packed much more tightly in marble than they are in carbon dioxide.

EXPERIMENT 134

In a closed test tube (thumb over the stopper!), shake 1 spoonful of calcium hydroxide with 5 cm of vinegar. The contents of the test tube will gradually turn clear. Shake again and filter. You will need the filtrate for the next experiment.

The filtrate contains soluble calcium acetate, which is a compound of calcium and acetic acid (Latin *acidum aceticum*).



Question 27. You have already reacted acids with alkalis. Which experiments are we thinking of? You learned about a special type of reaction in them. What was the name of it?

EXPERIMENT 135

Dissolve 3 spoonfuls of sodium carbonate in 4 cm of water and add the solution to 2 cm of the filtrate from Experiment 134. A thick, white precipitate will separate out: calcium carbonate.



Earlier, you used the calcium carbonate precipitate as a test for CO₂, with limewater as the testing agent. This time, the precipitate has indicated a soluble calcium compound; the testing agent was the carbon dioxide bonded with the sodium carbonate. **A3**

How do mineral deposits get into the tea kettle?

You may have noticed (depending on the water quality where you live) that a yellowish-gray coating will develop in the tea kettle after a while — called limescale. How does it get into the kettle? To answer this question, you will first have to test your tap water.

EXPERIMENT 136

In a test tube mounted at a tilt, heat 1 cm of tap water until the water in the lower part of the test tube has evaporated. Use a rolled-up paper towel sheet to remove the coating of water in the upper part of the test tube before extinguishing the burner flame, without touching the glass in the process.

After it has cooled, take a look at the test tube. The white haze is none other than a “breath of limescale.” You will be able to see the limescale buildup more clearly in Experiment 138.



EXPERIMENT 137

In a test tube, carefully spike 5 cm of limewater with some sparkling water. You will get the now-familiar white precipitate of calcium carbonate. Add some more sparkling water to the test tube. The precipitate will disappear.



Question 28. How can you explain the disappearance of the precipitate?

TECHNOLOGY AND ENVIRONMENT



Hard water?

The precipitation falling to Earth always contains some carbon dioxide and, therefore, carbonic acid too. The carbonic acid-containing water dissolves limestone on its way through the earth, that is, it converts insoluble calcium carbonate into soluble calcium hydrogen carbonate (as you did in Experiment 137). In addition to the calcium hydrogen carbonate, the water contains other soluble calcium and magnesium salts. These materials are responsible for the hardness of water.

The hardness of drinking water varies according to the region it comes from. Water will be hard in calcium-rich regions, such as in a belt extending from Kansas through Texas to Southern California. Water will be soft where it runs through hard-to-dissolve rocks, or in rain-rich regions, such as the Pacific Northwest, New England, and the South. Water hardness is commonly measured in millimoles per liter (mmol/L) or milligrams per liter (mg/L). The table identifies the ranges for the four water categories of "soft," "moderate," "hard," and "very hard." Try learning about the water hardness in your area.

Hardness range	mmol/L*	mg/L
soft	0–1.3	0–52
moderate	1.3–2.5	52–100
hard	2.5–3.8	100–152
very hard	> 3.8	> 152

*1 mmol of calcium corresponds to 40 mg (milligrams) of calcium

Hard water causes problems when it is heated, because then — as you saw in Experiment 138 — the insoluble calcium carbonate precipitates out again, and it can accumulate in tea kettles, water pipes, water heaters, dishwashers, and washing machines. To prevent energy losses and damage to the machines, the water has to be softened. You will learn more about this along with the "hard water and soap" topic in Chapter 17.

Elsewhere, a decomposition of the hardness-inducing calcium hydrogen carbonate also occurs in stalactite caves. The insoluble calcium carbonate separates out from the dripping water and forms the building material for stalactites and stalagmites. The former grow down from the ceiling, while the latter grow up from the floor.

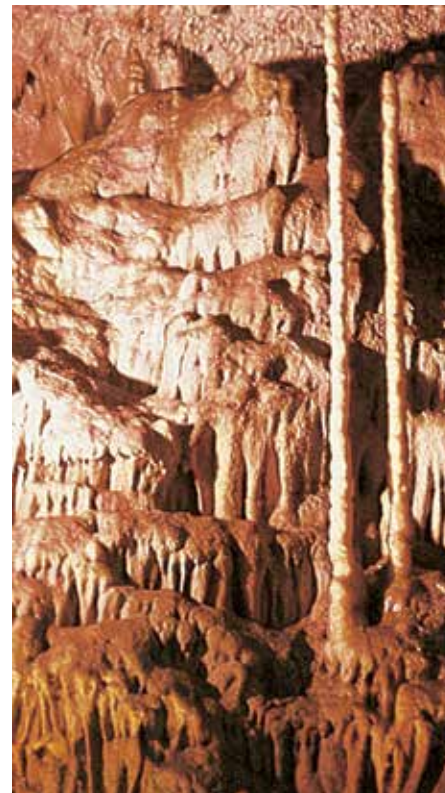

Cave with stalactites and stalagmites (the thin columns on the right)

EXPERIMENT 138

Heat the clear solution you obtained in Experiment 137 (insert boiling rod). The test tube contents will gradually turn cloudy. Pour 1 cm of it into a different test tube and heat, as in Experiment 136, until the water has evaporated. The "haze" is noticeably stronger than in Experiment 136. **A1**

In Experiment 137, the carbon dioxide contained in the sparkling water converted the insoluble calcium carbonate into soluble calcium hydrogen carbonate:



The relationships here are exactly the opposite from those with washing soda and baking soda. In that case, the calcium carbonate was easier to dissolve than the hydrogen carbonate. When the hydrogen carbonate solution is heated (Experiment 138), the reaction runs backwards from right to left in this case as well: The hard-to-dissolve calcium carbonate separates out again. And that's how the limescale gets into the kettle.



A water pipe narrowed by calcium deposits (photo: ELGA Berkefeld GmbH)



Hard water contains a certain quantity of calcium hydrogen carbonate, which converts back into insoluble calcium carbonate when heated (in a tea kettle or washing machine).

Plaster cast — from a chemical perspective

Reckless skiers sometimes break a leg. Then, they will have to walk around for a while with a plaster cast. The next experiment will show why plaster is used for this purpose.



Use only a small quantity of **plaster**. Avoid breathing dust. – Do not get in eyes, in mouth or on skin. Do not ingest.

EXPERIMENT 139

Additional material: Plaster for experiments 139–146.

Mix a little plaster — or, in chemical terms, calcium sulfate — with a little water to get a thick paste. After a little while, the plaster will be completely hard. Save some of the hardened plaster for Experiments 142 and 143. Residue: **A3**

The following experiments will show that plaster and slaked lime, which also gets hard when you mix it with water, are two different substances.



For **calcium hydroxide**, note the “Hazardous substances and mixtures” information starting on p. 7.

EXPERIMENT 140

Heat some slaked lime — that is, some of your calcium hydroxide with vinegar — in a test tube (use the boiling rod!). You will get a clear, colorless solution. **A1**

EXPERIMENT 141

Repeat the experiment with plaster. Even after you heat it a long time, the plaster won't dissolve. **A1**

EXPERIMENT 142

In a test tube, pour some vinegar over some lumps of hardened plaster from Experiment 139. In contrast to Experiment 132, you will not observe any gas formation, even when you heat it. **A1, A3**

While calcium hydroxide and calcium carbonate are dissolved by vinegar, plaster (calcium sulfate) resists this kind of attempt. Plaster isn't even eroded by the sorts of powerful acids that the chemist has available in a real lab.

And there are completely different processes going on when mortar and plaster harden. In the first case, the calcium hydroxide is converted through carbon dioxide uptake into calcium carbonate (out of which the carbon dioxide can be expelled again with acid). In the second case, the calcium sulfate hardens due to water absorption.

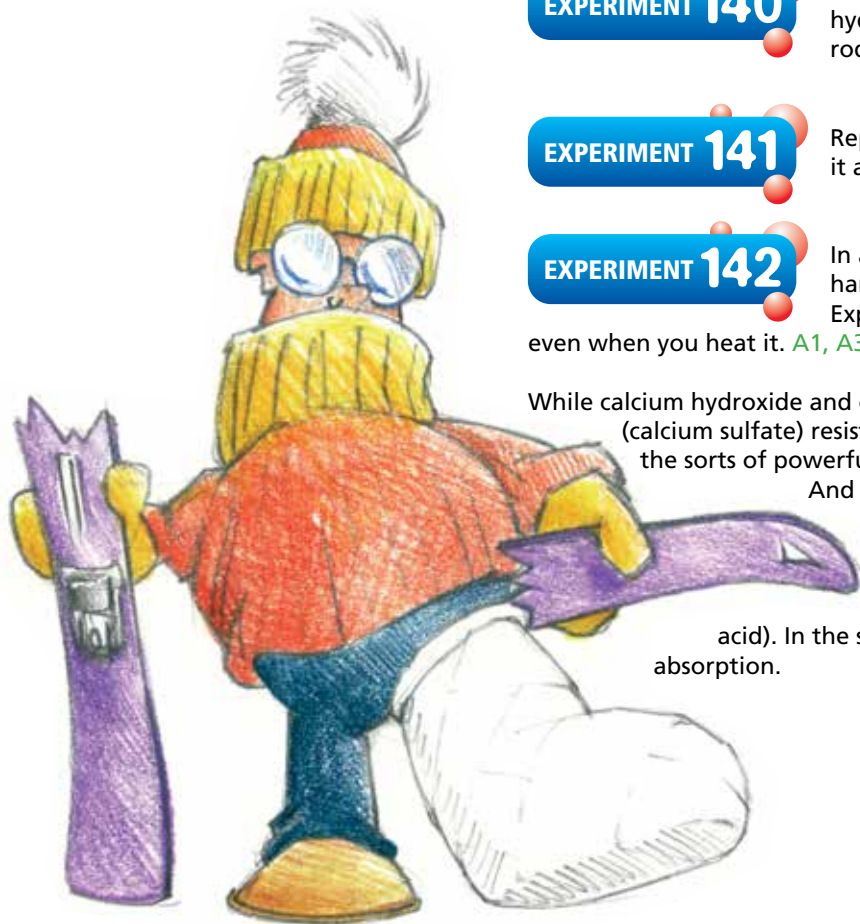

It depends on the water quantity

It is easy to determine that the plaster took up water as it hardened by performing a simple experiment.

EXPERIMENT 143

Heat some hardened plaster (from Experiment 143) in a dry, slightly tilted test tube. The water will condense into fine droplets near the mouth of the test tube. **A3**

EXPERIMENT 144

Put some plaster in a dry test tube (clamp it at a slight tilt again) and heat for 8–10 minutes. Again, you will see water condense at the cool end of the test tube. **A3**



Plaster is used a lot in model construction.



Question 29. What can you conclude from this?

EXPERIMENT 145

Mix the residue from Experiment 144 with water. The paste is no longer solid.



Gypsum is not only a sulfur compound, but a calcium compound as well.

Basic Knowledge



Dry water in crystals

The pretty, yellow-shimmering crystals and the inconspicuous white powder used to cover over holes in walls — these are actually one and the same substance, known variously as gypsum, plaster, or calcium sulfate in chemical terms. In nature, this substance usually occurs in the form of water-holding crystals. The water stored in these crystals is called **water of crystallization**.

Gypsum crystals contain two molecules of water of crystallization per calcium or sulfate ion. The complete formula for water of crystallization-holding gypsum is $\text{CaSO}_4 \cdot 2 \text{H}_2\text{O}$. Under moderate heating (up to 160°C), the gypsum loses three fourths of its water of crystallization and is converted into a powdery plaster of Paris with the formula $\text{CaSO}_4 \cdot \frac{1}{2} \text{H}_2\text{O}$ (in this case, with 2 calcium ions assigned to 1 molecule of water).

If you mix plaster of Paris with water, it reabsorbs the water of crystallization that it lost through heating. In the process, fine-grained, meshed crystals form — the plaster hardens. If you drive the remaining quarter of water of crystallization out of the plaster of Paris — as you did in Experiment 144 — you get plaster free of water of crystallization, which only hardens very slowly when you add water to it again, so it isn't suitable for plaster casts or wall plaster. Then, you would say that it is "over-burned."

You will re-encounter the "dry water" stored inside crystals when you work with copper sulfate (p. 92). Some of the substances that you have already experimented with contain water of crystallization as well, such as sodium hydrogen sulfate and citric acid.



Gypsum is not only a sulfur compound, but a calcium compound as well.



Counterfeiter at work

Would you have any interest in making a fake fifty-cent piece? It's perfectly legal as long as the coin is only made of wax.

EXPERIMENT 142

Additional material: Cardboard, cooking oil, coin or medal, candle wax, old spoon

First make some plaster paste as in Experiment 139, and transfer a 1-cm-thick layer of it onto an aluminum-foil-covered piece of cardboard or an old wooden board. Spread it smooth and press an oil-rubbed coin or medal into the plaster so that the top surface just sticks up out of the plaster.

Wait a few minutes and carefully lift out the coin (if necessary, use a pointed object to help pry it out). You have made a plaster mold. Wait for the plaster to dry completely. Then melt some candle wax in an old spoon, and pour it into the mold. Soon, you will be able to lift your "counterfeit money" out of the plaster. Of course, your coin has an aesthetic imperfection — it is only embossed on one side. **A3**



Motley crew of colored chalk — another use for calcium sulfate

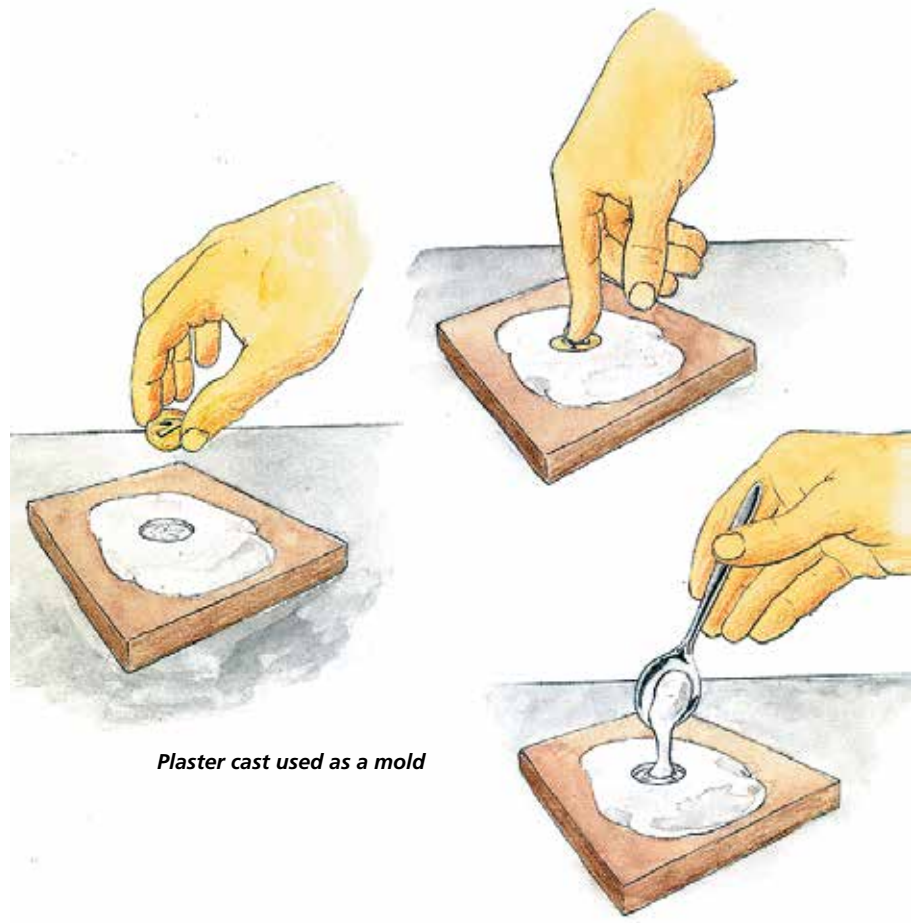

Plaster cast used as a mold

11

The Salt of Amun Ra

Now it's time to learn about another salt: ammonium chloride. It used to be known as sal ammoniac ("salt of Amun") as well. Ammonium chloride, like washing soda and baking soda, is a gas stockpile. But whereas you used acid to separate out the carbon dioxide from carbonates, you have to treat ammonium chloride with an alkali in order to release the gas — ammonia — contained within it. But let's start with the salt.

A salt that shies ways from heat



For **ammonium chloride**, note the "Hazardous substances and mixtures" information starting on p. 7. Perform the following experiments outside or next to an open window! Do not inhale the vapors that are created!

EXPERIMENT 147

Place 1 spoonful of ammonium chloride in a dry test tube and clamp it at a tilt, as shown in the illustration. Heat the ammonium chloride. Use the screw-top jar to capture some of the white fog escaping from the test tube. If you heat long enough, the ammonium chloride from the heated part of the test tube will disappear completely. On the other hand, in the colder part of the test tube near the opening, and less obviously in the jar as well, a white coating will have formed. The ammonium chloride, by the way, was not melted by the heat.

EXPERIMENT 148

Use the double-headed measuring spoon to scrape off as much of this white coating as possible and heat it in a dry test tube. Apparently, this coating is also ammonium chloride. **A1**

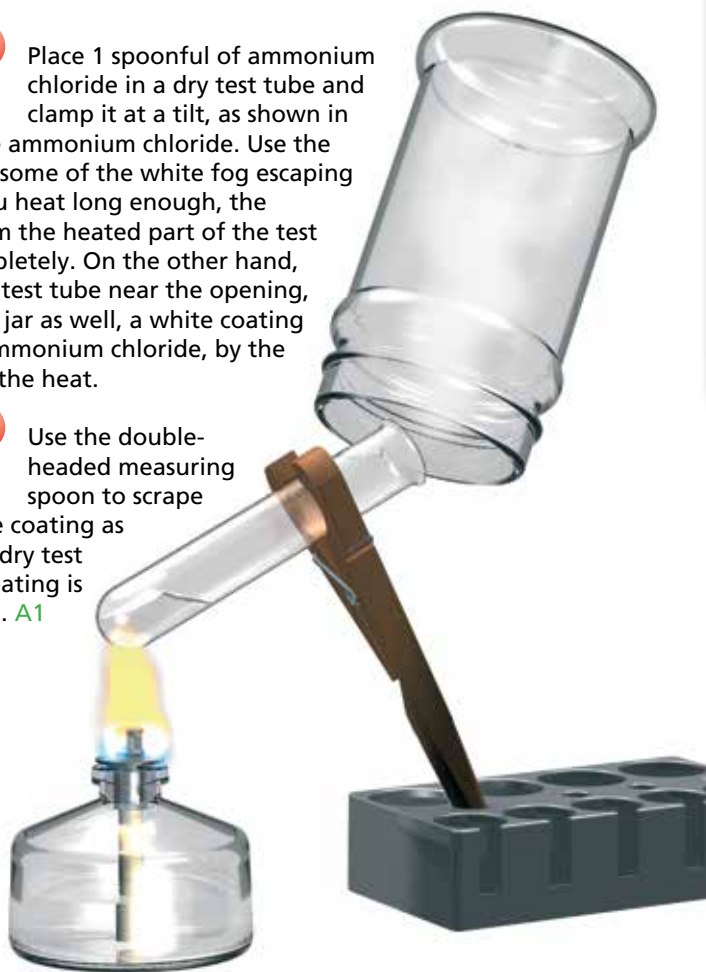

Ammonium chloride vaporizes without melting.

Side Notes

You take some camel dung...

... and table salt, mix thoroughly, and heat. That's how a recipe from ancient Egypt might have read, a recipe for making sal ammoniac. The name sal ammoniac comes from "salt of Amun," which was an oasis in the Libyan desert (near the Siwa Oasis of today). This oasis was the sanctuary of Amun, who was worshipped as a deity and later equated with the sun god Ra, hence Amun Ra. Due to his high rank, the Greeks also called him Zeus Amun, and the Romans Jupiter Amun.

But why camel dung?

Animal excrement contains nitrogen compounds, which form nitrogen- and chlorine-containing ammonium chloride when heated with table salt.



An oasis in the Libyan desert — birthplace of ammonium chloride?



Question 30. Do you know the three states of water?



Basic Knowledge

On states of matter and volatile solids

The composition of materials from smallest particles provides a simple explanation for **states of matter**. In a solid state, as you know, the particles are organized in a crystal lattice. They have little kinetic energy and won't budge. When you supply heat, the energy increases. At a certain temperature, the **melting point** of the material, the lattice falls apart. The material becomes liquid. The particles do still remain together, but move around more. At the **boiling point** of the material, the kinetic energy of the particles is so great that they depart from the liquid and go whizzing off into the air. Now, the material is in a gaseous state. Even beneath the boiling point, certain particularly energy-rich particles can leave the liquid: The liquid evaporates.

There are some materials that go directly from a solid to a gaseous state when they are heated, without melting first. This conversion is known as **sublimation**. In the reverse process, **deposition** or **desublimation**, the solid material separates directly out from the heated gas. That is what happened in the cooler part of the test tube and in the jar in Experiment 147. You were able to demonstrate in Experiment 148 that the coating consisted of ammonium chloride.

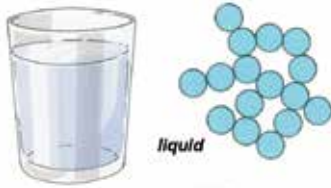
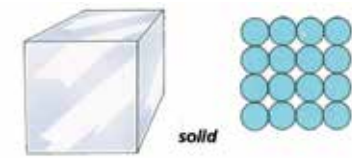

The states of matter, using water as an example

In separation and purification methods such as the one in the following experiment, sublimation is used to refer not just to the first partial step, but to the whole process: solid — gaseous — solid. The product that is purified in this way is called the sublimate.



For **ammonium chloride**, note the "Hazardous substances and mixtures" information starting on p. 7.

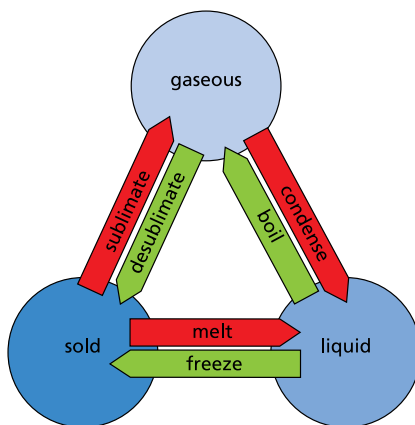

Transitions between the states of matter

EXPERIMENT 149

Measure 1 spoonful of ammonium chloride and 1 spoonful of table salt into a test tube, and proceed as in the previous experiments. By heating the white coating in a dry test tube, demonstrate that it is free from table salt — that is, that it consists purely of ammonium chloride. **A1**

Ammonium chloride has the formula NH_4Cl : Along with 1 nitrogen atom (N), you have 4 hydrogen atoms (H) and 1 chlorine atom (Cl). In contrast to solids that pass undecomposed into the gas state, ammonium chloride decomposes into two gases when heated: ammonia and hydrogen chloride.

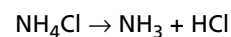

When cooled, the two gases combine back together into ammonium chloride.

The usefulness of ammonium chloride as a soldering aid also depends on its heat decomposition. If soldering compounds are to hold, the metal surfaces to be bound together must be free of impurities.

EXPERIMENT 150

Additional material: Aluminum foil or metal lid

Place 1 spoonful of ammonium chloride on a piece of aluminum foil or a metal lid. Clamp the copper wire in the test tube holder and hold the other end of the wire in the alcohol burner flame. The wire will turn black, forming a thin coating of copper oxide (CuO). Dip the still-hot wire in the ammonium chloride and then move it back into the flame again. The oxide layer will disappear, the shiny copper will make an appearance again, and the burner flame will briefly turn green. **Ammonium chloride: A1**

The hydrogen chloride produced during the heat-decomposition of ammonium chloride bonds with the copper oxide to make copper chloride (CuCl₂), which turns the flame green as it vaporizes:

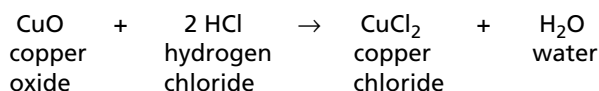

A sharp-smelling gas

Experiment outside or by an open window. Ventilate well after the experiment. Keep to the quantities indicated.



Ammonia is toxic if inhaled and causes severe skin burns and eye damage. – Do not breathe gas. – IF INHALED: Remove victim to fresh air and keep at rest in a position comfortable for breathing. – IF IN EYES: Rinse cautiously with water for several minutes. Remove contact lenses, if present and easy to do. Continue rinsing. – Immediately call a POISON CENTER or doctor.

You can't separate the ammonia and hydrogen chloride gases merely by heating them, since the substance will re-form when it cools. You have to chemically bind one of the components in order to release the other. To get ammonia, you have to bind the hydrogen chloride that is created when you decompose the ammonium chloride — for example, with calcium hydroxide, Ca(OH)₂:

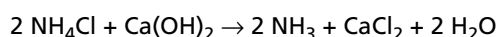

In case this is still a little too complicated for you, let's reformulate the reaction equation like this (NH₃HCl, of course, is none other than NH₄Cl):

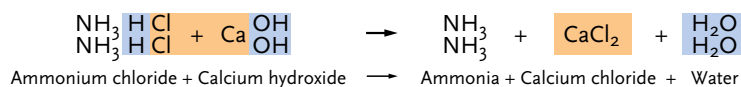

For **calcium hydroxide**, note the "Hazardous substances and mixtures" information starting on p. 7.

EXPERIMENT 151

In a test tube, mix one spoonful each of ammonium chloride and calcium hydroxide. Seal the test tube with the stopper (thumb over the stopper!) and shake briefly.

Open the test tube and carefully fan a little of the escaping vapors toward yourself. **A2**

You will notice an odor characteristic of certain cleaning products. Hold a damp piece of red litmus paper in the mouth of the test tube without touching the side walls. Why does it turn blue? Does ammonia have an alkaline reaction?



Copper gets covered with copper oxide when heated; when heated with ammonium chloride, the copper oxide combines with hydrogen chloride to form volatile copper chloride, which turns the flame green.

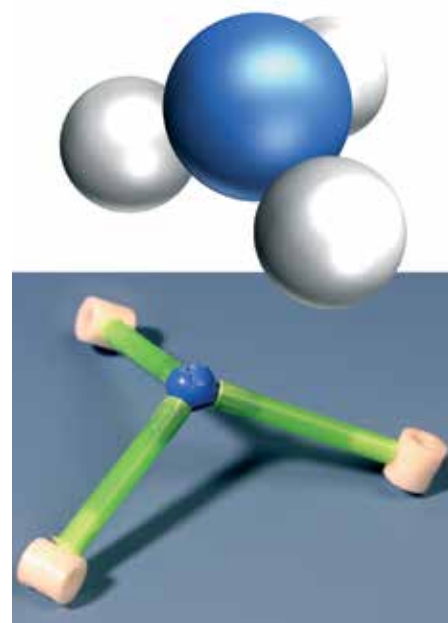

Ammonia molecule, NH₃



Modern high-pressure ammonia oven
(photo: Chemical Industry Fund)

TECHNOLOGY AND ENVIRONMENT



Nitrogen from the air

Ammonia plays an important role in our modern economy. People wouldn't have gotten very far if they had needed to rely on making it from camel dung and other animal wastes. Ammonia production is carried out on a large scale using the high-pressure synthesis method developed by Carl Bosch (1874–1940) and Fritz Haber (1868–1934). The term synthesis refers to the combination of starting materials into a new material.

The starting materials in ammonia synthesis are the two elements nitrogen and hydrogen. The nitrogen is obtained from the air, 80% of which is composed of this gas. The hydrogen is usually

obtained through conversion of the methane gas (CH_4) contained in natural gas using water vapor or steam. The reaction between nitrogen and hydrogen occurs in special reactors at 200 to 300 bar (in other words, 200 to 300 times atmospheric pressure) in the presence of a catalyst:

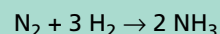

The ammonia produced in this way is removed from the reaction mixture by liquefying it under pressure. The chemical industry uses ammonia in the production of nitric acid, washing soda or soda ash (by the Solvay process) and fertilizer salts (ammonium sulfate), among other things.

Not the gas, but the solution in water. Ammonia reacts with water as follows:

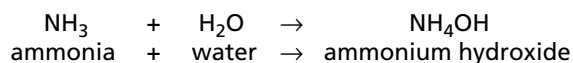

The ammonium hydroxide consists of the ammonium ion NH_4^+ and the hydrogen ion OH^- , which is responsible for the alkaline reaction of the solution.

Let's make ammonia spirits

"Ammonia spirits" are the "spirits," or the volatile component, that can be released from sal ammoniac, or ammonium chloride, just as you did in Experiment 151 — ammonia gas, in other words. These days, to the extent that the term ammonia spirits is used, people mean an ammonia solution in water, also known as ammonia water. In what follows, you will be producing ammonia-containing solutions



For **ammonium chloride**, **calcium hydroxide**, and **sodium carbonate**, note the "Hazardous substances and mixtures" information starting on p. 7.



Ammonium sulfate — a widely-used nitrogen fertilizer (photo: BASF)

EXPERIMENT 152

Measure 4–5 cm of water into a test tube with 2 spoonfuls of ammonium chloride and 2 spoonfuls of calcium hydroxide, seal the test tube with the stopper (thumb on top!), and shake. Filter the cloudy liquid into another test tube through a double layer of filter paper. Sniff carefully (do not inhale deeply) at the mouth of the test tube. Obvious ammonia odor! Hold a piece of moistened red litmus paper in the mouth of the test tube without touching the walls. The distinct blue color indicates volatile ammonia. **Residue: A3, filtrate: for experiment 153, residue: A2**



Question 31. Why shouldn't the test strip touch the test tube wall?

EXPERIMENT 153

Dilute some of the solution from Experiment 152 with five times the quantity of water and add some sodium carbonate solution to it. You will get a white precipitate.

Test to see how it reacts when you add vinegar to it. **A2**

The solution from Experiment 152 contains ammonia, but it isn't a pure ammonia solution. As the reaction equation on p. 79 indicates, it contains chloride carbonate as a side product, which forms a calcium carbonate precipitate with sodium carbonate solution. Calcium carbonate dissolves in acetic acid.

EXPERIMENT 154

Repeat Experiment 152 with sodium carbonate instead of calcium hydroxide. This time, you will get a clear solution right away, and you won't need to filter it. Save the

solution for the next experiment.

Blue invisible ink



For **copper sulfate**, note the "Hazardous substances and mixtures" information starting on p. 7.

EXPERIMENT 155

Additional material: Steel-nib fountain pen or fine artist's paintbrush

Dissolve 1 spoonful of copper sulfate in 3 cm of water and use the resulting pale blue solution to write a message, ideally on light blue paper. To develop it, you or the recipient of the secret message should use the ammonia-containing solution you set aside after the previous experiment. Soak some filter paper with the solution (by dripping it onto the paper with the pipette) and press the filter paper onto the paper you wrote on. The writing will turn a clear blue color. **A2, A3**

The blue color comes from a copper-ammonia compound that you will re-encounter in Chapter 13.



Hardly changed from the times of the ancient Egyptians — production of ammonia spirits from animal bones; from Stöckhardt, *The School of Chemistry* (1863)



A volatile salt

You may have seen movies set in centuries gone by, in which ladies had to be revived from a fainting spell with smelling salts. Those salts, which also sometimes went by the funny-sounding name salt of hartshorn but were chemically none other than ammonium carbonate and/or ammonium bicarbonate, are still used in Europe as a leavening agent in Christmas gingerbread. You may be able to find some hartshorn (perhaps under the name Hirschhornsalz or baking ammonia) in a specialty shop.



For **hartshorn**, note the "Hazardous substances and mixtures" information starting on p. 7.

EXPERIMENT 156

Add 2 spoonfuls of hartshorn to a test tube and perform a cautious sniff test (just sniff briefly). You will notice an ammonia odor, which will be more or less distinct

depending on how long the product was stored. As a comparison, sniff the chemical vial of ammonium chloride. You will not be able to detect any ammonia odor there. The fact that the ammonia in hartshorn is less strongly bound than that in ammonium chloride can also be seen in the two chemicals' different pH values in water-based solutions.



Salt of hartshorn — still used for Christmas cookies

Side Notes

Hartshorn

You may have heard of alchemists, who were the forerunners of chemists. While they had no luck transforming base metals into gold, they did make a lot of important discoveries in the realm of chemical substances. The salt that they produced by heating protein-containing animal remains — horn, hooves, and claws, for example — was very highly valued and used for medicinal purposes. It made a particular impression on them that the salt became volatile even at room temperature, giving off ammonia, or ammonia spirits. The salt was given the name alkali volubile, or volatile alkali.

Today, ammonium carbonate, which is the volatile component of hartshorn, is produced by heating a mixture of ammonium sulfate and calcium carbonate. It is used not just in baking, but for a lot of other purposes as well, such as in fire extinguishers.

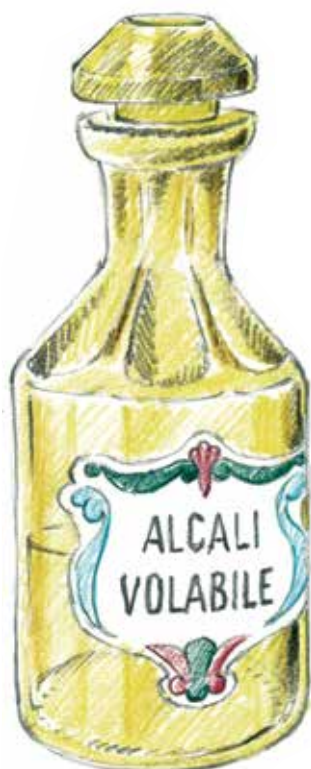

EXPERIMENT 157

Place 1 spoonful of hartshorn in one test tube and 1 spoonful of ammonium chloride in another, and add 5 cm of water to each. Spike both solutions with half a pipette of anthocyanin solution.

Ammonium chloride turns the anthocyanin solution a pale violet color, while hartshorn turns it a distinct green. Ammonium chloride has a slightly acidic reaction, while hartshorn has a slightly alkaline reaction.

EXPERIMENT 158

Repeat the experiment using litmus solution as the indicator (add two drops to each test tube). The ammonium chloride solution will turn reddish-violet (weakly acidic), while the hartshorn solution turns blue (alkaline). **A1**



For calcium hydroxide and limewater, note the "Hazardous substances and mixtures" information starting on p. 7. Be careful when twisting the angled tube into the stopper! Note the information on pages 13/14. In case of injury: **First Aid 7** (inside front cover).

EXPERIMENT 159

Add 3 cm of limewater to a test tube and place it in the test tube stand. Twist the short arm of the angled tube into the rubber stopper. To a second test tube, add 2 spoonfuls of hartshorn and 2 cm of vinegar. As soon as the foam has stopped rising, set the stopper with the angled tube into the test tube and let the free end of the angled tube dip into the test tube with the limewater. Do not let any foam or liquid get into the limewater, though. The white precipitate indicates carbon dioxide. **A1**

Hartshorn contains both ammonia and carbon dioxide. It is not a single material, by the way, but a mixture usually consisting of one part ammonium carbonate, $(\text{NH}_4)_2\text{CO}_3$, and two parts ammonium hydrogen carbonate, NH_4HCO_3 .

EXPERIMENT 160

Add 2 spoonfuls of hartshorn to a dry test tube and heat it over the alcohol burner flame. Hold the test tube tilted slightly toward the opening. Water will condense at the cold part of the test tube, but you won't get any salt coating like you did with the ammonium chloride. Eventually, the salt will disappear, having undergone a complete decomposition into ammonia, carbon dioxide, and water. In other words, only gases are produced. Water is gaseous at temperatures above 100 °C as well. So hartshorn perfectly satisfies the requirements of a leavening agent for baking — making the dough lighter through gas production.



12

Iron: #1 Commercial Metal

When a chemist is dealing with a metal, usually it's not with the element itself, but with its compounds, with the metal's salts, and with the characteristic reactions that serve as a test for the metal. The reactions usually take place in an aqueous solution, or a solution in water. Insoluble materials must be "unlocked," or converted into soluble ones. That applies to the metals themselves as well, of course. To dissolve metals, the professional has a variety of tools at his or her disposal, particularly acids. But you can also do it with — a salt.

Dissolving iron with copper sulfate



For copper sulfate, sodium carbonate, hydrogen peroxide, and sodium hydrogen sulfate, note the "Hazardous substances and mixtures" information starting on p. 7.

EXPERIMENT 161

Additional material: Shiny iron nail

Dissolve 1 small spoon tip of copper sulfate in 2–3 cm of water in a test tube. Place the nail in the solution. The nail will become covered in a dark, typically reddish-brown layer: copper. **Solution:** A4, nail: A3

With the iron nail, you were able to retrieve metallic copper out of the blue, water-soluble copper sulfate crystals. The next experiment will show that some iron was dissolved at the same time.

EXPERIMENT 162

Additional material: Steel wool, hydrogen peroxide

Dissolve a spoonful of copper sulfate in a test tube filled halfway with water, and add a small wad of steel wool to the solution. Seal the test tube with the stopper and shake vigorously (thumb over the stopper!). On the steel wool, just as happened with the nail, you will get a reddish-brown copper deposit. Let the test tube sit for another few minutes. The solution will no longer be blue, but a dull green. Filter into another test tube and add 1 small spoonful of sodium carbonate to the filtrate. You will get a green precipitate. Add a little hydrogen peroxide solution — the color will turn to brown — and heat with boiling rod inserted for 1–2 minutes. Add a spoonful of sodium hydrogen sulfate to the test tube contents. You will get a clear yellow solution. If you have a clean vial or bottle handy, you can save the solution in it. Attach a label to the bottle: **Iron(III) sulfate solution** (Do not allow to get into eyes or on skin!).
Steel wool: A3



Question 32. The reaction between copper sulfate and iron (steel wool) won't be completely new to you. Where else have you already encountered it?

For many of the experiments, you will be needing **potassium hexacyanoferrate(II) solution** (note the information starting on p. 7!). Because the compound is harmful to aquatic organisms, as little as possible of it should be allowed to go down the drain. Unfortunately, there are no simple disposal methods given the supplies available to you. So go carefully with the reagent and follow the tip on the right.



The iron nail pulls red copper out of the blue solution.

TIP

Dissolve 2 small spoonfuls of potassium hexacyanoferrate(II) in 10 cm of water and save the solution in a clean, labeled bottle. Take just the required quantity from the bottle (usually just a few drops). The products of reaction (particularly Prussian blue) can be poured down the drain along with sodium carbonate (or washing soda). Rinse well afterwards!

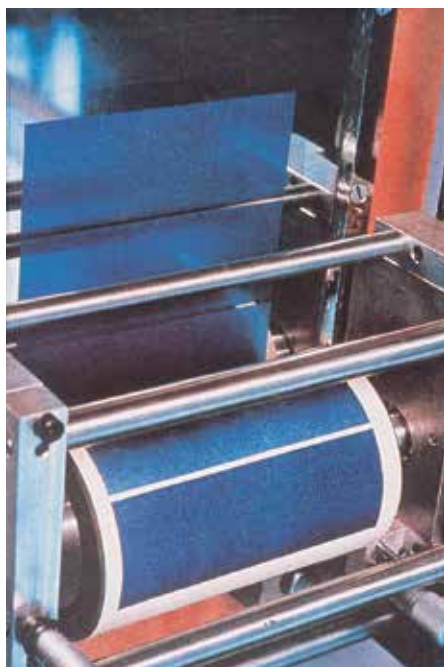

Prussian blue is not just useful as a reagent in the lab; it is also used as a dye in the printing industry (photo: Degussa AG).

Prussian blue indicates iron

EXPERIMENT 163

Add one pipette of the homemade iron(III) sulfate solution to 5 cm of water in a test tube. The solution will be practically colorless. Add a few drops of potassium hexacyanoferrate(II) solution: You will get a deep blue color, Prussian blue. **Tip, p. 83**
The reaction serves as a test for dissolved iron. The depth of color is due purely to dissolved iron. Undissolved iron does not react to the reagent.

EXPERIMENT 164

Additional material: Shiny iron nail
Place the iron nail in 2 cm of potassium hexacyanoferrate(II) solution in a test tube. Even after about half an hour, you will notice no change. **Pour the solution back into the container.**

Electrical current dissolves metals too

You already learned when you performed electrolysis on table salt solution that electrical current is capable of dissolving metals — even noble ones — when the metal is connected to the positive terminal of the current source.

EXPERIMENT 165

Additional material: 9-volt square battery, iron nail
Fill a graduated beaker up to the 50-ml mark with water and dissolve 1–2 spoonfuls of table salt in the water, stirring well. Attach two connection wires to the battery clip contacts. Take the free end of the wire attached to the positive terminal and wind it around the upper end of the iron nail. Let the nail, but not the wire, dip into the table salt solution. Take the free end of the wire coming from the negative terminal and let it simply hang in the solution.

At the negative terminal, you will get hydrogen (as in Experiment 107) and red litmus paper will turn blue (see the explanation on p. 63: “Migrants between two poles”). After a little while, a foamy, brown precipitate will spread through the solution. Save the contents of the beaker for the next experiment.

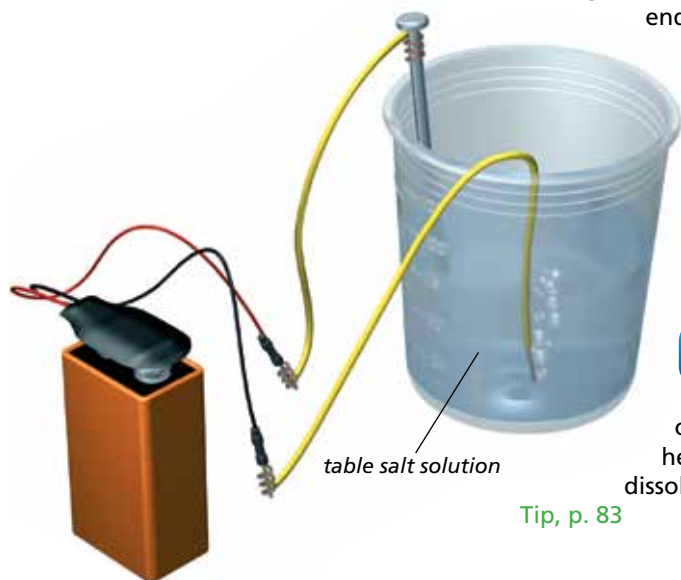

table salt solution

EXPERIMENT 166

Add 1–2 pipettes of the liquid from the previous experiment to 5 cm of water in a test tube. Add vinegar until the cloudiness disappears. After you add a few drops of potassium hexacyanoferrate(II) solution, the Prussian blue shows that iron was dissolved in the electrolysis process. It can only have come from the nail.

Tip, p. 83

Electrical current dissolves the iron nail.

Iron



Iron (Latin *ferrum*, chemical symbol Fe) has always been the most important commercial metal. The Hittites, who lived around 1400 BC in Asia Minor, already knew how to produce it. The first furnaces used to smelt iron from its raw materials, or from iron ore, date from around 1350 BC. In iron ores, the iron is usually bound to oxygen or sulfur. The sulfur-containing iron compounds are first converted into iron oxides, and then the metallic iron is removed from the iron oxides in the furnace through conversion with carbon monoxide. Most iron is processed into steel, which

reduces the carbon content of the raw iron from 4% to less than 1.7%. Pure iron is silverish-white and relatively soft. Damp air and carbon dioxide-containing water have an oxidizing effect — the iron rusts. By combining it with certain other metals into an alloys you get stainless steel, useful for kitchen and laboratory tools, among other things.

A characteristic property of iron, as you know, is the fact that it is magnetic. Iron is attracted by magnets, and certain types of iron can be used to make permanent magnets.

In the natural world — in plants and animals — iron plays an important role. The human organism contains 4–5 g of chemically bound iron, mostly in the protein found in red blood cells. These proteins are responsible for

the transport of life-essential oxygen through the entire body.



The magnetic property of iron is put to use in a compass.



Images from steel production
Left: Tapping raw iron from the furnace.
Middle: In the converter, the carbon component of the iron is reduced to 1.7% by blowing in oxygen. Impurities (such as sulfur and phosphorus) are bound to additives and separated out as slag.
Right: On the rolling mill, glowing blocks of steel are processed into steel girders, sheet metal, and other products.
 (Photos: ThyssenKrupp Steel)



Basic Knowledge

Noble and base metals

In Experiments 161 and 162, iron was dissolved while the "more noble" copper (Cu) precipitated out of the copper sulfate solution (CuSO₄):



Rather than being an isolated phenomenon, there is a general rule involved here, which says: A metal can precipitate a more noble one out of its solution. The reverse process is not possible. So, for example, you cannot precipitate iron from the iron(III) sulfate solution by using the copper wire. If you arrange metals according to their tendency to pass into a solution — that is, to form ions — you get the sequence shown in the adjacent table.

This series is sometimes known as the galvanic series or electropotential series of metals, because each metal can be assigned an electrical voltage with respect to a fixed reference point. That goes well beyond the bounds of this manual though.

The secret of the Roman numerals

The compound FeSO₄ that you got in Experiments 161 and 162 consists of a doubly positively charged iron ion (Fe²⁺) and a doubly negatively charged sulfate ion (SO₄²⁻); in technical terms, this is called iron(II) sulfate. Through treatment with hydrogen peroxide in an alkaline solution, we got iron(III) sulfate, which contains triply positively charged iron ions (Fe³⁺). Fe²⁺ ions were oxidized into Fe³⁺ ions. You already know that oxidation, in the broadest sense, is defined as an increase in charge.

So now you know what the Roman numerals in chemical names mean. Iron(II) sulfate contains Fe²⁺ ions, while iron(III) sulfate contains Fe³⁺ ions. The fact that potassium hexacyanoferrate(II) is likewise an iron compound is signaled by the -ferrate part of the name (from the already-mentioned Latin ferrum). And the addition of the Roman numeral for two betrays the fact that the compound contains Fe²⁺ ions. The name for the Roman numbers is **oxidation numbers**.

Compounds with different oxidation numbers also tend to display different reactions. So, for example, iron(II) sulfate yields a green precipitate with a sodium carbonate solution, while iron(III) sulfate yields a brown precipitate.

Tendency to form ions = oxidizability drops 	Potassium
	Calcium
	Sodium
	Magnesium
	Aluminum
	Manganese
	Zinc
	Iron
	Tin
	Lead
	Copper
	Silver
	Gold
	Platinum

"Galvanic series" of metals

Sodium hydrogen sulfate dissolves rust.



TIP
If you can't find cigarette ashes, you can dry and burn spinach or lettuce leaves, and then study the ashes as described.



Red rocks in southern France.

Iron where it won't surprise you...



For **sodium hydrogen sulfate** and **hydrogen peroxide**, note the "Hazardous substances and mixtures" information starting on p. 7. Work outside or by an open window! Do not inhale vapors.

EXPERIMENT 167

Additional material: Some rust

In a dry test tube, mix 2 spoonfuls of sodium hydrogen sulfate with a few flakes of rust, and heat the test tube with its opening slightly tilted down, as shown in the illustration. The salt mixture will turn yellow to brown. Stop heating and let the test tube cool. Take the test tube holder with the test tube in your hand, add some water to the test tube, and heat it again with the boiling rod inserted. Pour some of the yellow solution into another test tube and test it with the potassium hexacyanoferrate(II) solution. **Yellow solution: A2, Prussian blue: Tip, p. 83**

...and where you wouldn't suspect it

EXPERIMENT 168

Additional material: Cigarette ash (or leafy plant ash), hydrogen peroxide

In a test tube, add 3–4 cm water and 1 spoonful of sodium hydrogen sulfate to 4–5 spoonfuls of cigarette ash or cigar ash. Insert the boiling rod and heat for a few minutes. Filter the black broth through a double layer of filter paper and treat the clear filtrate with 8–10 drops of potassium hexacyanoferrate(II) solution. You will see it turn slightly green. As you slowly add hydrogen peroxide, the color will get more intense. **Tip, p. 83**

EXPERIMENT 169

Additional material: Wood ash

Repeat the previous experiment with some wood ash from the fireplace or barbecue. **Tip, p. 83**

Tobacco leaves, like other kinds of leaves and wood, contain the life-essential element iron. But because the quantity of iron is relatively low, all you usually get when you test for it with potassium hexacyanoferrate(II) is a green color, not the rich Prussian blue.

When going on hikes, you have probably seen red sandstone or red soil one time or another. In case you can't get your hands on a sample of soil or sandstone, you could use a chip of brick for the following experiments.

EXPERIMENT 170

Additional material: sandstone or piece of brick

Grind the stone or brick pieces to as fine a powder as possible, for example by using a hammer to hit them between two sheets of paper laid on an old board. Now mix 2 spoonfuls of the powder with 1 spoonful of sodium hydrogen sulfate in a test tube, and add 2–3 cm of water. Heat for a few minutes and then filter. Add an equal quantity of water to the filtrate along with 8–10 drops of potassium hexacyanoferrate(II) solution. You will immediately get a clear blue color, without having to add hydrogen peroxide. **Tip, p. 83**



Question 33. What can you conclude from this?

The color of red sandstone comes from red iron oxide. Iron oxide-containing rock is used in the production of red bricks as well. Iron oxide is practically insoluble in water, so in order to test for iron you will have to convert it into a soluble compound, as you did in the previous experiments. Since red iron oxide is an iron(III) compound, Prussian blue was formed as soon as you added the reagent.

Plays of color in the test tube

To end the chapter, you will be playing the role of a magician able to transform sunshine into the dark of night in the blink of an eye.



For **sodium carbonate** and **citric acid**, note the “Hazardous substances and mixtures” information starting on p. 7.

EXPERIMENT 171

Set three test tubes in the test tube stand. In the first one, dilute 1–2 cm of your homemade iron(III) sulfate solution with three times the quantity of water.

In the second test tube, place 1 small spoonful of citric acid, and place a few drops of potassium hexacyanoferrate(II) solution in the third. Your audience won't be able to notice these small quantities from a few meters away.

Pour the almost-clear iron(III) sulfate solution into the second test tube, seal it with the stopper, and shake. Yellow “sunshine” will shine forth from the test tube. Pour the sunshine into the third test tube. Swirl the test tube gently back and forth. Dark blue “night” has fallen.

The yellow sunshine is called forth by an iron-citric acid compound. In the third test tube, of course, you got the rich Prussian blue. But even after the longest night, a new day will dawn.

EXPERIMENT 172

Spike the Prussian blue from the previous experiment with sodium carbonate solution (2 spoonfuls to 3 cm of water). The blue will gradually turn into a pale yellow — a gloomy morning, so to speak. Add 1–2 cm of vinegar to it, seal the test tube, and shake! The solution will slowly turn to green and then blue. [Tip, p. 83](#)

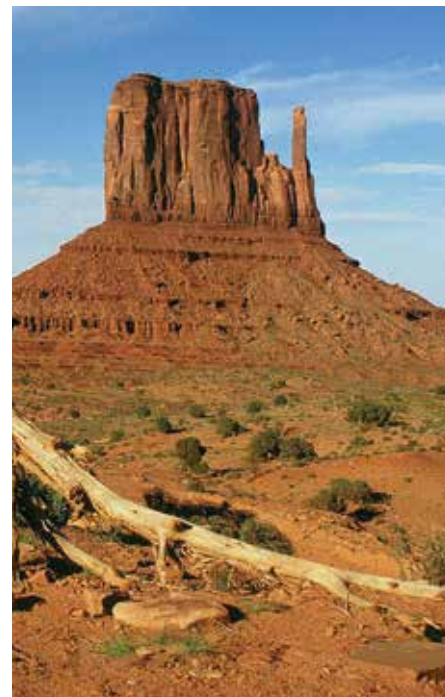

Red rocks in Monument Valley, Utah.



Question 34. What can you conclude from the previous experiment?

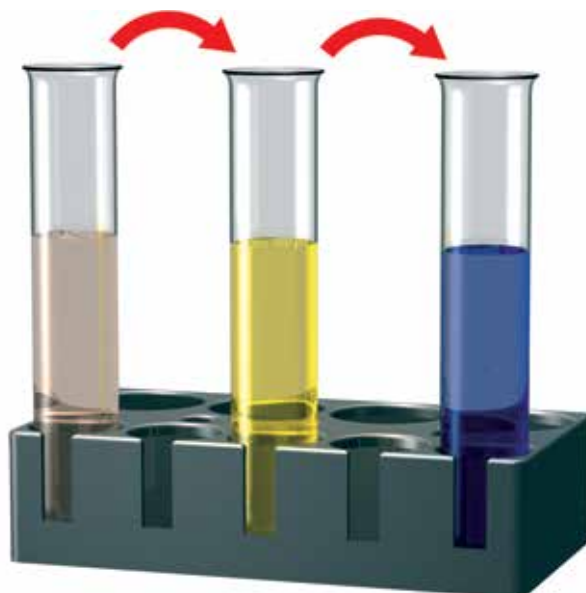

*Sunshine turns into the dark of night:
Left: diluted iron(III) sulfate solution
Middle: iron-citric acid compound
("sunshine")
Right: Prussian blue ("night")*

13

Copper: The Bright Red Semiprecious Metal



In nature, copper occurs as a shiny red metal.

At normal temperatures, copper is very slowly covered with a layer of oxidation. At higher temperatures, it's a different story.

When the copper wire turns black...

EXPERIMENT 173

Additional material: Tealight candle

There could be many reasons for copper wire turning black. Clamp one end of the copper wire in the test tube holder and hold the other end in a tealight candle flame. In no time at all, the copper wire will be covered in a layer of soot — like the knife in Experiment 80. Let the wire cool. The soot can be rubbed off with a piece of paper or a cloth.

EXPERIMENT 174

Hold the cleaned copper wire with the test tube holder in the upper part of the alcohol burner flame. It will turn dark again. As you heat it, you will see a pretty play of colors above the wire. After it has cooled, try rubbing off the wire again. This time, you won't be able to do it.

Copper is a widely-used material, increasingly so in building construction.



Copper

PROFILE

(Latin *cuprum*, chemical symbol Cu) has been known to humans for over 9,000 years. Six thousand years ago, the Egyptians were already smelting it from chunks of ore that they had collected. Bronze, the alloy of copper with tin, even gave its name to an entire age — the Bronze Age (2nd millennium BC). As a relatively noble metal, copper also occurs in its elemental form. Next to gold, it is the only metal with a characteristic color: the typical bright red. It will only bind to atmospheric oxygen at higher temperatures (Experiment 174).

In ores, copper either binds to sulfur (often along with iron) or occurs in the form of oxides and carbonates, such as in malachite or azurite (photo, right). A lot of copper minerals and copper compounds are distinguished by blue or green color tones.

Copper is one of the most frequently used non-iron metals. After silver, it has the best conductivity for electricity and heat, and therefore enjoys broad technical usage.

Copper is also an important trace element for humans, animals, and plants. The human body contains about 100–150 milligrams (mg) of copper as an enzyme component.

For microorganisms, copper and its compounds are powerful poisons, which means you have to avoid releasing them into

the environment. Please note the special disposal information for your experiments with copper.





For **denatured alcohol**, note the “Hazardous substances and mixtures” information starting on p. 7. Have an adult helper pour 2 cm of the alcohol into a test tube for you.

EXPERIMENT 175

Additional material: Denatured alcohol

Make a few coils at one end of the copper wire by winding it around a pencil. Clamp the other end of the copper wire in the test tube holder and heat the spiral in the burner flame until it turns black. Dip the hot spiral into the alcohol. It will hiss, gas bubbles will rise up, and the wire will be shinier than before. **Rinse the denatured alcohol down the drain with plenty of water.**

If you heat copper with a hot flame, the metal will bind with oxygen in the air to form copper oxide (see Experiment 150). If you combine hot copper oxide with alcohol, or ethyl alcohol, the copper oxide gives off its oxygen to the alcohol, leaving shiny copper remaining behind. The “semi-noble” character of copper is shown by the fact that it separates so easily from oxygen again. This experiment wouldn’t work with iron oxide.

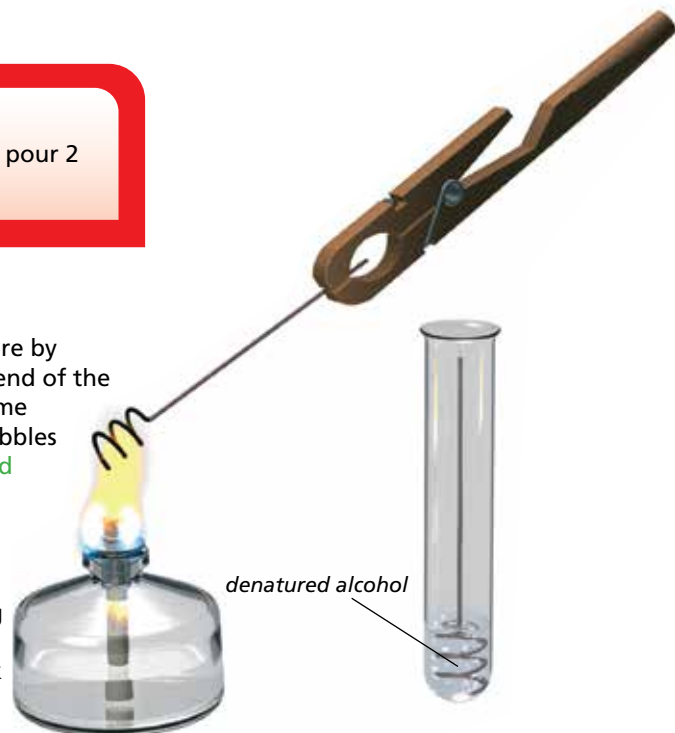

denatured alcohol

The copper wire turns black — and then shiny again.

It also works without nitric acid

Now let’s dissolve some copper. Not in water, of course. The chemist uses sulfuric or nitric acid for this. We will use a salt again: in this case, sodium hydrogen sulfate. Perform the experiment outside or by an open window. Ventilate well after the experiment! Keep to the specified quantities.



For **sulfur dioxide**, see hazard and precautionary statements on p. 34.

For **sodium hydrogen sulfate**, note the “Hazardous substances and mixtures” information starting on p. 7.

EXPERIMENT 176

Use the pliers to cut a section about 1 cm in length from the copper wire, and place it in a dry test tube along with 2 spoonfuls of sodium hydrogen sulfate. Clamp the test tube in the test tube holder at a slight tilt, open end down, and heat it. The sodium hydrogen sulfate will melt and water vapor will escape from the mouth of the test tube. Sodium hydrogen sulfate contains water of crystallization, just as do plaster (Experiments 143, 144) and copper sulfate (Experiment 184). When the water has evaporated, the melted salt starts to turn a gray to bluish-green color. At the same time, the pungent-smelling vapors of sulfur dioxide will start to escape as well. After 2–3 minutes, stop heating. The melted mass of salt will harden again.

EXPERIMENT 177

Additional material: Iron nail

Wait for the test tube to cool off. Then, add 5–6 cm of water to it and heat. Insert the boiling rod!

The hardened salt mass will dissolve. The copper wire will either have disappeared completely or at least gotten a lot thinner. The solution will be a pale blue. Save half of the solution for Experiments 178 and 179. Place a shiny iron nail in the solution. **A4**

sodium hydrogen sulfate + copper



Sodium hydrogen sulfate dissolves copper; a professional would use concentrated acids to do this.



Question 35. What do you observe? What can you conclude from this observation?



Nitric acid doesn't just dissolve copper; it also dissolves silver, but not gold. This acid used to be used as an "aqua fortis" to recognize whether gold had been "diluted" with less-noble metals.

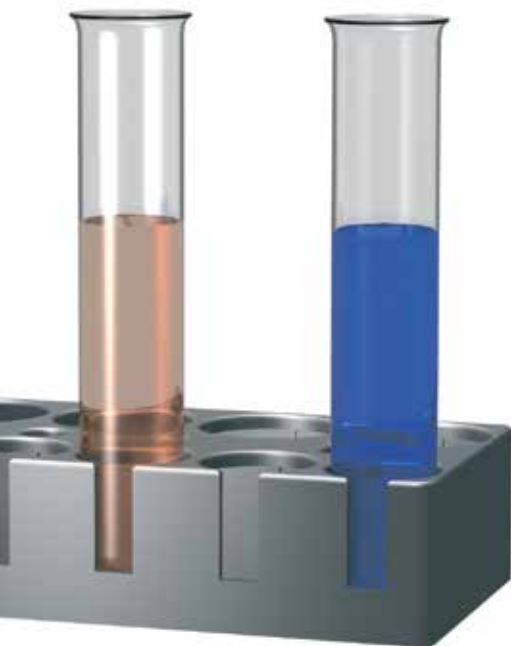

Test for copper with potassium hexacyanoferrate(II) (left) and ammonia solution

If you heat copper and sodium hydrogen sulfate, the sodium hydrogen sulfate will decompose. In the process, sulfur trioxide (SO_3) is created, which oxidizes the copper to copper oxide, CuO . At the same time, sulfur dioxide, SO_2 , is released:

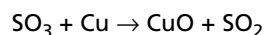

The copper oxide binds to another molecule of sulfur trioxide to form copper sulfate, CuSO_4 :

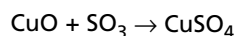

After the mass dissolved, a copper sulfate solution was created, in which you could demonstrate the presence of copper by using the "nail test" as in Experiment 161.

Textbook tests for copper

There are still other reactions that can be used to test for copper — or, more precisely, copper ions. They can be found in any textbook of chemical analysis. By **analysis**, a chemist may mean the *decomposition into component substances* of a compound or a mixture, but it can also refer to the test for a certain component in compounds or mixtures.



For **copper sulfate**, **ammonium chloride**, and **sodium carbonate**, note the "Hazardous substances and mixtures" information starting on p. 7.

EXPERIMENT 178

Dissolve 1 small spoonful of copper sulfate in half a test tube of water. The blue color of the copper sulfate is barely recognizable. Divide the solution in half. To one half, add 10 drops of potassium hexacyanoferrate(II) solution (the solution you prepared according to the tip on p. 83). You will get a reddish-brown precipitate of copper hexacyanoferrate(II). All reddish-brown precipitates: **A6**

Pour the other half of the copper sulfate solution into a screw-top jar and fill the jar with water. Fill a test tube halfway with this highly diluted copper sulfate solution, using the pipette to do this (the solution is hard to pour directly from the screw-top jar). Add another 10 drops of the potassium hexacyanoferrate(II) solution to the test tube with the diluted solution. You will still get a distinct color. What you have here — as a chemist would say — is a sensitive test.

Now, use potassium hexacyanoferrate(II) solution to test the half of the copper sulfate solution you set aside from Experiment 177. Once again, you will get the reddish-brown precipitate.

EXPERIMENT 179

Dissolve 1 small spoonful of copper sulfate in half a test tube of water. An ammonia solution will serve as the testing agent, which you can prepare as you did in Experiment 154 by dissolving 2 spoonfuls each of ammonium chloride and sodium carbonate in 5 cm of water (note the information before Experiment 152!). Add half of this solution to the dilute copper sulfate solution.

Test the rest of the homemade copper sulfate solution from Experiment 177 with the ammonia solution.

The blue color comes from a copper-ammonia compound that you've come across before. **A5**



Question 36. Do you remember which experiment?

Withdrawing copper...

We're thinking of electrical current. You already know that it can dissolve iron. But copper poses no difficulties for it either. You will need a 9-volt square battery for the following experiments.



For **sodium hydrogen sulfate**, note the "Hazardous substances and mixtures" information starting on p. 7.

EXPERIMENT 180

Assemble the experimental setup shown in the illustration. Fill the beaker with a solution of 2 spoonfuls of sodium hydrogen sulfate in 75 milliliters of water. As soon as the copper wire is immersed in the solution, it closes the circuit. Hydrogen will rise up from the negative terminal, just as in Experiments 107 and 165. At the positive terminal, or the copper wire, you will not be able to observe any gas development. Instead, a bluish-green spot will form under the copper wire at the bottom of the beaker. Let the electrolysis continue while you perform the next experiment.

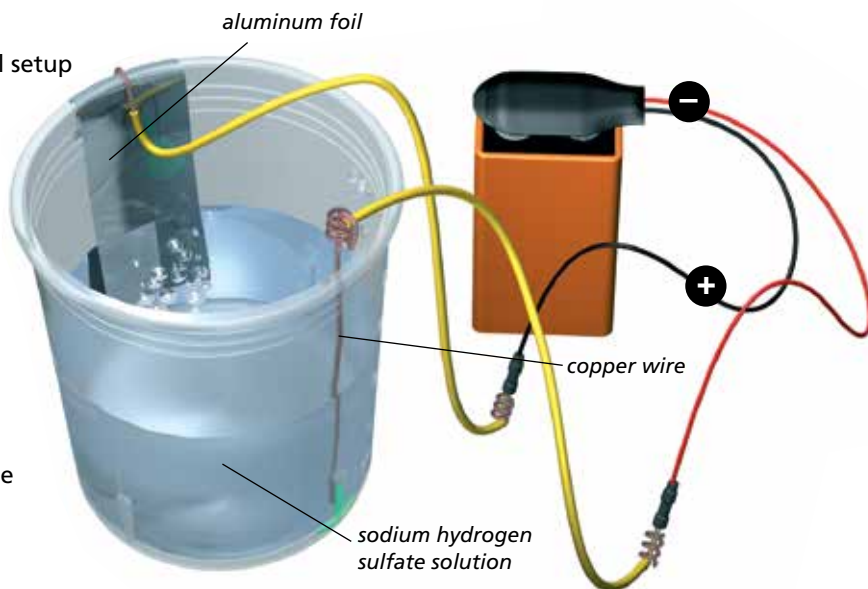

EXPERIMENT 181

Measure 2–3 pipettes of the contents of the graduated beaker from Experiment 180 to a test tube, and add a few drops of potassium hexacyanoferrate(II) solution: brown color. **A6**

With this experimental apparatus, no negative chloride ions are discharged at the positively charged copper wire, so no chlorine is released; instead, copper from the wire is dissolved, just as iron from a nail was dissolved in Experiment 165. You get positively charged metal ions that you can test for in the solutions.

The electrical current dissolves copper.

... and depositing it again

Once Experiment 180 has run for a while, you will be able to observe the formation of dark spots on the aluminum foil.

EXPERIMENT 182

Interrupt the electrolysis and take the aluminum foil out of the beaker. Wipe the foil against some folded filter paper. A few dark spots will remain behind on the paper. Spread out the filter paper and add a few drops of ammonia solution (produced as in Experiment 154) to the spots. You will gradually get a blue color, weak at first but increasingly distinct. The coating on the aluminum foil and filter paper, apparently, consists of copper. **Aluminum foil and paper: A3, solution: A4**

Summing up: The copper is not merely dissolved at the positive terminal, but also to some extent deposited again at the negative terminal. Why aren't the positively charged copper ions migrating to the negative pole? In the following experiment, the copper deposition will be clearer.

EXPERIMENT 183

To a test tube filled four-fifths with water, add a spoonful each of sodium hydrogen sulfate and copper sulfate, and assemble the experimental setup shown. As soon as the circuit is closed, despite lively hydrogen production, dark flakes will start to settle on the aluminum foil — it's copper. If you use more highly concentrated solutions (not recommended, due to your limited chemical supplies), you will get a solid copper coating that sticks to the aluminum foil.

Copper: A3, solution: A4

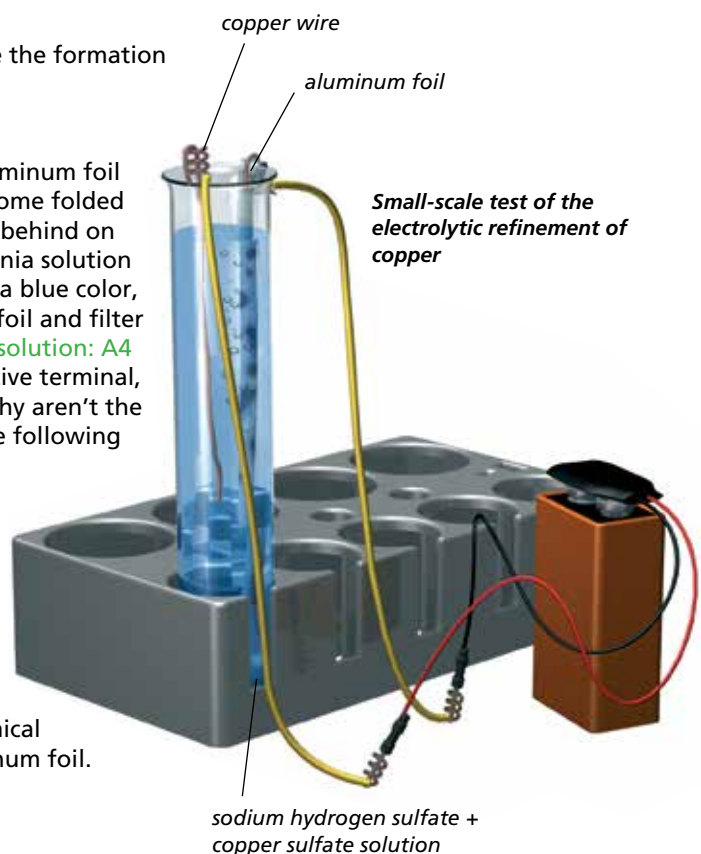



Industrial copper refining through electrolysis; the copper separates out onto the suspended plates (photo: Lurgi).

TECHNOLOGY AND ENVIRONMENT



Refinement of copper

In the previous experiment, you copied an actual industrial process: the purification of raw copper through electrolytic refinement. Raw copper that has been pre-refined through several steps (containing 97–99% copper) is poured into plates that are immersed in a solution of copper sulfate and sulfuric acid and

connected to the positive terminal of a current source. When the current flows, there ensues a deposition of purified copper (99.95%) at the negative terminal (plates of pure copper), while the impurities, which can in themselves be quite valuable (gold, silver, lead, antimony), collect in the electrolysis vat as sludge. Copper that has been purified in this way is called electrolytic copper.

Copper sulfate contains water of crystallization



For **copper sulfate**, note the “Hazardous substances and mixtures” information starting on p. 7.

EXPERIMENT 184

Place a spoonful of copper sulfate crystals in a test tube that is dry both inside and out, and clamp the test tube in the test tube holder with its open end tilted slightly down. Heat the copper sulfate crystals. They will gradually decompose into a white or greenish-white powder. In the colder part of the test tube, you will get a condensate of fine droplets: the water of crystallization.

EXPERIMENT 185

Wait for the test tube to cool enough to touch it. Remove the water droplets with a little rolled-up bit of paper towel. Divide the white powder between two dry test tubes and add some water to one. The white powder will turn blue again. **A4**

The blue, water of crystallization-containing copper sulfate has the formula $\text{CuSO}_4 \cdot 5 \text{H}_2\text{O}$, meaning that the crystals contain 5 molecules of water for each Cu or SO_4 ion. In Experiment 184, you expelled the water of crystallization to produce the white, water of crystallization-free copper sulfate. When you add water (Experiment 185), the blue crystals re-form.



For **denatured alcohol**, note the “Hazardous substances and mixtures” information starting on p. 7. Have an adult helper pour 2 cm of alcohol into the test tube for you.

EXPERIMENT 186

Pour the alcohol into the test tube along with the rest of the water-free copper sulfate. At first glance, nothing much happens. But if you watch for a while, you will notice that the copper sulfate slowly turns blue.



Question 37. What can you conclude from this?

Water-free copper sulfate can be used to test for water. Pour the alcohol off of the copper sulfate and dilute it with water: **A1**. Take the test tube with the undiluted copper sulfate, fill it halfway with water, and shake: **A4**



When the blue copper sulfate crystals are heated, you get white copper sulfate free of water of crystallization.



Denatured alcohol only contains a small amount of water, so you only get a weak blue color with the water-free copper sulfate.

Blue sky — dark clouds

To complete your experiments with the element copper, here's another "never-ending story" — in other words, a sequence of reactions that you can keep starting over and over again from the beginning, as long as you want.



For **sodium hydrogen sulfate** and **sodium carbonate**, note the "Hazardous substances and mixtures" information starting on p. 7.

EXPERIMENT 187

Measure 2 cm of water into each of two test tubes. In the first, dissolve 1 small spoonful of copper sulfate, and in the second dissolve 2 small spoonfuls of sodium carbonate. Pour the two solutions together. You will get a blue precipitate: the blue sky.

EXPERIMENT 188

Set the boiling rod in the blue liquid and heat. Be careful not to let the boiling liquid spray you or someone else in the face! After just a few seconds, dark streaks will form: the clouds. If you keep heating, the entire test tube contents will turn black. Before you know it, you'll have a real storm on your hands. Let the test tube cool off!

EXPERIMENT 189

But after every storm there's sunshine and blue skies. Add 1 spoonful of sodium hydrogen sulfate to the black precipitate and heat. The precipitate will dissolve and you will get a clear, light blue solution. If you add sodium carbonate solution to the cooled solution, the sky-blue precipitate will return and you can start the game over again from the beginning. Regular spring weather! **Solution: A4, precipitate: A6**

When you poured the copper sulfate and sodium carbonate solutions together, you got a sky-blue, alkaline copper carbonate, a double compound of CuCO_3 and Cu(OH)_2 . This blue precipitate decomposed when heated and formed a black copper oxide. When heated with sodium hydrogen sulfate, the copper oxide dissolved and you got the copper sulfate solution again, from which the precipitate of alkaline copper carbonate once again separated out when you added sodium carbonate solution.

Alkaline copper carbonate also occurs in nature, such as in malachite or azurite. The green coating on copper roofs or statues, or **patina**, once mainly consisted of alkaline copper carbonate, but today it also consists of alkaline copper sulfate due to sulfuric acid precipitation (acid rain).



Malachite (polished)



Patina on the copper of the Statue of Liberty

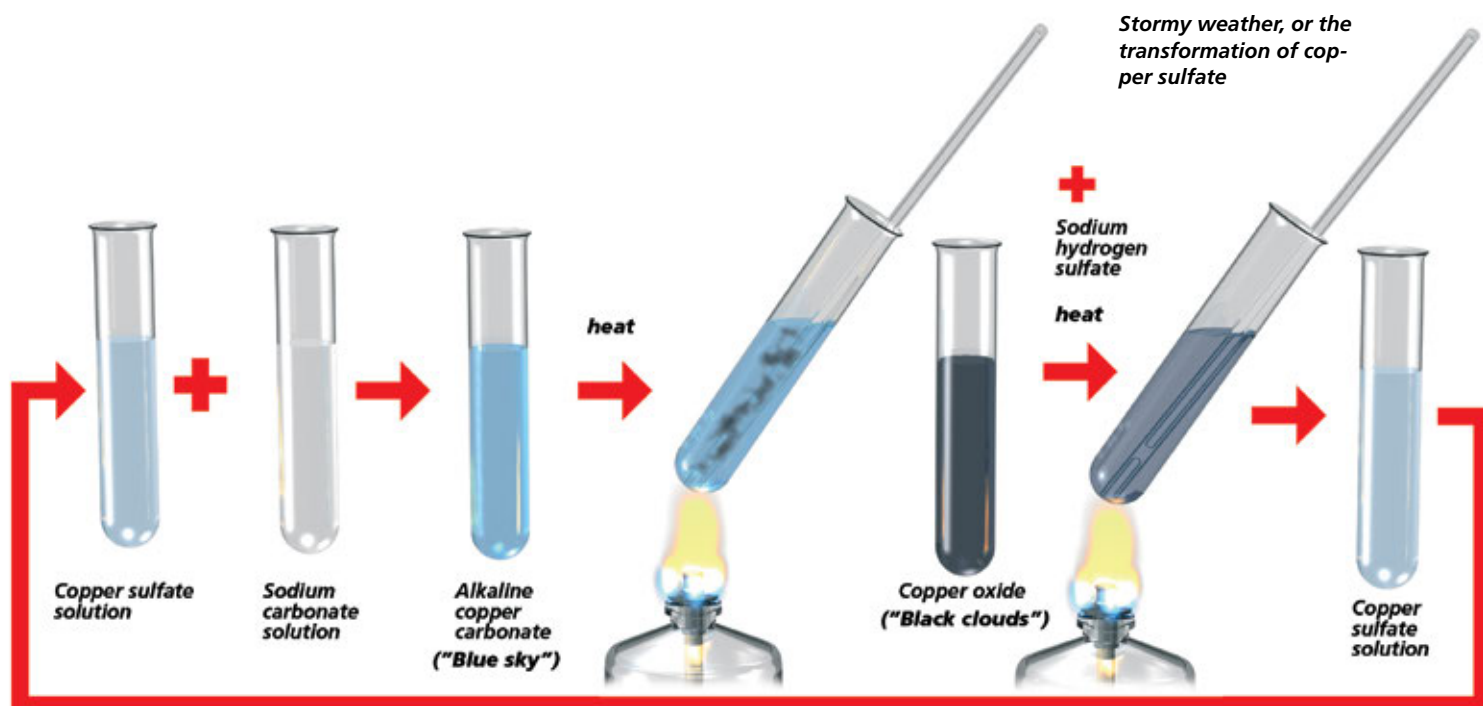

14

Colorful Chemistry on Paper



Reagent papers from the professional lab: red litmus paper (bases), blue litmus paper (acids), potassium iodide starch paper (chlorine and other oxidizers), lead acetate paper (hydrogen sulfide), universal indicator paper (pH).



The secret message is decoded.

Invisible inks from the kitchen



You have already carried out a few experiments on or with paper, such as the production and use of test papers: anthocyanin paper and red litmus paper as a test for alkali, iodide paper as a test for chlorine. With “semi-dry” electrolysis too, chemical reactions took place on paper. In this chapter, experiments on paper will be right at the center of things. From invisible inks to color races, this is a special field of chemical analysis known as **paper chromatography**.

General disposal instructions for this chapter: solutions A1, paper A3

Invisible inks from the chemistry kit

You already tried out a blue invisible ink in Experiment 155. Now you can try the following inks as well.

EXPERIMENT 190

Additional material: Fountain pen with steel nib or fine artist's paintbrush, paper

Another blue invisible ink: For your ink, you can use an iron(III) sulfate solution, such as the one you made in Experiment 162. Ideally, write your message on yellow-toned paper. After it has dried, you won't see a thing.



Question 38. What will the recipient of your secret message have to do to “develop” the invisible ink?



For **copper sulfate**, note the “Hazardous substances and mixtures” information starting on p. 7.

EXPERIMENT 191

Additional material: As in Experiment 190

Brown invisible ink: If you worked your way through the entire previous chapter, it probably won't be very hard for you to formulate instructions for a brown invisible ink. Use copper sulfate solution (1 small spoonful with 1 cm of water in a test tube) as your ink.



Question 39. What will the recipient need to decipher your message? What is the brown ink made of?

Invisible inks from the kitchen

With the invisible inks from the chemistry kit, the recipient will always need to have the chemicals required to reveal the message, of course. That's no problem as long as or she he owns a chemistry set. Otherwise, you can also try using lemon juice, vinegar, or onion juice.

EXPERIMENT 192

Additional material: Lemon juice, fountain pen with steel nib or fine paintbrush

Squeeze the juice from half a lemon and use the juice as your "ink." The pen or brush shouldn't be too thin. After the "ink" has dried, you won't be able to see it anymore either. To render your secret message visible, you or the recipient will have to heat the paper quite a bit, but not so much that it goes up in flames! The best technique is to use an electric hot plate on a low setting. Still, don't hold the paper too close to the heat source, and be careful not to burn yourself. What do you see?

EXPERIMENT 193

Repeat the experiment with vinegar or onion juice (ideally, make it with a vegetable or garlic press).

With these invisible inks from the kitchen, the process of turning visible rests on the fact that when they are heated, the materials that the inks are made of will carbonize a little (brown color).

Electrolysis on paper

The "semi-dry" analysis you practiced in Chapter 8 can come in handy in a lot of situations, since you don't have to file off part of the object under investigation and dissolve it in acid, as you do in conventional "wet chemistry." For the following experiments, you will need to set up a lid as shown in the illustration on p. 63.

Additional material: 9-volt square battery

EXPERIMENT 194

Soak a multi-ply piece of paper towel in table salt solution and place it on the aluminum foil. Press a penny onto the paper and touch the coin with the red wire contact. After a few seconds, pick up the coin and place 1 drop of the potassium hexacyanoferrate(II) solution described on p. 83 to the green-colored spot. The brown color indicates copper.

EXPERIMENT 195

Repeat the experiment, but instead of the potassium hexacyanoferrate(II) solution add 1 drop of liquid ammonia (production as in Experiment 154) to the paper.

The blue color indicates copper.

EXPERIMENT 196

Repeat Experiment 194, but this time investigate an iron object; a nail or screw will also do.



Question 40. How do you conduct the test for iron?

Side Notes

Oil of vitriol and liquor of tartar

Would you like to learn a very old recipe for invisible ink? Here is one: "If you melt a little white or green vitriol in water and write with it, you won't be able to see the letters unless you smear them with boiled oak-gall water.

If you want to get rid of the letters, simply wipe them with oil of vitriol and they will disappear in a flash.

But if someone wants to read these letters again, he merely has to pass a little liquor of tartar over them and they will reappear with a yellowish hue."

The white or green vitriol is iron(III) sulfate, which makes black ink (iron gall ink) with gall-apple extract (which contains tannic acid). The oil of vitriol is none other than sulfuric acid, which people used to obtain by heating metal sulfates known as vitriol (in this case, of course, diluted acid was used). There are other acids that will make the iron gall ink disappear as well. Liquor of tartar is a concentrated potassium carbonate solution, which, like soda ash, has an alkaline reaction and neutralizes the sulfuric acid, bringing the writing back to life (yellow color). Liquor of tartar got its name from the fact that was made from a potassium salt of tartaric acid obtained in the wine-making process, which would dissolve into a "liquor" or oily liquid when exposed to the air. This recipe comes from a book called "Natural Magic Book, Newly-Opened Playground of Rare Arts," written in 1745.

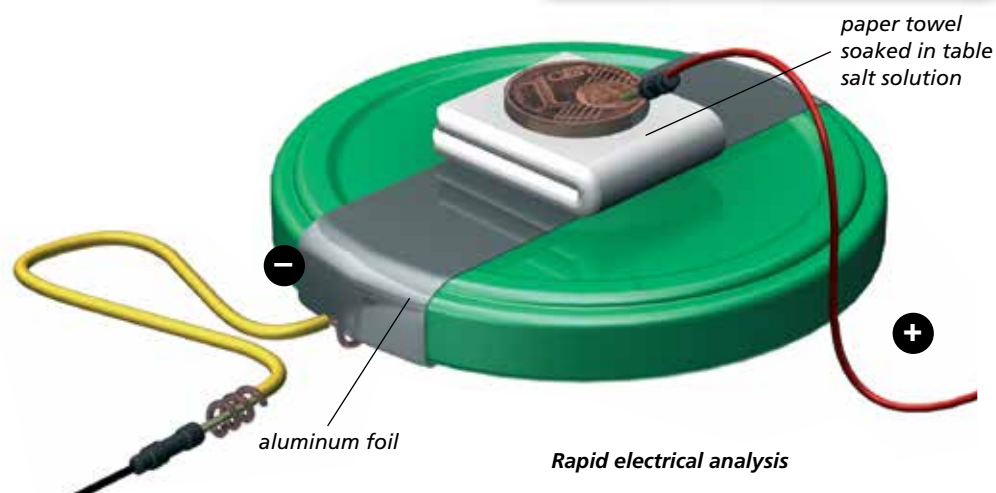



For **sodium carbonate** and **hydrogen peroxide**, note the “Hazardous substances and mixtures” information starting on p. 7.



How to set up a jar for the following experiments.

EXPERIMENT 197

Additional material: *Hydrogen peroxide*

Proceed as in Experiment 194, but this time soak a multi-ply paper towel with sodium carbonate solution (to be thrifty with it, use the pipette to drip some onto the paper) and investigate the cleaned iron object. The paper will turn a greenish color, and then when you add a few drops of hydrogen peroxide, it will change to brown.

In this case, what you got was iron(II) hydroxide, which was oxidized to brown iron(III) hydroxide by hydrogen peroxide.

Paper isn't paper

Turn a jar lid upside down, as shown in the illustration. Glue a cork to the underside of the lid and insert a small hook, which you can make from a paper clip, into the cork.

EXPERIMENT 198

From a sheet of white writing paper, cut a strip 1–2 cm wide and the appropriate length to hang 1–2 cm from the bottom of the jar. Make a small hole at one end of the strip. Put enough water in the jar for the strip to dip a few millimeters into it.



Question 41. What do you observe?

EXPERIMENT 199

Repeat the experiment with the same size piece of filter paper, which you can cut from a white coffee filter.



Question 42. What do you observe?

The filter paper you used has a loose texture because, unlike writing paper, it hasn't been limed. It consists of many thousands of very fine tubes known as capillaries. The capillaries have a suction effect on the liquid, which is so strong that the liquid — against the flow of gravity — rises up a vertically suspended strip of paper. It will easily absorb or blot up any drop of liquid it touches, which is why it is also called blotting paper.

Writing paper and filter paper when dipped in a liquid.



Black ink isn't so black after all

EXPERIMENT 200

Additional material: Black ink, pin

Cut several strips of filter paper of the same size as the ones you used in the previous experiment. Dip the head of a pin in some black (!) ink and dab the small amount of ink clinging to the pin head onto one of the filter paper strips, about 1 cm from its lower edge. Suspend the prepared strip in a screw-top jar that holds just enough water for the end of the strip to dip into it, but not the ink spot. You just have to do it by trial and error. The water will rise up the filter paper, reach the ink spot, and pull the ink along, revealing several patches of color that pass one into the next. Take the filter paper out of the jar before the water reaches the hook, and spread it out on a paper towel to dry.

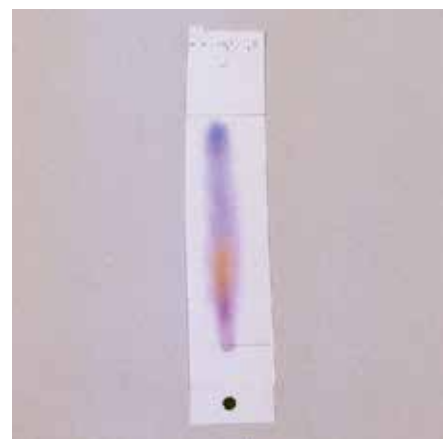

Black ink is decomposed.



For **denatured alcohol**, note the "Hazardous substances and mixtures" information starting on p. 7. Have an adult helper pour 2 cm of the alcohol into a test tube for you.

The separation process will work even better if you use a denatured alcohol mixture in the jar instead of water (mix 4 cm of water with 3 cm of alcohol in a test tube). Keep the rest of the water-alcohol mixture well sealed and labeled for Experiments 202 and 204. Let the filter paper dry outside or by an open window.

Apparently, rather than containing one single dye, the black ink contains several of them, and they climb up the filter paper strip at different speeds.



Colorful felt-tip pens

Race of colors

The colors in felt-tip markers often consist of several components as well. There are pens with water-soluble colors (especially for children), but there are also "permanent" ones that contain a quick-evaporating, sometimes medicinal-smelling solvent, and that therefore bear the message: "Close after opening."

EXPERIMENT 201

Cut a piece of filter paper about 4–5 cm wide and the same length as the strips you used before. Dab various-colored felt-tip pens on the

starting line about 1 cm apart, once again about 1 cm from the bottom edge of the strip. Suspend the paper in the jar as in Experiment 200. Here too, the colors running in their various tracks will often reveal themselves as mixtures of different dyes. Just as in a real footrace, there will be slower and faster runners.



EXPERIMENT 202

Repeat the experiment with the water-alcohol mixture suggested in Experiment 200. You will be able to make some

interesting observations about which "runners" will move faster and which will move more slowly along the water-alcohol track.

EXPERIMENT 203

If you have a permanent marker available, you can study it in the same manner. If you use water, the starting spot will not move or hardly move at all.

EXPERIMENT 204

Repeat the experiment with the water-alcohol mixture. Now the spot will be "carried along" by the rising alcohol. If the color is a mix of dyes, here too there will be a more or less obvious decomposition of the color into various color zones.

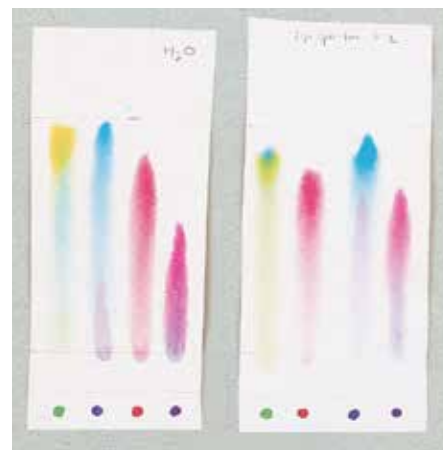

Race of the felt-tip pen colors (left water, right 4:3 water-alcohol mixture)

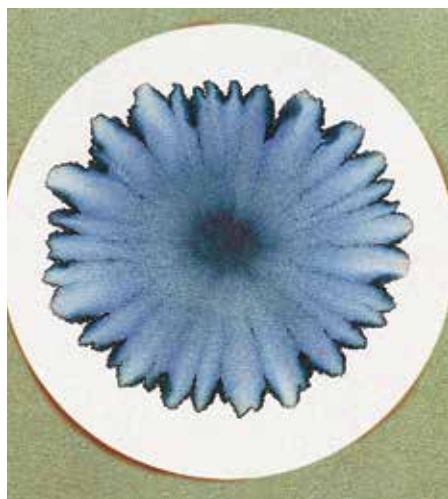

Simple Runge image made by dripping water or table salt solution onto a spot of ink.

Basic Knowledge



When colors write

The race of colors is decisively influenced by the filter paper and the type of "solvent" used (in your experiments, either water or the water-alcohol mixture). Dyes that easily dissolve in water will move almost as fast as the water itself. Dyes that don't dissolve so well in water will be left behind. Permanent dyes, which are practically insoluble in water, will be stuck at the starting gate. With the right solvent though, such as the water-alcohol mixture, you can even get the lazy ones moving right along.

The experiments you performed here are by no means mere child's play. Chemists use similar methods to decompose highly complex mixtures of materials into their component ingredients. They use special papers or plastic films coated in absorbent substances. They also have a lot of different solvents at their disposal. This work technique is known as **chromatography**. Inside this technical term, you will find the Greek roots *chromos* = color and *graphein* = writing.

You can also perform chromatography on mixtures of colorless materials if, after the race, you treat them with testing agents that show different characteristic colors for the individual components.

Pictures that paint themselves

The following experiments also involve a race of dyes, although the resulting pictures will look totally different.

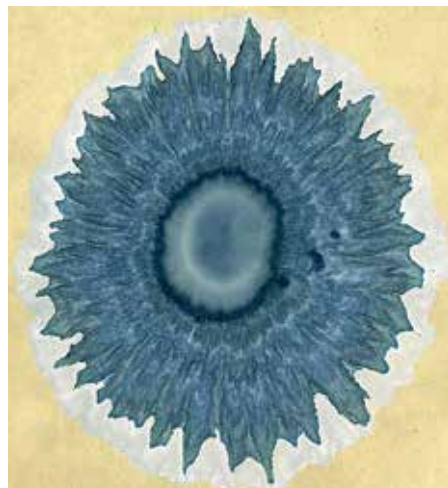

EXPERIMENT 205

Additional material: Black ink

Place a piece of filter paper on an upside-down lid or a small bowl. Use the pipette to add 1 drop of black ink to the center of the paper. The drop will run and form a circular ink spot. If you add another drop to the spot, it will expand farther outward. Keep adding drops of ink until the spot has a diameter of about 2 cm. You should always wait for the ink to soak into the paper before adding more though.

Now use the other pipette to drip water onto the center of the ink spot. Again, wait until the spot no longer looks wet before you add more.

In this way — simply by adding drops of water — you can get some really pretty pictures. It wouldn't be an easy task at all to paint or draw pictures like this with a pen or a brush.

EXPERIMENT 206

Repeat the previous experiment, but instead of water use a salt solution made by dissolving 1–2 spoonfuls of table salt in half a test tube of water. Compare the pictures you get against the others.

EXPERIMENT 207

Additional material: Water-soluble (washable) felt-tip pens

You can make similar pictures with the dyes contained in felt-tip pens too. Use the pen to paint a 1- to 2-cm-wide spot in the center of the filter paper. Develop the picture by dripping water or salt solution onto it.

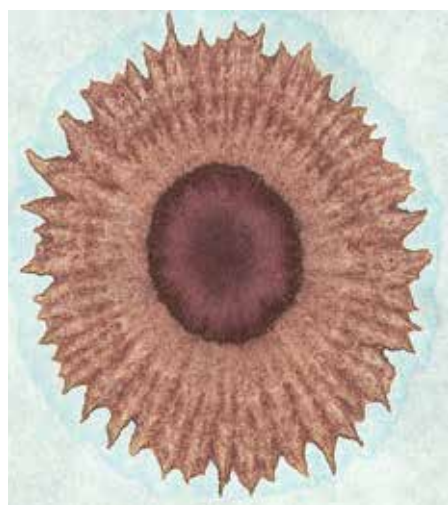

Two pictures made by following original recipes written by the discoverer of this "painting technique." In these cases, potassium hexacyanoferrate(II) solution acts on filter paper that was impregnated with iron sulfate or copper sulfate solution.

The discoverer of this “painting technique” was the chemist Friedlieb Ferdinand Runge (1794–1867). In 1855, he even published a book about his “autonomously-grown pictures.”

In the Runge pictures, the dyes radiate out in all directions along with the dripped-on liquid. In some cases, the intermediate stages are even more interesting than the final picture.

Circular chromatography

EXPERIMENT 208

Additional material: Purple felt-tip pen

You can also make round pictures with a special paper chromatography method known as *circular chromatography*. Use the purple pen to draw a spot about 3–4 cm in diameter on a piece of filter paper, lay the paper on an upside-down lid or small bowl, and drip water or table salt solution onto the center point of the circle. You will then be able to determine whether your purple is a single dye or a mixture of red and blue.

You can also try combining this procedure with the Runge method by applying a dye to the center of the filter after preparing and drying the circular chromatogram, and then making the dye spread out by adding water or table salt solution. There are a limitless number of things you can try in the field of paper chromatography.

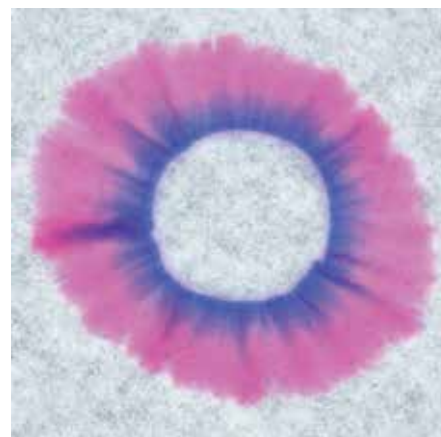
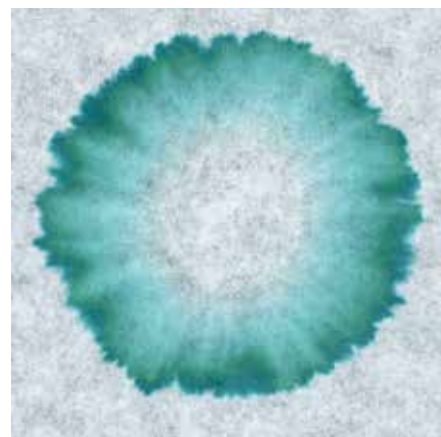
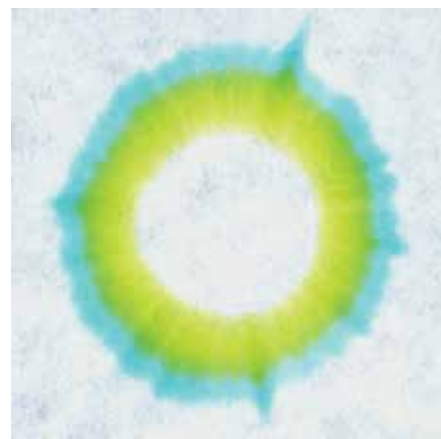

Circular chromatography



Question 43. How can you “paint” a blue circle 4–5 cm in diameter on a piece of filter paper without actually using any blue color?

For the remaining experiments, you will no longer be needing the potassium hexacyanoferrate(II) solution. Add 1 spoonful of copper sulfate to it and filter.

Brown precipitate: A6, filtrate: A4



A Runge image produced in several steps (photo: Dr. W. Botsch).

15

Sugar and Starch: Two Fattening Foods?



Sugar- and starch-containing foods.

There are people who live in constant fear of carbohydrates, avoiding “fattening foods” like pasta, cake, and sweets. Sugar and starch, however, are extremely valuable parts of the human diet. With sugars and starches, it’s all a matter of one common motto: everything in moderation.

Black carbon from white crystals

Ask an adult to help you with the next three experiments.

EXPERIMENT 209

Additional material: Aluminum foil as a work surface

Moisten some sugar with a few drops of water and heat it in an old but clean spoon. Wrap a rag around the spoon’s handle so you don’t burn your fingers. The sugar will melt and form a foamy yellow mass. Keep heating. The yellow mass will slowly turn brown and then get darker and darker. The vapor production will increase until the contents of the spoon suddenly burst into flame. It will even keep burning if you remove the spoon from the burner. Wait for the mass of sugar to stop burning. In the spoon, you will find a black, porous residue — carbon. **A3**

EXPERIMENT 210

Additional material: Pliers or metal tweezers, aluminum foil as a work surface, sugar cube, matches

Hold a piece of sugar with the pliers or metal tweezers and try to light it with a match. You probably won’t be able to do it. Rub a little cigarette or plant ash on the underside of the piece of sugar (see the tip on p. 86) and move the prepared spot toward a burning match. This time, you’ll definitely have better success. The piece of sugar will burn, and some of it will drip down. What’s left behind is black carbon. **A3**



Burning sugar



For **denatured alcohol**, note the “Hazardous substances and mixtures” information starting on p. 7. Have an adult helper pour 2 cm of the alcohol into a test tube for you.

EXPERIMENT 211

Additional material: Aluminum foil as a work surface, old dinner plate, some sand, denatured alcohol, powdered sugar, baking soda

Set the plate on the aluminum foil and pour a small pile of sand onto it (2 tablespoons). Mix 6 spoonfuls of sugar and 6 spoonfuls of baking soda in a test tube. Add 2–3 pipettes of alcohol to the sand pile and light the alcohol. Now, gradually sprinkle the sugar-soda mixture onto the fire. You will get little black balls that puff up. Usually, you will also get a somewhat larger, crumbly black monstrosity. It will keep growing as long as the fire burns. **A3**

The heat makes the sugar burn and melt. At the same time, the baking soda breaks down (as in Experiment 124) and releases carbon dioxide, which inflates the melting, burning sugar mass. Here too, you will be left with crumbly, almost weightless carbon.

Sugar will start to decompose at temperatures just a little above 200 °C, releasing flammable gases and leaving carbon behind. The fat, protein, and starch nutrients found in other foods will also decompose when heated, and all these nutrients contain carbon.

TIP
You can get long black “snakes” of carbon by placing a little pile of 2–3 spoonfuls of the sugar-baking soda mixture on the sand, wetting the sand with alcohol, and lighting. This trick has been around for a long time under the name “Pharaoh’s snakes.”



Basic Knowledge

Sugar from carbon and water?

The sugar you burned in the previous experiments belongs to a group called carbohydrates. Starch (Experiments 221–225) and cellulose (the “skeleton” of plants) are carbohydrates too. Carbohydrates contain the elements carbon, hydrogen, and oxygen. Sugar from the sugar bowl has the chemical formula $C_{12}H_{22}O_{11}$, while glucose (which you will be studying later) is $C_6H_{12}O_6$.

As you can see, there is a 2 : 1 ratio of hydrogen atoms (H) to oxygen atoms (O) (22 : 11 or 12 : 6). This is the same ratio as in water (H_2O_1). So you can think of the sugar molecule as built out of 12 C atoms and 11 H_2O molecules. And since the Greek root *hydro* was used in the learned language of the 19th century for water, the entire group of substances was named carbohydrates.

This name isn't quite right though. Carbohydrates don't actually contain any water molecules. So you can't make sugar or other carbohydrates by stirring together carbon and water.

Double sugar

For the following experiments, you will need to get some dextrose or glucose (in the form of little tablets, for example), which is popular with athletes because of its ability to supply quick energy. Glucose (or dextrose) is also available from stores as a white powder.

EXPERIMENT 212

Add equal quantities of powdered or pulverized glucose and sugar from the sugar

bowl, which we will call household sugar from now on, to two equal-sized drinking glasses and fill both glasses halfway with water. Stir well with a coffee spoon until all the sugar is dissolved, and taste the two sugar solutions. Which tastes sweeter?

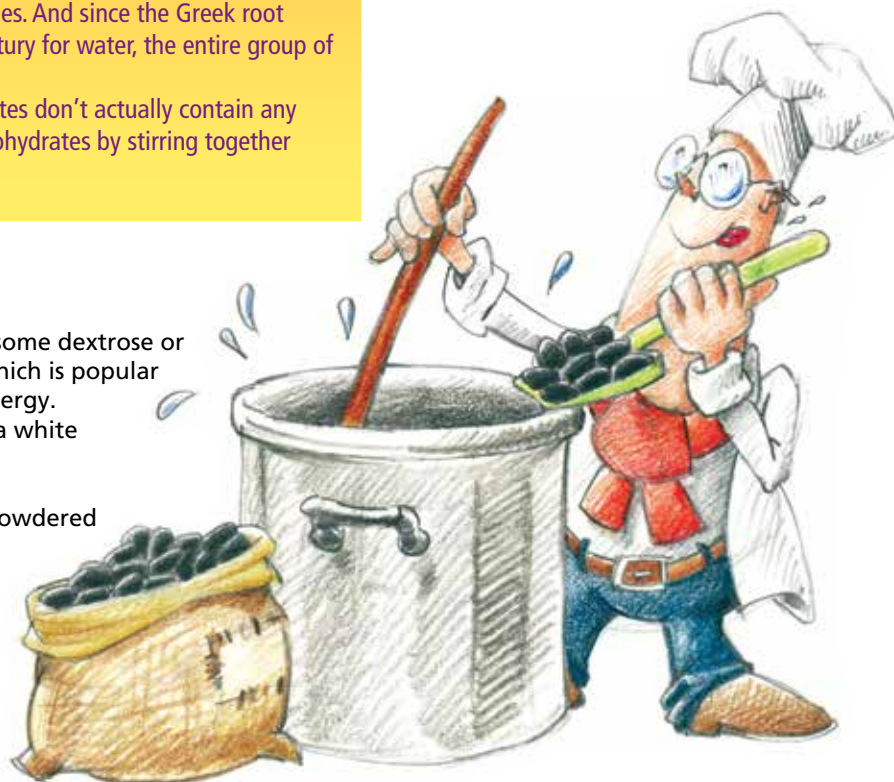

To be able to tell household sugar and glucose apart though, you don't have to rely on your tongue. Here too, the chemist knows some more precise and elegant testing techniques.



For **copper sulfate**, **citric acid**, and **sodium carbonate**, note the “Hazardous substances and mixtures” information starting on p. 7.

EXPERIMENT 213

Dissolve 1 small spoonful of copper sulfate and an equal quantity of citric acid in a test tube with 2 cm of water and shake well until everything is dissolved. In a second test tube, produce a not-too-weak sodium carbonate solution (2 spoonfuls in 2 cm of water). Now slowly pour the sodium carbonate solution over the copper sulfate-citric acid mixture. Don't be too skimpy with the sodium carbonate, but also don't add everything all at once. The test tube contents will turn darker. When the foaming stops, the solution will be dark blue. Your **glucose testing agent** is ready.



Glucose in natural and concentrated form



Question 44. Why shouldn't you add all the sodium carbonate solution at once?



Andreas Marggraf, the discoverer of beet sugar (photo: German Chemical Society).

TECHNOLOGY AND ENVIRONMENT



Cane and beet sugar

When you're talking about sugar, you usually mean the kind of cane sugar or beet sugar found in your kitchen, which are chemically one and the same thing. Sugar cane originally comes from Southeast Asia, from where it found its way to India long ago. It was the Indians who figured out how to make a honey-like substance from the juice of the sugar cane stalk. The West first came into contact with sugar during the time of the Crusades. Columbus brought sugar cane to America, where it was widely planted.

In the middle of the 18th century, the chemist Andreas Sigismund Marggraf discovered

sugar in the juice of the beet plant. This discovery gained importance when Napoleon imposed a continental blockade on the import of English goods from overseas, which encouraged the planting of beets along with the construction of sugar beet factories.

Since the 1930s, beet sugar production has experienced a significant increase. In 1996, there were 125 million tons of sugar produced worldwide, but just 116.8 million tons were consumed (due to reduced consumption in the Western industrialized countries). So people have been looking for new ways to use the overproduction, such as by processing it into alcohol to be used as biofuel.

Basis Information



Mr. Fehling's solution

The dark blue test solution is actually not a testing agent just for glucose, since several other sugars, such as fructose and lactose, also show the red precipitate. Since this involves a reduction, the sugar that causes this reaction is called a **reducing sugar**. The conversion of blue copper sulfate into red copper(I) oxide as a test for reducing substances was discovered by Hermann von Fehling (1812–1885). The blue testing solution is called **Fehling's solution**. The solution that you are using deviates a little from the "original recipe" though (use of sodium carbonate instead of highly caustic lye).



For the experiments with the glucose testing agent, called **Fehling's solution** in the following experiments (see info on the left), you will always have to use the boiling rod and be careful not to spray yourself or anyone else in the face or on the hands. Of course, you have to wear the safety glasses as well.

EXPERIMENT 214

Place 1–2 cm Fehling's solution in a test tube and add some glucose solution. Insert the boiling rod and heat! The contents of the test tube will first turn green, then yellow and finally brick red to reddish brown. **A6**

EXPERIMENT 215

Repeat the experiment, but instead of glucose use household sugar. This time, you won't get a red color. **A5**

Test for glucose with Fehling's solution



Glucose and household sugar — sucrose in technical terms — seem to be two different substances, as we can see by the different responses of the Fehling's solution.

Glucose — not just in fruit

Glucose gets its name from the Greek word for "sweet wine," and it is indeed found in wine grapes. But you can also find it in other places.

EXPERIMENT 216

Additional material: Grapes
Squeeze the juice from a few grapes and add the juice to 2 cm of Fehling's solution in a test tube. When you heat it (note the safety information before Experiment 214!), you will get the red precipitate typical of glucose. **A6**

EXPERIMENT 217

Additional material: Apple

You can even detect glucose in a sour apple. Squeeze a few apple slices and drip a little of the "apple juice" into 2 cm of Fehling's solution. Add a little more sodium carbonate solution to it as well (the solution has to have an alkaline reaction) and heat (note the safety information before Experiment 214!). A6

The glucose content in a sour apple is low, with any sweet flavor concealed by the high levels of acid in it. We can't rely on our tongues here, but we can rely on our chemical testing agent, which can detect even low levels of glucose. You can investigate other kinds of fruits and vegetables in the same way, along with fruit juices. You will find glucose in many things.

Sugar syrup and natural honey



For **citric acid**, **copper sulfate** and **sodium carbonate**, note the "Hazardous substances and mixtures" information starting on p. 7.

EXPERIMENT 218

In a test tube, add a few crystals of citric acid to some household sugar solution, insert the boiling rod, and heat for 3–4 minutes.

Test a few drops of the solution with Fehling's solution. This time, the contents of the test tube will turn red! A6

If you heat sucrose and acids — which act to accelerate the reaction — you will get a mixture of glucose and **fructose** (fruit sugar) with absorption of water:

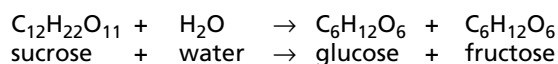

Glucose and fructose have the same composition, and thus the same formula, but differently constructed molecules, and therefore different properties.

EXPERIMENT 219

Recipes

If it sounds like fun to you to make an effervescent powder yourself, use baking soda and citric acid from unopened, clean packets. You shouldn't use substances that have already been used for previous experiments, since they might have come into contact with other chemicals. Work in the kitchen with kitchenware and utensils.

In a clean drinking glass, mix one-half teaspoon each of baking soda and citric acid with 1 teaspoon of sugar and fill the glass up with water. You can drink this homemade soda pop. Well, how does it taste?

Instead of sugar, you can use fruit syrup for sweetening; then you'll have a fizzy drink with pizzazz and taste. Pour 1–2 cm of fruit syrup into a drinking glass, fill the glass with water and stir well. Now you pour this diluted syrup into a drinking glass with a mixture of one-half teaspoon each of baking soda and citric acid. Homemade soda pop — the hit of your next birthday party!

EXPERIMENT 220

Additional material: Natural honey

Add 2–3 cm water to some honey in a test tube, and shake until the honey is dissolved. Test this honey-water with Fehling's solution. A6

Natural honey also consists of glucose and fructose. It has about the same composition as invert sugar syrup, and therefore the same nutritional value as well. The biological value of natural honey is due to the presence of certain active ingredients in it.

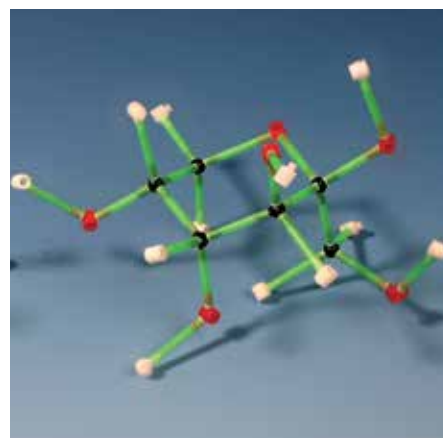
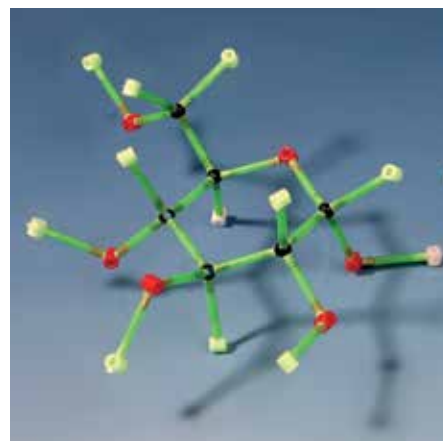

Ball-and-stick models of glucose (top) and fructose: carbon atoms are black, oxygen atoms are red, and hydrogen atoms are white



Natural honey consists of glucose and fructose too.



The blue iodine-starch solution loses its color when heated; when cooled, the blue color comes back.



Iodine brings starch to light.



There's a lot of starch in corn.

Potatoes or pasta...

... is basically a matter of taste, but also an indication that an important nutrient, starch, can present itself in very different ways. In order to look into it a little more closely, you will be using a well-known testing procedure: the iodine reaction for starch.



For **iodine**, note the "Hazardous substances and mixtures" information starting on p. 7.

EXPERIMENT 221

Additional material for this and the following experiments: Iodine solution and vitamin C tablets

Add 1 spoon tip of flour to a test tube half-filled with water, seal the test tube, and shake. Insert the boiling rod and heat until the liquid starts to boil. Be careful not to let it boil over: take the test tube away from the flame in time! Filter the still-hot liquid into another test tube. Dilute 1 cm of the filtrate (save the rest for Experiment 223) with three times the quantity of water, and add 1 drop iodine solution: deep blue color.

EXPERIMENT 222

Set the boiling rod in the blue liquid and heat. The blue will turn paler. Stop heating as soon as the blue has completely disappeared. Place the test tube in a screw-top jar holding 2 cm of cold water. The blue color will return, but only in the lower part. You will see a clear boundary between the cooled and the still-warm part of the test tube. Add vitamin C solution to the test tube. **A1**

Starch forms a deep blue compound with iodine, which can be used as a test for starch or for iodine. The iodine-starch compound is sensitive to heat. The reaction can be reversed though, so the blue color will return after cooling. Vitamin C will de-color not just brown iodine, but the blue iodine-starch compound as well.

Extra experiment: First produce a diluted iodine solution by adding 10 drops of the other solution to a test tube half-filled with water. Use the diluted solution (a few drops will do) to test for starch in bread, cooked potatoes, starch paste, pudding powder, and powders and other cosmetics. Afterwards, de-color the iodine-starch compound with vitamin C solution. **A1, A3**

Splitting starch



For **copper sulfate, citric acid, sodium carbonate, and sodium hydrogen sulfate**, note the "Hazardous substances and mixtures" information starting on p. 7.

EXPERIMENT 223

Prepare some Fehling's solution following the instructions provided in Experiment 213. Add a few drops of the starch solution you set aside to one third of this solution (save the rest for Experiments 224 and 225), and heat (insert boiling rod!). The starch solution won't show the characteristic red precipitate. **A5**

EXPERIMENT 224

In a test tube, heat 1 small spoonful of flour and 2 spoonfuls of sodium hydrogen sulfate with 2 cm of water (use the boiling rod!). The liquid will foam up, so you will have to keep pulling the test tube away from the flame to keep it from boiling over. Heat until there is only 1 cm of liquid in the test tube. Add ½ cm of water to a graduated beaker and pour in the still-hot contents of the test tube. Add 3–4 spoonfuls of sodium carbonate and wait for the foaming (caused by escaping carbon dioxide) to stop. Now add the contents of the graduated beaker and the second

Basic Knowledge



On giant molecules

In Experiments 224 and 225, you created glucose by splitting starch. Starch is made of giant molecules, so-called **macromolecules** (Greek *macros* = long, large). These giant molecules are constructed from glucose molecules that are lined up alongside each other or inter-meshed. In this parallel or inter-meshed arrangement, one H atom and one OH group are split off from each glucose molecule, with the resulting glucose "residues" connected by oxygen bridges. One starch molecule contains from 1,000 to 100,000 glucose residues. The glucose residues connected in this way do not react like normal glucose molecules. So starch cannot reduce the Fehling's solution to red copper(I) oxide. When starch is split, the exact opposite happens: H_2O molecules push between the glucose residues, split into H atoms and OH groups, and join the "residues" to form complete glucose molecules that respond to the Fehling's solution. The splitting can be achieved by a strong acid in a test tube, but also by enzymes contained in saliva, which start the process of starch digestion. The walls of your digestive tract can only absorb the relatively small glucose molecules, not the giant starch molecules.



The chemist Hermann Staudinger (1881–1965) received the Nobel Prize in 1952 for his research into the structure of macromolecular materials (photo: German Chemical Society).

third of the Fehling's solution from Experiment 223 to a test tube and heat (use the boiling rod!). The test tube contents will first turn green. As you continue heating, the red precipitate characteristic of reducing sugar will appear. **A6**

EXPERIMENT 225

Chew a piece of bread (no cookies or cake!) thoroughly for a long time, put the bread-saliva mixture in a graduated beaker, and then use the double-headed measuring spoon to transfer it to a test tube. Heat the mixture with the rest of the Fehling's solution (use the boiling rod!). You will observe the familiar red color, or at least yellow. If you use too much Fehling's solution, you will only get a green precipitate. **A6**



Question 45. In the last experiment, why were you not supposed to chew cake or cookies?

How starch molecules are formed from linked-up glucose molecules. Each glucose molecule (represented in simplified form) has 2 OH groups, from which 1 molecule of water (H_2O) is split off. The remaining oxygen atoms (O) create the connection between the links in the chain. When starch is split, the reaction runs in the opposite direction: splitting of H_2O molecules and attachment of the OH group and the H atom to the glucose residues. The starch molecules, by the way, do not form "stretched threads" — instead, they have the shape of a "spiral staircase."

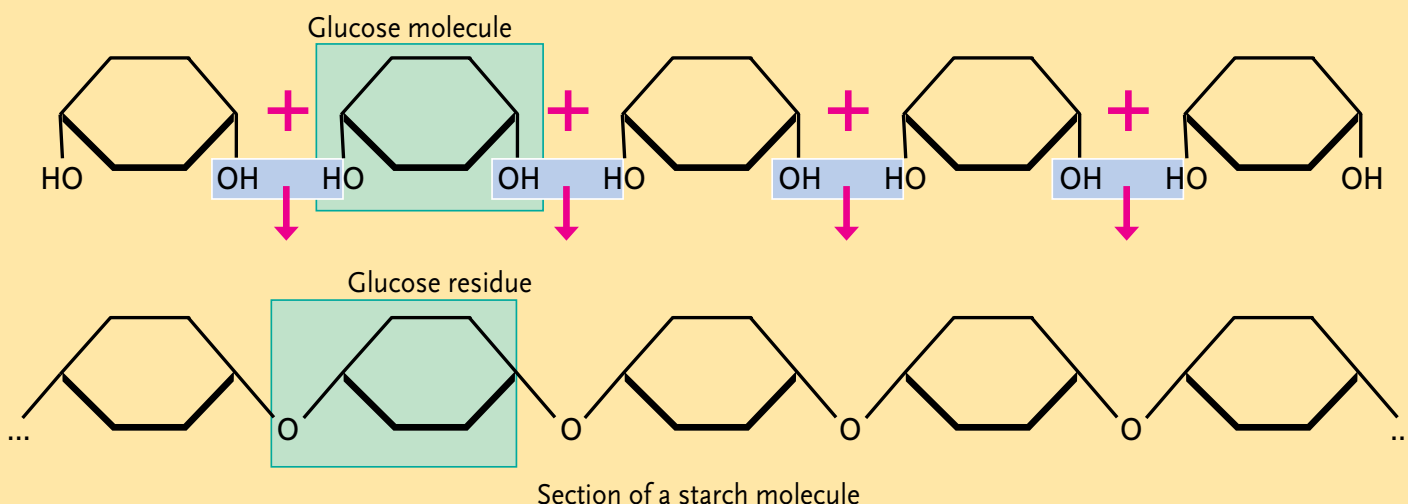

16

Protein: Not just in Chicken Eggs



Do you know how to crack open a raw egg without breaking the yolk? If not, someone can probably show you how to get the hang of it. Let the jelly-like substance surrounding the yolk, the **egg white**, run into a graduated beaker. Dispose of the egg following the experiments.

The egg white coagulates



For **copper sulfate**, note the "Hazardous substances and mixtures" information starting on p. 7.

EXPERIMENT 226

Ask an adult to help you with this experiment. Place 1 cm of egg white in a test tube and hold the test tube in a pot of hot water shortly after bringing it to boiling. The egg white will turn solid — it coagulates. Only now is it actually white. Save the contents of the test tube for Experiments 228 and 229.

The same thing happened to the egg white as happens when you boil an egg. It makes no difference whether it is heated in the test tube or in the shell.

EXPERIMENT 227

Dilute a little raw egg white with 10 times the amount of water. Add a few drops of copper sulfate solution to 3–4 cm of the diluted solution in a test tube. You will get a thick precipitate that turns a bluish color from the copper sulfate. Save the rest of the diluted egg white for Experiment 230. **Leftover copper sulfate solution: A4, other residues: A1, A3**

Copper sulfate makes egg whites coagulate too. The same applies to other heavy metal salts, such as lead, cadmium, or mercury salts. The toxic effect of these substances comes from the fact that the life-essential proteins in the body cannot function in a coagulated state.

Protein



When you think of protein, you probably first think of eggs, meat, and milk. But protein also appears in a lot of plant products. You yourself, in fact, consist for the most part of proteins, once we set aside water. Protein is the foundation of all plant and animal life, which is in fact where the name protein comes from. In Greek, *proton* means "the first" or "most important."

Proteins can form very large molecules too. The building blocks of proteins are amino acids. While starch molecules consist of nothing but identical glucose residues,

the amino acids in a protein molecule form a colorfully mixed assortment.

Proteins in a narrow sense refer to macromolecules with more than 100 amino acids. Protein molecules with 2 to 100 amino acids are referred to as peptides.

In contrast to sugar and starch, the basic role of protein is not as an energy source, but as a building block for the body. Proteins are essential components of a variety of bodily tissues and, as enzymes and peptide hormones (such as insulin), they regulate metabolic processes.

Protein-containing foods

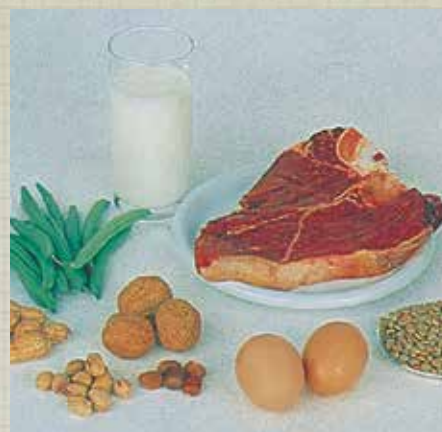

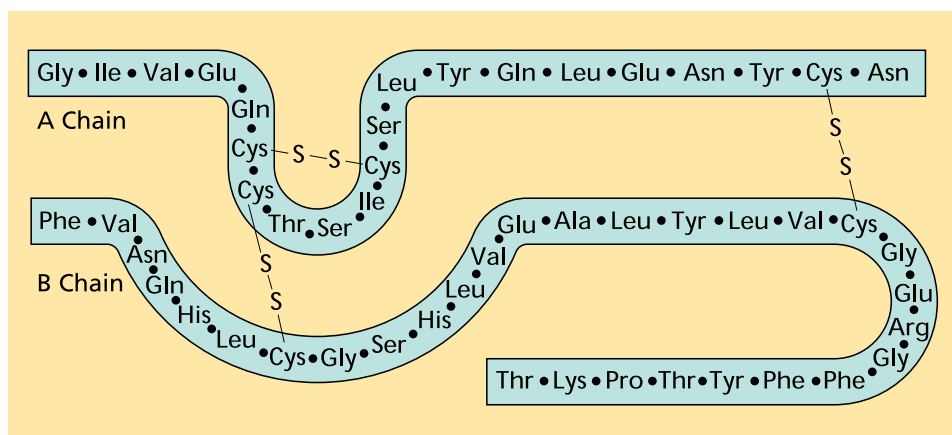

Schematic representation of the insulin molecule. Every three-letter combination is an abbreviation for an amino acid (e.g., Gly for glycine = aminoacetic acid).

Getting in on the party: nitrogen



For **calcium hydroxide** and **sodium carbonate**, note the “Hazardous substances and mixtures” information starting on p. 7.

EXPERIMENT 228

Place a little of the coagulated egg white from Experiment 226 onto the small end of the double-headed measuring spoon or onto an eyelet made from a wire.

Hold the egg white in the burner flame. It will get fried to a crisp and turn black. At the same time, you will notice a strange smell that is nothing like what you would smell if you burned paper or cotton. **A1, A3**



Silk is made of protein made from the webs of various animals. The most important is the mulberry silk made by the mulberry silkworm moth.



Question 46. What does the smell remind you of?

EXPERIMENT 229

To the rest of the coagulated egg white from Experiment 226, add 1 spoonful of calcium hydroxide, 1 spoonful of sodium carbonate, and a few drops of water. Get a piece of anthocyanin paper and a piece of red litmus paper ready and moisten the test strips. Heat the test tube and test the escaping vapors with the strips. They will show an alkaline reaction. The only possible gas that will have an alkaline reaction with water is nitrogen-containing ammonia (NH_3). Stop heating as soon as the test papers have turned color. The test tube will be easier to clean if the egg white has not become completely carbonized.

A1, A3

There's another well-known test that relies on the nitrogen content of proteins: the biuret reaction.

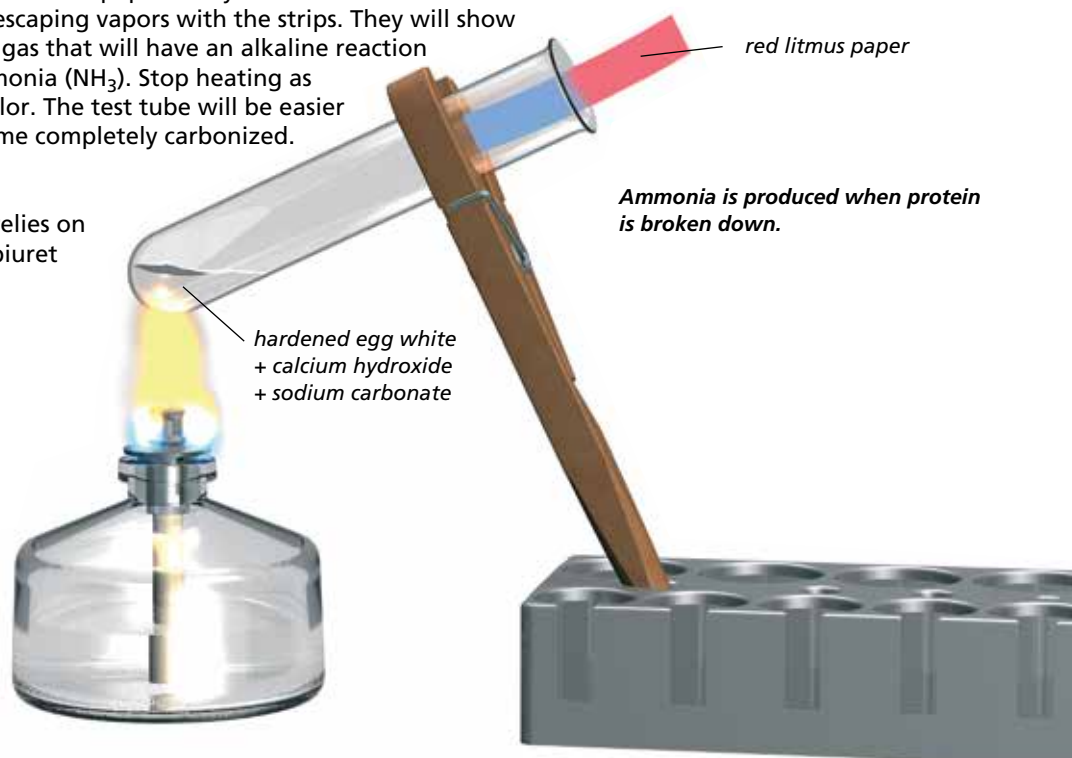

Ammonia is produced when protein is broken down.



EXPERIMENT 230

Place 3–4 cm of the diluted egg white solution from Experiment 227 in a test tube. Add 1 spoonful of sodium carbonate, seal the test tube with the stopper (thumb on top!), and shake. Treat the test tube contents with 2–3 drops of copper sulfate solution (dissolve 1 spoonful of copper sulfate in 3 cm of water). No, instead of a precipitate of coagulated protein as in Experiment 227, you will gradually get a purple-colored solution. **Reaction product: A1, leftover copper sulfate solution: A4**

This test reaction is named after biuret, a substance that shows the same purple color with copper sulfate in an alkaline solution.



Basic Knowledge

Amino acids — building blocks of protein

While proteins contain just 20 different amino acids, there is a practically limitless number of ways of combining these building blocks in protein macromolecules.

In addition to carbon, hydrogen, and oxygen — the elements in carbohydrates — amino acids contain the element **nitrogen**, and two amino acids also contain the element **sulfur**. The fact that proteins differ from carbohydrates in their makeup is evident from the burn test (Experiment 228). If the smell reminds you of burning hair, that's no coincidence. Hair, nails, horns, claws, and hooves belong to group of keratins (Greek *keras* = horn), a subcategory of proteins. A characteristic component of the amino acids is the **amino group** ($-\text{NH}_2$), which consists, as its formula shows, of 1 nitrogen atom and 2 hydrogen atoms.

The simplest amino acid is aminoacetic acid. The illustration shows how aminoacetic acid is created from acetic acid by the replacement of an H atom with the NH_2 group.

When the amino acids are connected to the protein or peptide molecule, the NH_2 groups react with the COOH groups characteristic of organic acids: As water is split off, just as with starch, the building blocks — the amino acids — are connected up to form a macromolecule.

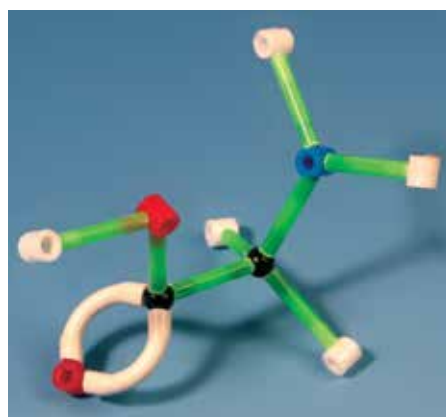
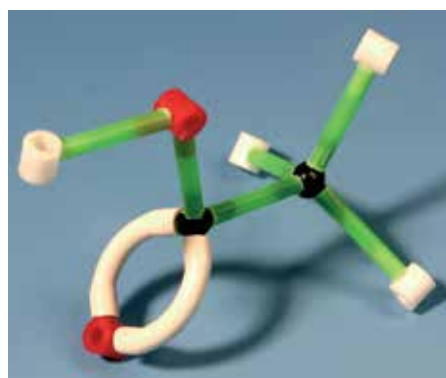

Molecule models of acetic acid (top) and aminoacetic acid. A hydrogen atom from acetic acid (white) is replaced with the NH_2 group (nitrogen atom is blue).

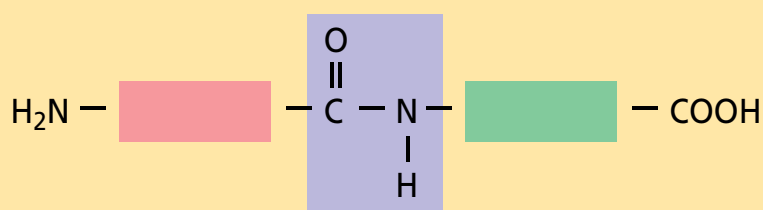
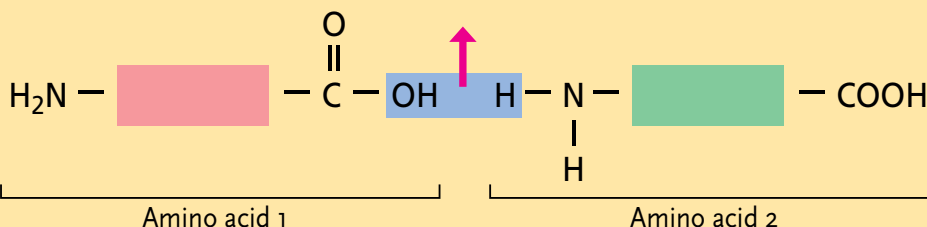

This group and Cu ions bring about the purple color in the biuret reaction

The amino acids are built in different ways, but all have a COOH group and an amino group ($-\text{NH}_2$). If these groups meet up, the linking-up of amino acids can occur under the elimination of water.

EXPERIMENT 231

Additional material: Raw meat

Chop up a small piece of raw meat (or use hamburger meat) and shake it with half a test tube of water.

Separate out the chopped meat from the clear "meat water" by filtering. Heat one half of the meat water over the burner flame. You will observe a thick, white cloudiness. **A1, A3**



For **sodium carbonate** and **copper sulfate**, note the "Hazardous substances and mixtures" information starting on p. 7.

EXPERIMENT 232

Carry out the biuret test (as in Experiment 230) with the other half of the meat water. You will observe a purple color that gradually gets stronger and stronger. **Leftover**

copper sulfate solution: A4, reaction product: A1, A3

Everything contained in milk

If you left fresh, untreated milk to sit for a few days in the refrigerator, a thick mass would settle on its surface: cream. Cream contains about a quarter fat, which is normally distributed in microscopically small spheres throughout the milk. When the milk is left to stand, the lighter fat rises to the top. From the cream, you can make butter. The milk you buy in the store is almost always homogenized, meaning that the fat is dispersed so finely that the cream won't rise. This kind of even distribution of materials that don't actually mix is known as an emulsion (Latin *emulgere* = to milk; milk, as the most familiar emulsion, gave its name to this kind of mixture). For the following experiments, it is best to use low-fat milk from the store (1% fat). The biuret reaction will show that milk contains protein.

EXPERIMENT 233

Shake 2 cm of milk with 1 spoonful of sodium carbonate in a test tube, and add 2–3 drops of copper sulfate solution (dissolve 1 spoonful of copper sulfate solution in 3 cm water). The test will also work with whole milk (about 3.5% fat), but the purple color will be somewhat weaker. **Disposal as in Experiment 232**

You can even precipitate out the milk protein and filter it.

EXPERIMENT 234

Additional material: Small cloth, rubber band

Fill a test tube halfway with low-fat milk and heat the test tube over the burner flame. Just don't let the milk boil! Now add some vinegar to the test tube: The milk will coagulate into a flaky precipitate. The same process is involved here as when milk goes sour. The souring of milk is caused by lactic acid, and happens because of the activity of lactic acid bacteria. As you see, the curdling process can also be triggered by other acids, such as acetic acid.

To filter off the precipitate, you won't be using filter paper this time; instead, use an old but clean cloth rag, such as a well-used cloth handkerchief. Lay the "filter cloth" over the screw-top jar and secure it with a rubber band. Now pour the contents of the test tube little by little over the filter cloth. Save the filtrate in the container (the whey) for the next experiment. Squeeze out the residue that remains behind in the filter cloth and let it dry. The yellowish, slowly hardening mass consists mainly of a protein contained in milk called casein. The name, which comes from the Latin for "cheese," indicates that casein, along with water and fat, is the main ingredient in cheese. When making cheese, you proceed similarly to this experiment. But instead of adding acetic acid to the milk, you add some of the rennet present in cows' stomachs. Depending on the fat content of the milk used, you end up with low-fat or high-fat cheese.



Milk is healthy



Cheese production — more than just casein coagulation

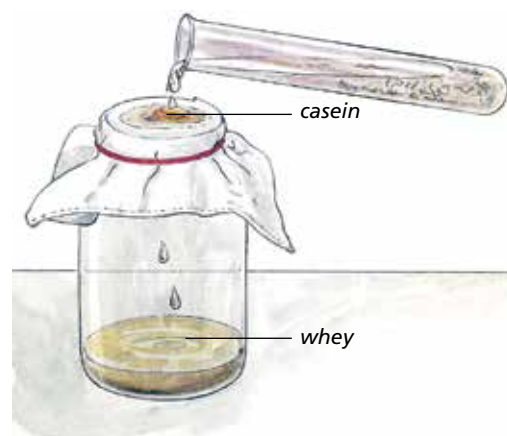

Filtering off the casein precipitate from milk



Humans need about 1 g of protein per kilo of body weight each day. An adult weighing 75 kg, in other words, would need 75 g. The illustrations show various food quantities containing 75 g of protein.



For **copper sulfate**, **citric acid**, and **sodium carbonate**, note the "Hazardous substances and mixtures" information starting on p. 7.

EXPERIMENT 235

Measure 2–3 cm of the whey you got in the last experiment into a test tube and add sodium carbonate solution to neutralize the added acetic acid. The test tube contents must have an alkaline reaction (for example, turning anthocyanin paper green). Now prepare the blue Fehling's solution as in Experiment 213. Heat 2–3 cm of Fehling's solution with the same quantity of neutralized whey (insert the boiling rod!). You will observe the familiar red coloring. **A6**

In this case, the red color comes from the lactose (milk sugar) contained in the whey. Lactose reacts to the copper sulfate-citric acid solution similarly to glucose and fructose.

Your investigations have yielded the result that milk contains fat, protein, and sugar — in other words, all important nutrients. On top of that, you can find life-essential minerals and vitamins in milk. Now you understand how baby animals and humans can survive on nothing but milk.

TECHNOLOGY AND ENVIRONMENT



How much protein do humans need?

There is one respect in which plants have a definite upper hand over animals and humans: They are able to produce all the amino acids they need. Humans and animals can do that with only a few of the amino acids. So they have to supply themselves protein in their diet in order to be able to build the protein their bodies need. An adult human needs almost 1 gram of protein per kilogram of body weight each day.

Protein deficiency — most common among children in economically underdeveloped countries — can lead to serious, sometimes life-threatening, diseases.

In view of the fact that conventional plant and animal

protein sources will no longer be sufficient for the nutritional needs of humans in the foreseeable future, researchers are working on finding new, unconventional methods of producing protein. For example, protein can be made by the fermentation of sugar and nitrogen-containing nutritional salts. Cellulose, molasses (a by-product of sugar production), and other waste products can also be used as raw materials. Proteins obtained in this way might be primarily used as animal feed, and thus be available for human consumption after taking a detour through animal protein. Proteins that are suitable for direct consumption by humans can be obtained from soy beans, sunflowers, rapeseed, lupines, and other plants.

17

Water, Fats, and Surfactants

Cleaning products play an important role in the sorts of daily cleaning tasks you have to do around the house. That starts with washing your hands and continues through doing loads of laundry and goes all the way to special cleaners for all kinds of specific purposes. Take a look around in your kitchen, bathroom, basement or garage and see what you can find.

For the following experiments, you will need solid and liquid soap as well as dishwashing liquid. Of course, washing also requires water. So you will first learn about a special quality that water has.

Water has a skin

EXPERIMENT 236

Place a graduated beaker in the basin and fill it to the rim with water. Now let some more water flow slowly into it from a test tube. You will be amazed how much more water the beaker can still take without overflowing. Take a look at the beaker from the side. The water surface will be bulging upward. It looks as if the water had a skin stretched over it, holding it in place and keeping it from overflowing.

For this and the following experiments, dissolve a little finely-shaved soap in half a test tube of water. Then, as you watch the beaker from the side, add 1 drop of the soap solution to the water's surface. The mound of water will collapse, and water will flow over the edge.

Repeat the experiment with liquid soap or dishwashing liquid.

EXPERIMENT 237

Thoroughly clean the basin, then fill it with water and carefully place a sewing needle on the surface. Don't give up if it doesn't work right away. If it doesn't work the second time, place the needle on a little bit of paper towel. The paper will absorb water and then sink. The needle will remain floating on the water, even though the steel that it is made of is much heavier than water. If you look carefully, you will see that the needle has sunk a little into the water. It really does look like an expandable skin is preventing the needle from sinking. Add a few drops of soap solution to the water. Within a few seconds, the needle will sink. A drop of liquid soap or dishwashing liquid will work even faster.



Question 47. What might the reason be if the needle won't float, but sinks right away?

EXPERIMENT 238

Additional material: Various pieces of cloth

Place 1 drop of water on various pieces of cloth with the dropper pipette. Particularly if it's a new piece of cloth, the water may hold its round shape and not sink into the fabric. Repeat the experiment with 1 drop of soap solution or dishwashing liquid. The drop will dissolve and penetrate the fabric.

Water does in fact behave as if there were a skin stretched over its surface. If you place light objects on the water, they will make a little dent in the surface. This phenomenon is known as surface tension. It also accounts for the fact that small quantities of water will take the form of droplets and won't really wet the underlying fabric properly. See the "Basic Knowledge: Surfactants break tension and emulsify" section to see how soaps can get rid of or reduce surface tension.



Washing and cleaning products



Does water have a skin?



The floating sewing needle

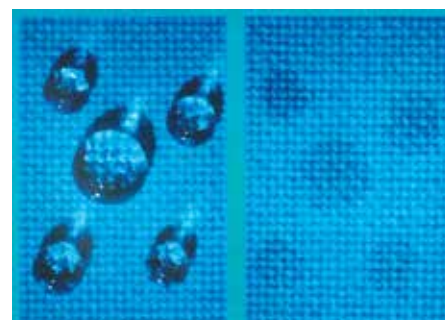

Water beading on fabric. Soap or dishwashing liquid will help ensure adequate wetting.

Water and fat, two arch-rivals

Why is it that fat will float in little oily droplets on the surface of a bowl of soup? Right, because it's lighter than water and because it doesn't mix with water. Oil and water just don't get along.

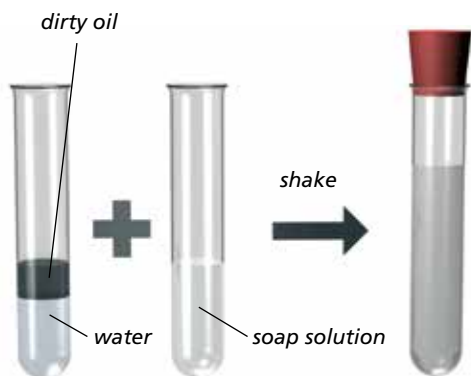

Soap solution emulsifies oil.

EXPERIMENT 239

Additional material: Cooking oil

Fill a test tube halfway with water and add some cooking oil. The lighter oil will float on top of the water. Seal the test tube with the rubber stopper and shake vigorously. The oil will spread out in the water at least temporarily, but it will soon rise up in little droplets to the water's surface again. Water and oil repel each other. **A1**

EXPERIMENT 240

Additional material: Cooking oil, dust or carbon powder (from burned wooden matches or scratched off a pencil lead)

Make a layer of oil on top of some water as in the previous experiment. Add a little dust or carbon powder to the test tube and shake vigorously! The oil droplets or the resulting layer of oil will turn gray to black, while the water remains clear. Save the mixture for the next experiment. Apparently, oil (or fat) has a special attraction to dirt. **A1**

EXPERIMENT 241

Add some soap solution or dishwashing liquid to the test tube with the dirty oil. Shake vigorously! This time, the water and oil won't separate so quickly. The entire test

tube contents will turn a dirty gray. The fat, and the dirt along with it, has become dispersed throughout the water. You have created an emulsion. The emulsified, oily dirt can now be rinsed away along with the soap. **A1**

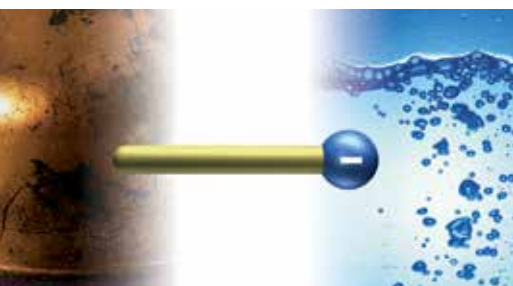

Surfactant ions — a good friend of water and fat

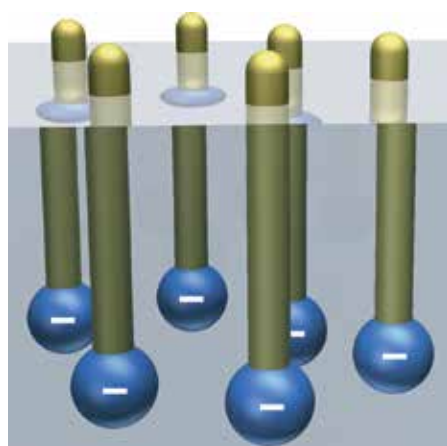

Surfactant ions "perforate" the water's surface.

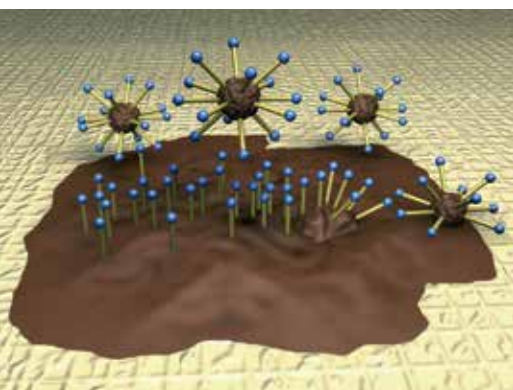

The surfactant ions cover the fabric to be cleaned, remove the fatty dirt, and surround the dirt particles with a negatively-charged envelope, which has a repelling effect on the other similarly-charged particles. The dirt is finely dispersed.

Basic Knowledge



Surfactants break tension and emulsify

Regardless of whether it's solid soaps (bar soaps), liquid soaps, or dishwashing liquids — your experiments show that these cleaning products do away with the surface tension of water and disperse oily dirt evenly in water. Materials that can accomplish this are called **surfactants** (from surface active agent).

The cleaning power of surfactants comes from the fact that they "get along" well with both oil and water. The active component of the surfactants that we're dealing with here are negatively-charged, rod-shaped ions. The shorter end of the rods (blue sphere) carries the negative charge, and is hydrophilic (literally, "water-loving"). The longer part of the rod is similar to the fatty acids in the oils, and it is lipophilic ("fat-loving"). If you add a surfactant to water, the ions will first collect on the water's surface. The hydrophilic end will stick down into the water, while the lipophilic end will stick up into the air. The forces of attraction between the water molecules on the water's surface will be reduced by the surfactant ions. The skin will become "perforated," and won't be able to support even light objects anymore, and water droplets won't be able to hold together any longer. That is the **surface tension-reducing effect** of surfactants.

In a water-and-oil mixture, the surfactant ions will wrap around fine oil droplets by turning their lipophilic end toward them. The oil droplets that are "broken down" in this way are negatively charged on the outside, and therefore repel each other. This ensures that the oil droplets are finely dispersed throughout the water. That is the **emulsifying effect** of surfactants.

In washing, surfactants work to ensure a better wetting of the material to be washed by reducing surface tension. The surfactant ions make contact with the oily dirt, remove it from the fabric to be cleaned, and emulsify it like the oil droplets, so it can be rinsed away along with the soapy water.

Hard water and soap scum

Up to now, you have learned about the common properties of surfactants. Now we'll take up a problem specific to conventional soap: its aversion to hard water.

In order to study the effect of hard water on soap, you will first need some "soft" water — the *distilled, purified, or demineralized water* available in drug stores or supermarkets. The term purified or demineralized is more correct here than distilled, since the water doesn't really have other materials removed from it by distillation as you did in Experiment 19; instead, the water to be softened is made to run across special synthetic resins. The resins bind the materials responsible for the water's hardness. This method for softening water requires a lot less energy than distillation. You might, in fact, already have a water softener in your home, maybe to make soft water for use in a traditional clothes iron.

EXPERIMENT 242

Additional material: Bar soap

Dissolve some fine soap shavings in purified water. Take enough soap solution to cover the bottom of a test tube, add it to half a test tube of purified water, and shake vigorously! You will get a lot of foam, which is an indication of the cleaning power of soap.

EXPERIMENT 243

Repeat the previous experiment, but instead of purified water, use ordinary tap water. Keep an eye on the foam!



For **calcium hydroxide** and **limewater**, note the "Hazardous substances and mixtures" information starting on p. 7.

EXPERIMENT 244

Additional material: Bar soap, sparkling water

Slowly add some fresh sparkling water to half a test tube of limewater. You will first get the familiar cloudiness that you know from the carbon dioxide test. If you keep adding sparkling water, the precipitate will dissolve (Experiment 137). You have made a calcium hydrogen carbonate solution. Add some of your soap solution to half a test tube of the clear solution and shake (thumb on top!). Instead of foam, all you will get is a flaky precipitate. **A1**

Solid soaps (bar soap or bath soap) contain fatty acids, which owe their name to the fact that they are components of fats. In soap production, the fatty acids bind to sodium hydroxide or sodium carbonate to form salts. You read it right: soaps are fatty-acid salts that decompose into sodium and fatty-acid ions in water. Fatty-acid ions form insoluble soap scum (the flaky precipitate in Experiment 244) with the calcium ions in hard water. The fatty acid ions are blocked, and can no longer do their "double duty" in the suds.

Tap water — as you learned in Chapter 10 — contains a certain amount of calcium hydrogen carbonate in addition to other salts. In most cases, its foam formation is therefore weaker than when you use purified water. These days, though, it's common to add softeners to bar and bath soaps, in order to avoid an unnecessary waste of soap. In those cases, the reduced foam formation with tap water is not so obvious. In the quantities used, these softeners can't do much against the hard water you used in Experiment 244.

Molecular model of a fatty acid (palmitic acid). If the H atom indicated by the arrow is split off as an H^+ atom, you get the negatively-charged fatty acid ion showing the surfactant structure: the short, hydrophilic end with the two oxygen atoms (red), and the long lipophilic chain of CH_2 links. The surfactant ions form water-soluble soap with sodium ions, or insoluble soap scum with calcium ions.

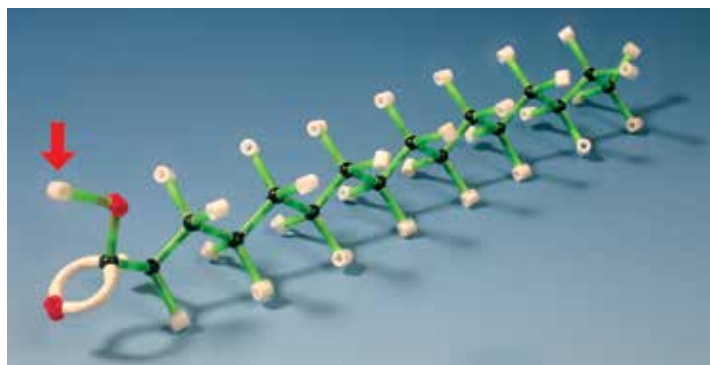

Side Notes

Soap — long known and loved

Soaps and soap-like products belong among the earliest cultural achievements of humanity. They were already known to the Sumerians in the third millennium BC, who cooked potash (potassium carbonate) together with plant oils. The Roman writer Pliny the Elder (23–79) reported that the Germanic and Gallic tribes also knew how to produce simple soaps. In post-medieval times in Florence and Marseille, there was a thriving soap industry.

Today, bar and bath soaps have lost some of their importance. Synthetic surfactants in liquid soaps are not only better at handling hard water, they are also provide gentler care for sensitive skin due to their neutral reaction in water-based solutions.

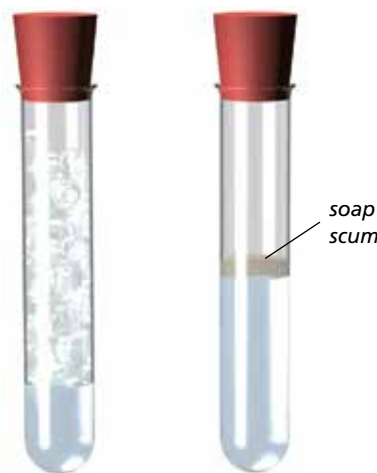

Soap solution with purified water (left) and hard water (right).



Softening by heating

Of course, long before the discovery of the new softeners, people were trying to find ways to deal with hard water.

EXPERIMENT 245

Additional material: Bar or bath soap, sparkling water

Make some hard water again as you did in Experiment 244. When you heat the solution, insoluble calcium carbonate (Experiment 138) will separate out. Add soap solution and shake! You will get foam. The insoluble calcium carbonate doesn't form soap scum. **A1**

Of course, tap water and well water don't just contain calcium hydrogen carbonate, they also have other salts that form insoluble substances — such as calcium sulfate, which you already got to know as plaster or gypsum.



Use only small quantities of **plaster**. Avoid breathing dust. – Do not get in eyes, in mouth or on skin. Do not ingest.

EXPERIMENT 246

Additional material: Plaster

Shake 1 spoonful of plaster with half a test tube of water. Wait until the undissolved plaster has settled to the bottom of the test tube, and pour the clear liquid above it into another test tube. The "gypsum water" you prepare in this way contains dissolved calcium sulfate. If you now shake gypsum water with soap solution, you will not get any foam, just soap scum. **A1**

You can't soften calcium sulfate-containing water just by heating it, but you can do it by adding washing soda, or sodium carbonate.



For **sodium carbonate**, note the "Hazardous substances and mixtures" information starting on p. 7.

EXPERIMENT 247

Add sodium carbonate solution to 3 cm of gypsum water and heat. You will observe the formation of a calcium carbonate precipitate. The sodium carbonate has converted the dissolved calcium sulfate (CaSO_4) into insoluble calcium carbonate (CaCO_3):

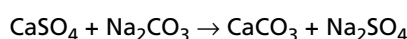

If you now add soap solution and shake, you will get foam. **A1**



Question 48. Why doesn't the calcium carbonate precipitate prevent foam formation?

The softening methods described here do have a disadvantage though, which is that calcium carbonate settles onto the wash. When modern washing products are used, such as the ones we will be dealing with in a moment, the softening process won't leave behind any insoluble residues.

Synthetic surfactants — immune to calcium carbonate and acid

Unlike the soaps made from fats, synthetic surfactants are used in modern liquid soaps, laundry detergents, and dishwashing liquids. The lipophilic part of the surfactant ions is built exactly like that of the soaps. The difference has to do with the hydrophilic, negatively-charged part of the ions.



Modern softeners can do more than washing soda could. They capture the harmful calcium ions and get rid of them — down the drain.



All the things contained in modern laundry detergents

EXPERIMENT 248

Additional material: Laundry detergent

Fill a test tube three quarters full of water and add 1–2 spoonfuls of laundry detergent. Shake vigorously to make everything dissolve (otherwise you will have to filter it). Now add some of your laundry detergent solution to half a test tube of calcium hydrogen carbonate solution, prepared in Experiment 244, and shake. As before, you will observe a strong foam formation. You won't see any soap scum-like precipitate. A test with gypsum water (prepared as in Experiment 246) will show the same result. Save the rest of the laundry detergent solution for Experiment 250.

The surfactant ions that are active in modern laundry detergents are derived from sulfuric acid. They won't form any insoluble soap scum with the calcium ions in hard water, so they can fulfill their tension-reducing and emulsifying function without any hindrance.

EXPERIMENT 249

Additional material: Bar or bath soap

Add some vinegar to a test tube of soap solution. There will be a noticeable cloudiness. When you shake it, flakes will form and rise to the surface. You might think that this is the same thing as the soap scum. **A1**



Question 49. Why isn't it possible for this to be soap scum?

EXPERIMENT 250

Add some vinegar to the rest of the laundry detergent. Unlike in Experiment 249, no precipitate will form. **A1**

The fatty acids processed in bar and bath soap are weak acids that are practically insoluble in a water solution. If there is a sudden excess of hydrogen ions in a soap solution (because you added vinegar), the fatty acid ions unite with the hydrogen ions to form insoluble fatty acids that have no cleaning power, but would be more likely to smudge the laundry.

Synthetic surfactants are salts of strong acids, and they are very water-soluble. The negatively-charged ions move around very freely in the laundry suds and are thus very effective in the wash.

Regular or mild detergent

If you wanted to get rid of fruit or red wine stains, it used to be that you would use chlorine-containing compounds. But chlorine bleach was hard on the wash, and polluted the water system with harmful substances. Today, oxygen bleaches are the thing to use.



For **potassium permanganate**, **sodium hydrogen sulfate**, and **hydrogen peroxide**, note the "Hazardous substances and mixtures" information starting on p. 7.

EXPERIMENT 251

Additional material: Hydrogen peroxide

Add 1 spoon tip of potassium permanganate mixture and 1 spoon tip of sodium hydrogen sulfate to a test tube full of water. Divide the solution among three test tubes. Add some hydrogen peroxide solution to the first test tube. The purple color will disappear. The loss of color serves as a test for hydrogen peroxide. **A8**



Only with a soap solution will adding acid result in an insoluble precipitate (left), not with synthetic surfactants (right).

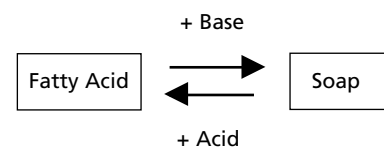

A mild and a regular detergent



Calcium deposits on the heating elements of a washing machine (photo: Benckiser)



Algae growth from "overfeeding" with phosphates



"Cage molecule" of zeolith A. The molecule consists of an aluminum-silicon framework that contains sodium ions. Its effect as a softener derives from an exchange of calcium ions for sodium ions (photo: Henkel).

Potassium permanganate solution (A) is bleached by hydrogen peroxide solution (B) and hydrogen peroxide-releasing laundry detergent (C), but not by mild laundry detergent (D).

TECHNOLOGY AND ENVIRONMENT



Advantages and disadvantages of modern laundry detergent

The laundry detergents used today hardly contain soap anymore. When they do, the soap serves less as a cleaner and more as a foam regulator. The molecules of synthetic surfactants, like those of soap, have a lipophilic and a hydrophilic zone, but, as your experiments showed, are not blocked by either hard or soft water.

But the use of synthetic surfactants doesn't render water softening completely irrelevant. Washing machines can get calcium deposits that can damage the heating elements in addition to leading to a higher energy consumption. Modern laundry detergents contain special softeners that not only capture and get rid of the harmful "hardeners," but also "break" the soap scum and heavy-metal soaps contained in the dirt and thereby make it easier for the surfactants to do their work.

For this purpose, it used to be common to use phosphates,

and they are still used to some extent, but they have undesired side effects. Along with the phosphate fertilizers used in agriculture, they lead to an over-fertilization of waterways. The water plants grow too vigorously and can no longer be broken down in natural ways. This results in putrefaction processes, and the waterway "dies." That is why other substances lacking these undesired effect, some of them (such as zeolites) known for a long time, are used as softeners. These substances make it possible to reduce the phosphate proportion of laundry detergents by quite a bit, and even to offer phosphate-free detergents.

The laundry detergents common today contain a lot of other additives, such as brighteners, fragrances, enzymes (to "digest" protein-containing stains), materials to make the detergent powder flow better, and — just in the case of the heavier-duty detergents — bleaching agents.

EXPERIMENT 252

Additional material: Regular laundry detergent

To the second test tube, add 2 spoon tips of a regular washing detergent, seal it with the stopper, and shake.

The foam that you get when you shake it looks bright white. The laundry detergent has bleached the potassium permanganate too. **A8**

EXPERIMENT 253

Additional material: Mild laundry detergent

Repeat the previous experiment with the final third of the potassium permanganate solution, but this time use a mild laundry detergent. The purple color of the potassium permanganate remains. **A7**

Regular laundry detergents usually contain materials that release hydrogen peroxide in the washing process. The hydrogen peroxide releases oxygen as it breaks down, and the oxygen bleaches the laundry. If you have sensitive, color textiles though, even the "milder" bleaching agents are not recommended. The gentle laundry detergents that have been developed for this purpose don't contain any hydrogen peroxide-releasing additives.

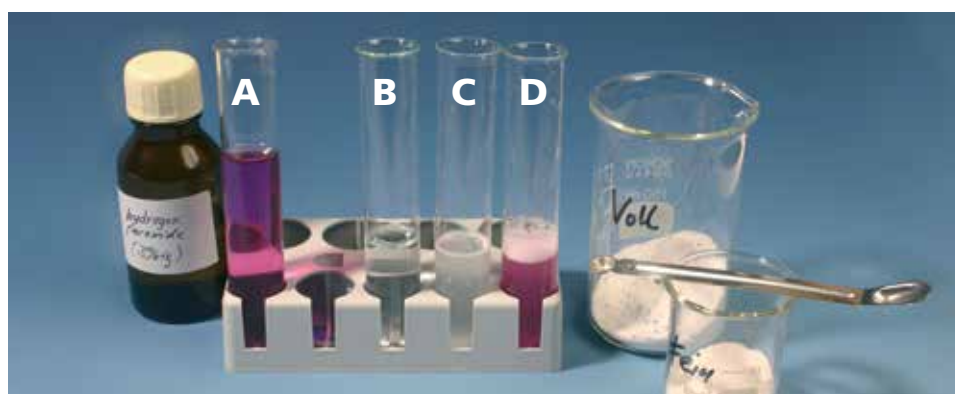

18

Luminol: The Cold Light

You have probably seen those colorful glow sticks that are used to enhance the mood at parties or outdoor events. If you have ever held one of those lights in your hand, you will know that it doesn't feel even a little bit warm as it glows. That's why it's referred to as a "cold light." In most cases, after all, the radiation of light is associated with heat. Think of flickering flames or of light bulbs, things that can really burn your fingers if you're not careful. And, of course, there's the sun, which provides us with both light and warmth.

But there are materials — such as the one in the glow sticks — that will emit light well below a temperature that would feel warm. Among them is luminol, which will be the final topic on your chemical discovery tour. Granted, this material won't burn so brightly or colorfully as the material in the glow sticks, but on the other hand it does have a more mysterious and magical appearance — sometimes a deep blue, other times a livid green. You will be able to experiment with luminol by altering the conditions under which it glows.

How to get the luminol to glow

Since you will only need tiny amounts of luminol for your experiments, we have mixed it with sodium sulfate, a substance that won't interfere with it. The actual quantity of luminol in it is very small, which wouldn't be enough to experiment with on its own in any case. Even mixed with sodium sulfate, all you will need is a spoon tip at a time. For the sake of simplicity, we will just refer to the mixture as "luminol."

To make the luminol glow, you will need an oxidizer. The first thing you can use is hydrogen peroxide, which you are already familiar with. As you will see, the reaction must occur in an alkaline solution and it requires a catalyst, since otherwise the glow would be extremely weak or wouldn't occur at all. As a catalyst, you can use potassium hexacyanoferrate(III), or red prussiate. But you will see that other catalysts will do the trick as well.

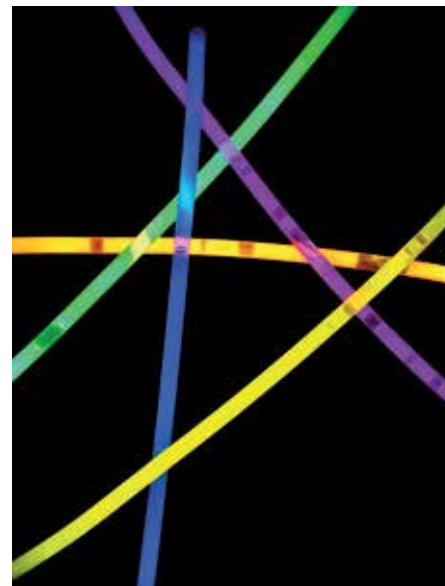

The blue glow after combining the two solutions (Experiment 254). The glow gets stronger when you throw in the catalyst (Experiment 255).



For luminol, sodium carbonate, and hydrogen peroxide, note the "Hazardous substances and mixtures" information starting on p. 7.

For the following experiments, you will need a *small screw-top jar* and *hydrogen peroxide*.

EXPERIMENT 254

Dissolve a spoonful of sodium carbonate in a test tube half-filled with water, seal the test tube with the stopper, and shake until the sodium carbonate is dissolved. Add

1 spoon tip of luminol, shake thoroughly once again, and fill up the test tube with water.

In a second test tube, dissolve 1 small spoonful of potassium hexacyanoferrate(III) in some water, add 2 cm of hydrogen peroxide, and fill with water again. Now, in a completely dark room, pour the two solutions together in a small screw-top jar. The mixture will glow blue-green. Alas, the glow will soon become weaker. You can restore its intensity by adding more potassium hexacyanoferrate(III).

The following experiment shows that luminol won't glow without the catalyst.

EXPERIMENT 255

Add 2 spoonfuls of sodium carbonate and 1 spoon tip of luminol to a test tube filled halfway with water. Shake the sealed test tube to dissolve the solid materials. After

adding 2 cm of hydrogen peroxide, you will often be able to observe a weak glow —

Side Notes

The alchemist's glowing beaker

Luminol — synthesized in 1902 — was not the first material produced in a lab that allowed people to study the phenomenon of cold light. The most important discovery in the field of luminescence — which is the technical term for the cold glow — was made over 200 years earlier, in the lab of the alchemist Hennig Brand (around 1630–1692).

You already heard that the alchemists had some ambitious plans. They were on the trail of the “philosopher’s stone” in order to get to the bottom of the secret of making gold.

Hennig Brand had the idea that the philosopher’s stone might be hidden in urine, which he boiled down in large quantities. After all this, what was left in his beaker was a white substance that glowed in the dark. He had discovered the element phosphorus, more specifically highly toxic white phosphorus (there is also a less toxic red version). Phosphorus is found in harmless compounds in bodies of humans and animals, particularly in phosphates. It is in this form that phosphorus is eliminated in the urine.

To oxidize white phosphorus, all you need is the oxygen in the air. In response to oxidation, you get the emission of light, a phenomenon to which phosphorus owes its name (Greek *phosphoros*: light-bearing).



Reproduction of the painting “The Alchemist in Search of the Philosopher’s Stone” (1771) by Joseph Wright of Derby

but only in complete darkness. Pour the contents of the test tube into the small screw-top jar filled halfway with water.

Now add 1 spoonful of potassium hexacyanoferrate(III) in small portions to the solution mixture (tap lightly on the handle of the measuring spoon with your finger, as the pros do). The crystals will leave trails of light as they sink in the liquid, which will shine with an increasingly green glow. If you lift up the jar and look at it from below, you will see still-undissolved crystals glowing blue on the bottom. This is where their concentration is the highest, and the reaction the strongest. As in the last experiment, you will be able to bring the fading light back to life by adding more potassium hexacyanoferrate(III).

Acid solutions won’t glow



For sodium hydrogen sulfate, sodium carbonate, luminol, and hydrogen peroxide, note the “Hazardous substances and mixtures” information starting on p. 7.

EXPERIMENT 256

In two test tubes holding 2 cm of water each, dissolve 2 spoonfuls of sodium hydrogen sulfate (in one test tube) and 2 spoonfuls of sodium carbonate (in the other). Place a pipette in each solution.

Now prepare the glowing luminol solution in a screw-top jar as you did in Experiment 254, and drip sodium hydrogen sulfate solution into it. The glow will get weaker and weaker, and eventually disappear. Now drip the sodium carbonate solution into the jar. Even the very first drops will create glowing clouds where they hit, but if you swirl the jar they will probably disappear again. As you add more sodium carbonate solution, the familiar luminol glow will return to the jar’s contents.

If you were to add more sodium hydrogen sulfate solution, it would make the glow disappear again, and adding more sodium carbonate solution would bring it back from the darkness. **A1**

EXPERIMENT 257

Additional material: Bath soap

Add some finely-shaved soap to a test tube filled halfway with water as in Experiment 242, and add 1 spoon tip of luminol. Shake the sealed test tube. You will get some foam, of course, but that won’t bother us. After adding 2 cm of hydrogen peroxide and 1 spoon tip of potassium hexacyanoferrate(III), seal the test tube again and shake (keep your thumb on the stopper, or it can easily slip out!).

The alkaline reaction of the soap solution (see Experiment 49) is enough to make the luminol glow. **A1**

What works with soap should also work with laundry detergent.

EXPERIMENT 258

Additional material: Regular laundry detergent

In a test tube filled halfway with water, dissolve 2 spoonfuls of laundry detergent and 1 spoon tip of luminol. Seal the test tube and shake. In a second test tube, dissolve 1 small spoonful of potassium hexacyanoferrate(III) in 2 cm of water. Add the hexacyanoferrate solution to the laundry detergent solution. Wow! What a beautiful glow! **A1**



Question 50. Why does the experiment work so well? Haven't we forgotten an important component?

Copper as catalyst

We already said that there are still a few things to discover with the luminol reaction catalysts. Red copper will also make the luminol glow, albeit only dimly at first.



For **copper sulfate** and **ammonium chloride**, note the "Hazardous substances and mixtures" information starting on p. 7.

EXPERIMENT 259

Prepare a sodium carbonate-luminol solution as in Experiment 254. In a second test tube filled halfway with water, dissolve a spoonful of copper sulfate, add 2 cm of hydrogen peroxide to it, and fill the test tube to the top with water. Pour both solutions into the small screw-top jar. Again, the mixture will glow bluish-green in the dark.

But soon, some dark, non-glowing clouds will start to form in the liquid. When you turn the light back on again, you will see a blackish-brown precipitate. This consists of copper oxide (like the precipitate in Experiment 188). Stir with the boiling rod and switch off the light again. The liquid will glow again for a little while, even if only weakly. **A6**



Apparently, nothing was left out of the laundry detergent cocktail after all.



Molecular model of luminol. In addition to 8 carbon atoms, 7 hydrogen atoms, and 2 oxygen atoms, the molecule contains 3 nitrogen atoms.

Basic Knowledge



From luminol to chemiluminescence

The most commonly used technical term for luminol — there is another one besides this — is **3-Aminophthalic hydrazide**. What a name! But it indicates that the compound consists of phthalic acid and the ammonia-like hydrazin, N_2H_4 . In addition, the molecule contains an amino group, or an NH_2 group such as the one you know from amino acids, of importance for its light intensity. But scientists believed that the mysteriously glowing substance deserved a simpler and prettier name, so they called it luminol — after Latin *lumen* = light, the same root also found in the technical term luminescence.

The picture of the molecule model shows two six-sided rings. The oxidation takes place in the ring with the two nitrogen atoms (blue spheres). By forming a bridge out of two oxygen atoms, which contribute to the oxidizing agent, a highly reactive, energy-rich intermediate stage arises. The breakdown of this intermediate stage leads to a doubly negatively-charged phthalic acid ion, which passes from an energetic "excited state" into the energy-poor "initial state." In the process, energy is released in the form of the blue glow.

The kind of glow that occurs, as here, through a chemical reaction is called **chemiluminescence**. It is different from fluorescence, by which materials simply convert radiation that they capture, such as changing invisible UV light into visible light. You may have seen minerals fluorescing under a UV light. People also recognized that luminol fluoresces even before they discovered its chemiluminescence.



Fluorescence of luminol when illuminated with UV light.



Testing for blood with luminol: The “thick” drops of blood won’t glow, while very small blood quantities released from the drops and spread out on the paper act as catalysts.

EXPERIMENT 260

In a test tube filled halfway with water, dissolve 2 spoonfuls of sodium carbonate and 1 spoonful of ammonium chloride, add 1 spoon tip of luminol, and shake the sealed test tube. If you add 1–2 cm of hydrogen peroxide, you will probably be able to see a weak glow. Now set the bare copper wire in the solution. After a few seconds, it will start to emit a blue glow around the wire. At the same time, some gas production will start and gradually grow stronger. Soon all the liquid will be glowing a beautiful blue, a stronger glow than in the previous experiments. After a little while, the brightness will quickly fade. If you add more hydrogen peroxide, the gas and accompanying blue glow will return for a little while. You can tell that copper passed into the solution from the wire by the solution’s blue color.

A4

Catalysts in blood and radishes

EXPERIMENT 261

Additional material: Blood from fresh steaks, hamburger meat, or fresh sausage

Drip the blood onto a paper towel, or press the meat or chopped-up sausage with a spoon in the graduated beaker to squeeze some out.

Add 2 spoonfuls of sodium carbonate and 1 spoon tip of luminol to 5 cm of water in a test tube. Shake the sealed test tube. After adding 2 cm of hydrogen peroxide, you will often be able to see weak glow, as in Experiment 255. In a darkened room, add the solution to the bloody paper towel or the sample in the graduated beaker. The “blood traces” will glow most brightly on the paper. A1, A3

Luminol has been, and still sometimes is, used by the police to detect blood traces. This method has the advantages that even old, dried blood residues can be identified conclusively, and that subsequent tests, such as genetic tests, won’t be compromised by the chemiluminescent reaction.

Why does blood act as a catalyst in luminol oxidation? Because the blood pigment hemoglobin contains an Fe^{2+} ion that is oxidized into an Fe^{3+} ion in the reaction. This ion, just as the one in potassium hexacyanoferrate(III), is critical for the catalytic effect.

EXPERIMENT 262

Additional material: Radishes, paper towel

Cut a large radish into 3 to 4 slices and place them on a paper towel. Prepare a sodium carbonate-luminol-hydrogen peroxide solution as in the previous experiment, and drip the solution onto the radish slices. A1, A3

Horseshoe and red and white radish varieties contain peroxidases. Those are enzymes that facilitate the oxidation of other substances by hydrogen peroxide, in this case the oxidation of luminol. As with hemoglobin, these are proteins in which an Fe^{3+} ion is stored. Compounds of this type that have a metal ion stored in them are called complex compounds (Latin *complexus* = enclosing, embracing).

In the two experiments you just carried out, try using a solution made of laundry detergent and luminol instead of the sodium carbonate-hydrogen peroxide solution. In some cases, certain ingredients in the laundry detergent will intensify the glow, as in Experiment 258.



The peroxidases contained in radishes facilitate the oxidation of luminol by hydrogen peroxide.



Fireflies and luminous bacteria

Have you ever seen those greenly-shimmering points of light dancing around on a summer evening? Those are fireflies, sometimes also called glowworms, although they really aren't either flies or worms. Strictly speaking, they are beetles, one of the *Lampyris* genus such as the European *Lampyris noctiluca* shown on the right. The Chinese were already pondering this little creature 3,500 years ago. Today we know that fireflies and glowworms hold certain substances known as luciferins in their abdomen, which are oxidized with the help of enzymes. Then, the oxidized intermediate stage breaks down with a release of energy that shows itself as light. Luciferins (Latin *lucidus* = full of light, shining), in other words, work by the same principle as luminol.

But glowworms and fireflies are responsible for a mere fraction of the cold light found in nature. In particular, the ocean is not as dark as you might think. There are luminous deep-sea fish there, and

glowing crabs and jellyfish. Luminous bacteria settle on dead fish and make the dead matter light up. Another fascinating phenomenon is the marine phosphorescence that occurs in certain regions, likewise produced by unicellular plant and animal organisms. All of these phenomena are included under the term bioluminescence. In terms of chemistry, bioluminescence is a branch of chemiluminescence. That was obvious with the luciferin example.

Chemiluminescence and bioluminescence, meanwhile, have been found to have some practical applications. Luminol can be used to detect particularly reactive oxygen particles — reactive oxygen species — in human and animal bodies. They play an important role in inflammations, arterial plaque, and cancers. Luminous bacteria have also been put to use recently for wastewater monitoring. The brighter they shine, the cleaner the water is. If their light goes out, there's imminent danger — and not just for the bacteria.

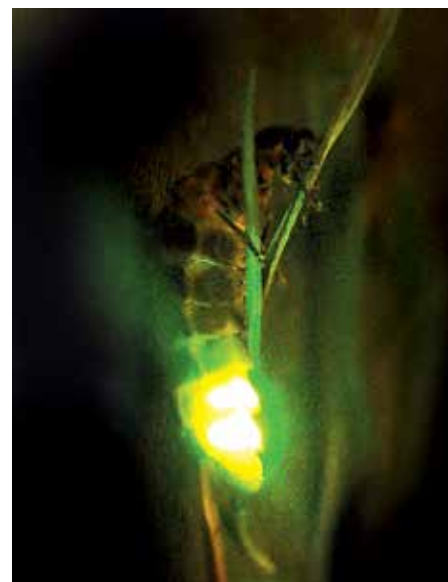

Checking wastewater with luminous bacteria (Bayer AG)

Blue lightning and starry skies

After this detour into living nature, let's get back to luminol, which we will leave after three tricky experiments.



For **sodium carbonate**, **luminol**, and **hydrogen peroxide**, note the "Hazardous substances and mixtures" information starting on p. 7.

EXPERIMENT 263

Additional material: 9-volt square battery, aluminum foil
Make your preparations in a brightly lit room. First, you will carry out the electrolysis of a table salt solution as in Experiment 107. Time

required: about 20–30 seconds. Unlike in the previous experiment, stir the contents of the beaker with the boiling rod this time as the current is passing through.

In this process, the electrolysis products chlorine and sodium hydroxide are combined into sodium hypochlorite, a compound that smells of chlorine (sniff briefly, but don't inhale). You will need the sodium hypochlorite solution (Caution! It irritates the skin) for the actual experiment.

In the second beaker, dissolve 5 spoonfuls of sodium carbonate and a spoon tip of luminol in 50 ml of water (put the lid firmly over the beaker and shake well). Darken the room to the point that you can barely see the beaker. Now use a pipette to add the sodium hypochlorite solution drop by drop to the luminol solution. Each drop triggers a little blue flash or blue cloud in the luminol solution. A1

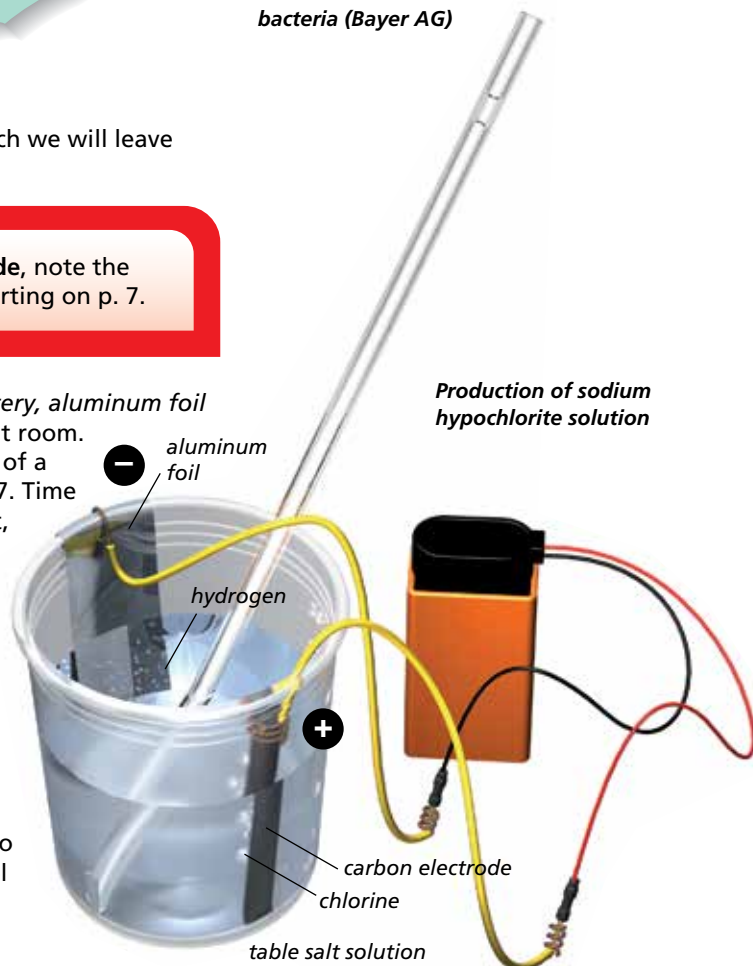

Production of sodium hypochlorite solution



One yellow, one red: the two prussiates

In this experiment, the hypochlorite solution acts as both oxidizing agent and catalyst, so it's replacing the potassium hexacyanoferrate(III) and hydrogen peroxide.

EXPERIMENT 264

Additional material: *As in the previous experiment*

Thoroughly rinse out both graduated beakers and set up one for electrolysis as in the previous experiment. In the second beaker, dissolve 3 spoonfuls of sodium carbonate and 1 spoon tip of luminol in 50 ml of water. Then add 3 cm of hydrogen peroxide (from the test tube) to it. We're still missing a catalyst. Would yellow prussiate, potassium hexacyanoferrate(II), do the trick?

Dissolve 1 spoonful of the yellow crystals in a test tube with 3 cm of water and add the solution to the luminol solution. Darken the room! Nothing happens.

Pour the contents of the beaker into the electrolysis beaker and close the circuit (the carbon electrode is always connected to the positive terminal in these experiments). If you now darken the room again, you will see a bluish shimmer around the carbon rod. Gradually, the entire contents of the beaker will start to glow softly but distinctly. The liquid will also glow after you switch off the current, probably longer than in the other experiments. What happened? The catalytically ineffective potassium hexacyanoferrate(II) has been oxidized by the current into effective potassium hexacyanoferrate(III). Oxidized? Yes, you already know (Basic Knowledge, p. 56) that the pros understand oxidation to refer to an increase in charge. Fe^{3+} red prussiate ions were created from the Fe^{2+} yellow prussiate ions: an increase from 2 to 3. **A1**

Finally, let's end with something fun: You will be staging a starry scene — the heavenly glow of luminol — in a basin (it shouldn't be too small) or bathtub.

EXPERIMENT 265

Additional material: *Regular laundry detergent*

Place 3 to 5 spoonfuls of laundry detergent, 1 spoonful of potassium hexacyanoferrate(III), and 1 small spoonful of luminol in a dry (!) graduated beaker. Seal the beaker with its lid and shake thoroughly (keeping the lid pressed firmly on the beaker). Pour the mixture onto a sheet of writing paper and, tapping the paper lightly, sprinkle the mixture over as broad a surface area of the basin or tub as possible (the basin or tub has to be damp, but there can't be any water standing in it).

Great! Depending on your sprinkling skill, you will get a sparkling, starry sky or a Milky Way- or galaxy-like display. The largest of the stars will have a blue glow (potassium hexacyanoferrate crystals). Zones of medium concentration will appear green, and thinly populated regions will glow pale white. When you have had enough of your starry sky, turn on the water tap — still keeping the lights off, though. All the magnificent light will pull away in streaks and disappear into a black hole — the drain. Now you've taken care of the clean-up and disposal too. Rinse well afterwards!

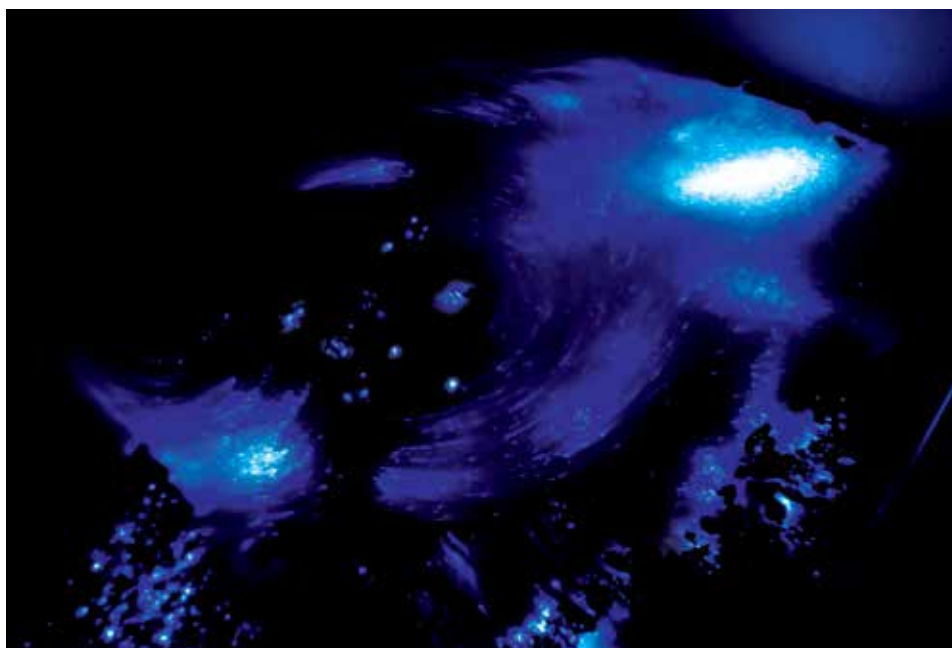

There are no limits placed on your imagination when reading the night sky.

19

How to Dispose of Waste

Do the chemicals in this kit and the reaction products created in the experiments represent a danger to the environment?

Since you will usually be working with very small amounts of relatively safe materials, any environmental pollution caused by you and other chemistry hobbyists like you will be relatively slight. In many cases, you can just pour the residues and reaction products down the drain. But you should always be sure to rinse the sink with plenty of water afterwards, so nothing remains behind in the sink.

Some of the chemicals in the kit require special disposal procedures that you should be familiar with. These have to do with:

- Acids and bases. Strong solutions must be neutralized before being poured down the drain.
- Certain heavy metal compounds and iodine must be separated out as insoluble substances or converted into less harmful compounds.

At the end of each experiment in green letters, you will find an indication of which of the following disposal instructions A1 through A9 is to be used. If a reaction product created in an experiment is needed for further experiments, the disposal instructions will be found at the later location. If only non-hazardous household materials are used, no disposal instructions are indicated.

Disposal instructions A1 through A9



For **sodium carbonate**, **sodium hydrogen sulfate**, and **hydrogen peroxide**, which you will need for some of the disposal measures, note the "Hazardous substances and mixtures" information starting on p. 7.

Acids and bases (alkalis)

Any solutions containing just a little of an acid or base may be poured directly down the drain. The same applies to all materials that are neutral, or that only slightly endanger the water system. In all such cases, you will see the code **A1**.

A1 Pour down the drain and rinse.

Strongly acidic or alkaline solutions should first be neutralized, using litmus as an indicator (see Experiment 67). Acid solutions can be neutralized with sodium carbonate or laundry detergent (added in small portions), just until the solution just turns blue. To an alkaline solution, add vinegar until the blue color turns to red. Then pour the neutralized solution down the drain.

A2 Neutralize the solution and pour it down the drain.

Solid materials that will not dissolve easily

Residues of iron filings, plaster, and filtered-out precipitates of copper and manganese compounds (e.g. copper oxide, copper hydroxide, manganese oxide) can be disposed of in the garbage can (not the kitchen trash container) at the end of the experiment.

A few general tips

Filter paper or paper towels on which you have dripped solutions in order to obtain a chemical reaction may be added to the household garbage. Wear protective gloves.

You can have an adult assistant return undiluted **denatured alcohol** to the storage container. The alcohol-water mixture that you used as a solvent (Experiments 200 ff.) should be rinsed down the drain with plenty of water.

If you end up with storage vials containing small quantities of **leftover chemicals** that you no longer need, ask an adult to take the vials to a hazardous waste disposal facility. There, they will be sorted and disposed of in an appropriate manner along with other laboratory waste.

Our instructions for waste disposal conform to the Safety Guidelines for Natural Science Curricula recommended by the German Cultural Ministry Conference, in particular as they relate to wastewater and household garbage disposal.

A3 Add to household waste.

Solutions containing copper

With soluble copper compounds (such as copper sulfate solution), metallic copper can be precipitated out of the solution by adding iron (the reaction involved here is the same as the one in the first step in Experiment 162); the copper will do no harm if added to the household garbage. The soluble iron compounds created in that conversion process are less harmful to the water supply than copper compounds. To precipitate out copper, the best thing to use is steel wool.

A4 Vigorously shake the (light blue to clear) solution a while in a sealed test tube with some steel wool. Pour the liquid down the drain, and add the sediment to the household garbage.

Dark blue alkaline-reacting solutions (copper-ammonia solution, Fehling's solution used as a test for glucose) must first be acidified, for example with vinegar.

A5 Add a little acid to the (dark blue) solution until it turns light blue, then A4.

Hard-to-dissolve copper and manganese compounds

With several of the experiments, you will get precipitates of copper and manganese compounds, which you can simply dispose of in the household garbage.

A6 Filter off precipitates, dispose of both precipitate and filter in the household garbage, pour filtrate down the drain.

Soluble manganese compounds

Permanganate and manganate (purple or green solutions) can be converted into a relatively insoluble compound, which you can filter off and dispose of in the household garbage.

Concentrated solutions should be converted into relatively insoluble manganic acids, which can be disposed of in the garbage.

A7 In the screw-top jar, treat the violet or green solution with 1 small spoonful of sodium hydrogen sulfate and a little hydrogen peroxide. Swirl the solution in the jar and add sodium carbonate to the clear solution. Filter off the dark brown precipitate and dispose of it in the garbage; dilute the filtrate and pour it down the drain.

In a few experiments, you will end up with the colorless manganese compound that occurs as an intermediate stage in A7.

A8 Treat the solution with sodium carbonate. Filter off the dark brown precipitate and dispose of it in the garbage; dilute the filtrate and pour it down the drain.

Iodine

At the end of the experiments with iodine solution, the iodine will be converted into less-harmful iodide, which can be poured down the drain. Any unused leftover iodine solution can be handled in the same way.

A9 Treat yellow, brown, or blue (iodine-starch) solution with vitamin C solution until it turns clear, and pour it down the drain. You can make the vitamin C solution by dissolving vitamin C powder or crushed vitamin C tablets in water.

20

Answers to the Questions

1. Answers will vary, but some “popular” chemicals are water, carbon dioxide, salt (sodium chloride), sugar, oxygen, gasoline (hydrocarbons), iron, steel, and aluminum.

2. By stirring it with a spoon.

3. An unsaturated solution can still absorb more of the dissolved material.

4. The dissolved table salt was able to pass through the fine pores of the filter paper without any problem, and was able to be detected by evaporating the filtrate.

5. Pumping a bicycle tire.

6. Mercury is about 13.5 times heavier than water. That means that the relatively short column of mercury is able to balance the weight of air pressure as well as that of a 10-meter column of water.

7. The air contracts when cooled. A vacuum arises in the test tube, and the external air pressure pushes the liquid back into the test tube.

8. The one with the boat lift (Experiment 35).

9. The reaction equation is wrong: On the left, you see two chlorine atoms or 1 Cl_2 molecule, to the right you have 2 MgCl_2 , containing 4 chlorine atoms. The correct equation would be: $\text{Mg} + \text{Cl}_2 \rightarrow \text{MgCl}_2$.

10. Add 10 drops of vinegar to 2 cm of water, divide the solution between two test tubes and add 3 spoonfuls of sugar to one of them. Test both solutions with litmus solution.

11. One could incorrectly conclude that calcium hydroxide is insoluble in water.

12. In the spot where the drop falls, there is a temporary excess of acid (red coloring). As long as more alkali than acid is present, though, the blue color will return as soon as the liquid is mixed evenly.

13. The color change — that is, the change from red to blue and vice versa — is easier to see with a white backdrop.

14. The name. An oxide is a compound with oxygen. Carbon dioxide is a compound of the elements carbon and oxygen.

15. The heat of the flame makes the carbon dioxide “lighter,” or to be more precise: its density is reduced. It rises into the test tube and displaces some of the air there.

16. The smoking of the candle; when that happens, black smoke rises up.

17. That carbon dioxide is created in the body and exhaled through the lungs.

18. $\text{H}_2\text{SO}_4: \text{H}_2\text{SO}_3$ (sulfurous acid) + $\text{O} \rightarrow \text{H}_2\text{SO}_4$ (sulfuric acid)

19. The nails become covered with a dark coating. When you open the jar, it smells like rotten eggs (hydrogen sulfide).

20. The hydrogen chloride dissolved in the water on the damp anthocyanin paper.

21. Water.

22. An alkaline-reacting substance has been created at the positive terminal.

23. 1–2 drops of vitamin C solution will make the “charcoal streak” disappear. Try it with an actual pencil mark.

24. That no acid gets into the limewater.

25. Add some acid (e.g., vinegar) to a small sample. If no gas develops (foaming), it’s table salt. Otherwise, the “rubbing test” will determine whether it’s sodium carbonate or sodium hydrogen carbonate (dissolve 1 spoonful of the substance in 1 cm of water).

26. Because the gases in the hot test tube contract during cooling, so cold limewater can rise back into the still fairly hot test tube, which would make it shatter.



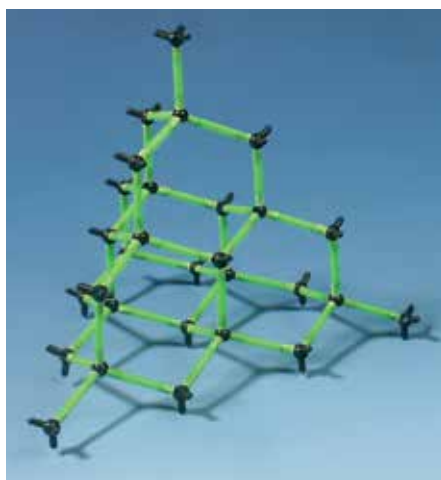

27. Experiments 67 and 68, practical examples of neutralization.

28. Carbon dioxide converted the calcium carbonate precipitate into a soluble material.

29. That the store-bought powdered plaster also contains water.

30. Ice (solid) — water (liquid) — water vapor or steam (gas).

31. There could still be bits of the alkaline-reacting calcium hydroxide sticking to the glass wall.

32. In disposal method A4: Precipitate of copper from copper compounds.

33. That iron is present in the red rock as iron(III) compounds.

34. Prussian blue is not stable in an alkaline solution. You can only use the Prussian blue reaction to test for iron in acidic solutions, not alkaline ones.

35. Observation: The nail is covered with a bright red coating. Assumption: It's copper. Conclusion: When copper is heated with sodium hydrogen sulfate, it creates a soluble copper compound.

36. Experiment 155: Blue invisible ink.

37. That denatured alcohol contains some water. The water portion is about 10–30%, depending on the specific alcohol you are using.

38. He or she will have to place a piece of filter paper soaked in potassium hexacyanoferrate(II) solution over the secret message. The writing will be visible as Prussian blue (here and with answers 39 and 40, use the solution prepared in accordance with the tip on p. 83).

39. Paper soaked in potassium hexacyanoferrate(II) solution. The ink consists of copper hexacyanoferrate(II).

40. Just as with potassium hexacyanoferrate(II) solution (add 1 drop of hydrogen peroxide solution if necessary).

41. The writing paper softens at the spot where it dips into the water.

42. The water rises up in the filter paper.

43. "Paint" the circle with the homemade iron(III) sulfate solution. After it dries, slowly drip potassium hexacyanoferrate(II) solution onto the center of the circle. You probably won't get the entire circle at once. You can compete with some friends to see who does it best.

44. Because the mixture of citric acid and sodium carbonate would foam up so strongly that some of the substance would be lost.

45. There could already be simple sugars in the sweet baked goods, so the chewing test wouldn't prove anything.

46. Singed hair.

47. Maybe when you washed your hands you didn't rinse off all the soap.

48. Only the free calcium ions from the soluble calcium hydrogen carbonate form soap scum, not the calcium ions bound to the hard-to-dissolve calcium carbonate.

49. Because there is no calcium compound in the reaction mixture.

50. Nothing was forgotten at all. As you know from Experiment 252, regular laundry detergent contains substances that release hydrogen peroxide. This "fixed" hydrogen peroxide replaced the 3% solution in this case as well. And you didn't need sodium carbonate, since regular laundry detergent has an alkaline reaction.

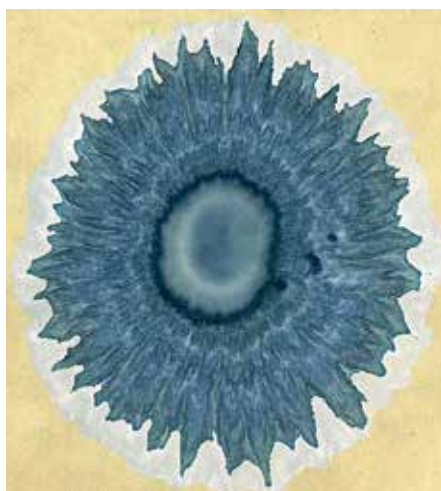

- 3-Aminophthalhydrazide 119
 Acetic acid, molecular model 108
 Acid rain 58
 Acid residue 42
 Acid strength 44
 Acidic reaction 38 ff.
 Acids 36 ff.
 –, strong, weak 54
 Additional materials 14
 Aggregate states 78
 Air 26 ff.
 –, pollutants 58
 –, expansion when heated 27 f.
 –, composition of 29
 Air pressure 27
 Alchemists 82, 118
 Alcohol (ethanol, ethyl alcohol) 8
 Alcohol burner 12/13
 Alcoholic fermentation 48
 Alkaline 36
 Alkaline reaction 38
 Alkalis 36 ff.
 Allotropes 50
 Alloys 31
 Aluminum foil 14, 24, 62/63, 91, 95
 Amino acids 106, 108
 Amino group 108, 119
 Aminoacetic acid 107/108
 Ammonia 79 ff.
 Ammonia spirits 80
 –, making 80 f.
 Ammonia synthesis 79
 Ammonia-soda method 66
 Ammonium carbonate 7, 82
 Ammonium chloride 8, 17, 77 ff.
 Ammonium hydrogen carbonate 8, 82
 Ammonium hydroxide 80
 Analysis 90
 Anthocyanin paper 40
 Anthocyanin solution 40
 Anthocyanins 39
 Ascorbic acid (vitamin C) 14, 62, 64
 Atoms 30
 Azurite 88
- Baking powder 68 f.
 Baking soda 14, 22 f., 44, 49, 65 ff.
 Barometer 27
 Bases 36 ff.
 Bee honey 193
 Beet sugar 102
 Bioluminescence 121
 Biotechnology 39, 48
 Biuret reaction 107
 Blast furnace 84 f.
 Bleaching agent 115 f.
 Blood, testing for 120
 Blotting paper 96
 Bosch 80
 Boyle 23
 Brand, Hennig 118
 Burette 45
 Butter 109
- Calcium 71
 Calcium deposits 71 f.
 Calcium hydrogen carbonate 73
 Calcium hydroxide 8, 24, 42 ff.
 Calcium sulfate 74, 114
 Cane sugar 102
 Capillaries 96
 Carbohydrates 101
 Carbon 50, 100 f.
 – cycle 51
 Carbon dioxide 46 ff.
 – density 48
 –, test for 46
 – combustion products 49 ff.
 Carbon dioxide snow 47
 Carbonate ion 48
 Carbonic acid 48
 Casein 109
 Catalase 32
 Catalysts 32, 117 ff.
 – in automobiles 32, 58
 Catalytic converters 58
 Cellulose 101
 Cement 71
 Cheese 109 f.
 Chemiluminescence 119
 Chemistry 10
 Chloralkali electrolysis 64
 Chloride ions 60 ff.
 Chlorine 35, 42, 61 ff.
 –, bleaching effect 62 ff.
 –, making
 Chlorine chemistry 64
 Chlorofluorocarbons (CFCs) 64
 Chromatography 98
 Circular chromatography 99
 Citric acid 8, 14, 36 ff.
 Combustion processes 28 ff.
 Complex compounds 120
 Compounds, chemical
 Concentration 21
 Conductivity (salt solution) 63
 COOH group 108
 Copper 88 ff.
 –, dissolving 89
 –, native 88
 –, test for 90
 –, refining 91 f.
 Copper carbonate, basic 93
 Copper oxide 89, 93
 Copper sulfate 9, 17, 19, 83, 90
 –, water of crystallization content 92
 Cream 109
 Crystal lattice 30
 Crystallization 18 f.
- Dalton 30
 Davy 31
 Decanting 19
 Democritus 30
 Denatured alcohol 8, 12/13, 36, 40, 50, 89, 97, 100
 Density 17
 – of gases 48
 Desublimation 78
 Diamond 50
- Disposal 123
 Distillate 22
 Distillation 21
 Dry ice 47
 Dyes, separation of 97 ff.
- Effervescent powder 70
 Egg white 106
 Egg yolk 106
 Electrolysis 23
 – on paper 95
 – of iodide solution 64
 – of table salt solution 62 f., 121
 – of water
 Electrolytic copper 92
 Electropotential series of metals 85
 Elementary particles 30
 Elements, chemical 22 f.
 Empedocles 23, 26, 28
 Emulsion 109, 112
 Environmental pollution 16, 46 ff., 52 f., 57 f., 64, 116
 Enzymes 105, 106
 Evaporation 18 f., 78
 Evaporation 20, 60
 Exhaust catalyst 32
- Fat 112 f.
 Fatty acids 113 ff.
 Fehling 102
 Fehling's solution 102
 Filter paper 19
 Filtrate 19
 Filtration 19
 Fireflies 121
 Flash powder 29, 31
 Fluorescence 119
 Forest dieback 16, 58
 Formulas, chemical 35
 Fountain experiment 61
 Fructose 103
 Fuel cells 25
 Fullerenes 50
- Galvanic series of metals 85
 Gentle washing detergent 115 f.
 GHS system 7
 Glass tubes, handling 13/14
 Glow sticks 117
 Glucose 101 f.
 –, test for 101
 Glycin (aminoacetic acid) 107/108
 Graphite 50
 Greenhouse effect 52
 Groundwater level 16
 Guericke 27
 Gypsum 14, 74 ff., 114
- Haber 80
 Hartshorn 8, 81 f.
 Hazardous substances and mixtures (chemicals) 7 ff.
 Heat expansion 27 f.
 Heavy metals, toxic effect of 106
 Helium 25
 Hemoglobin 120
- Hofmann 23
 Household sugar 101 f.
 Hydrochloric acid 42, 59 f.
 –, making 60
 Hydrogen 22 ff.
 –, making 24, 41
 –, as fuel 25
 Hydrogen chloride 42, 59 ff.
 –, fountain 61
 Hydrogen ions 42 f.
 Hydrogen peroxide 9, 14, 32
 –, bleaching effect 115
 Hydronium ions 43
 Hydroxide ions 43
- Indicators 36 f.
 – in fruits and vegetables 39 f.
 Ink 28, 97 ff.
 Insulin 107
 Invert syrup, making 103
 Invisible inks 81, 94 f.
 Iodine 8, 55
 Iodine paper 62
 Iodine solution (Betadine®) 8, 55, 62, 64, 104
 Ion lattice 30, 42
 Ion migration 63
 Ions 30, 42
 Iron 83 ff.
 –, making 84 f.
 –, test for 84
 –, combustion of 30
 Iron(III) sulfate solution 83 ff.
 –, making 83
- Keratins 108
- Lactic acid 109
 Lactose 102, 110
 Lactose 110
 Laundry detergent additives 115 f.
 Lavoisier 23, 31
 Leavening agent 68, 82
 Liebig 42
 Lime 71 ff.
 – burnt 71
 – slaked 71
 Lime mortar 71
 Limewater 8, 42 f., 46
 – making
 Litmus paper 38
 Litmus solution 36 ff.
 Luciferins 121
 Luminescence 118
 Luminol 9, 117 ff.
 Luminous bacteria 121
- Macromolecules 105
 Magdeburg hemispheres 27
 Magnesium 9, 31, 41
 – alloys 31
 –, combustion 29
 Magnesium oxide 31
 Malachite 88, 93
 Manganese 33
 Marble 72

Marggraf 102
 Marine phosphorescence 121
 Materials 10
 Meat protein 109
 Metal lattice 30
 Metals, precious and non-precious 85
 –, combustibility 29
 Methylated spirits 8, 12/13, 36, 40, 50, 89, 97, 100
 Milk 109 f.
 Milk of lime 42
 Mixtures 7, 16
 Modification 50, 118
 Molecular model 55, 79, 103, 108, 113, 119
 Molecule 30

 Neutralization 43
 Nitrogen 29, 78 f., 107 f.

 Overfertilization of rivers 116
 Oxidation 31, 56, 85, 117 ff.
 Oxidation number 85
 Oxide 31
 Oxidizer 64, 117
 Oxygen 22 f., 29 ff.
 –, making 22, 32 f.
 –, test for 32 ff.
 Ozone layer, destruction of 64

 Palmitic acid 113
 Paper chromatography 94 ff.
 Patina 93
 Peptide hormone 106
 Peptides 106
 Peroxidases 120
 pH scale, pH value 44
 Pharaoh's snakes 100
 Phosphates 116, 118
 Phosphorus 118
 Phosphoric acid 36, 39
 Plaster 14, 74 ff., 114
 Pollutants in the air 52, 58
 – in the water 116
 Potash 70, 113
 Potassium 33
 Potassium carbonate 36, 70, 95, 113
 Potassium hexacyanoferrate(II) 8, 17, 83 ff.
 Potassium hexacyanoferrate(III) 8, 117, 122
 Potassium permanganate mixture 8, 33
 Precipitate 46
 Protein 106 ff.
 – needs of humans 110
 Proteins 106, 108, 120
 Prussian blue 15, 83
 Prussiate, red 117 ff.
 Prussiate, yellow 17, 83 ff., 98, 122

 Reaction equation 35
 Reactive oxygen species 121
 Reduction 56
 Rennet 110
 Rock salt 59
 Rotliegend 86
 Runge 99
 Runge pictures 99

 Rust, formation of 31
 –, test for iron in 86
 Safety glasses inside back cover
 Safety information 6/7
 Sal ammoniac 77
 Salts 36, 42
 Scanning tunneling microscope 30
 Sea salt 59
 Silk 107
 Soap 111 ff., 118
 Soap scum 113 f.
 Soda water 70
 Sodium 65
 Sodium bicarbonate 14, 22 f., 44, 49, 65 ff.
 Sodium carbonate 9, 16, 37 ff., 65 ff.
 Sodium chloride 18, 35, 42, 59 ff., 62 ff.
 Sodium hydrogen sulfate 9, 56 f., 86, 89 f.
 Sodium hydroxide 43 f., 64
 Sodium hydroxide, making 43
 Sodium hypochlorite 121
 Sodium vapor lights 65
 Softener 114
 Solution 16
 –, saturated 17
 –, unsaturated 18
 Solvay 66
 Soot 50
 Sparkling water 46 ff.
 Stalactite formation 73
 Standard solution 45
 Starch 101, 104 f.
 –, test for 104
 –, splitting 104 f.
 States of matter 78
 Staudinger 105
 Steel production 84 f.
 Streak formation 17
 Sublimate 78
 Sublimation 78
 Sucrose 102
 Sugar 100 ff.
 –, reducing 102
 Sulfur 9, 54 f., 108
 –, molecular model 55
 Sulfur dioxide 30, 34 f., 54 ff.
 –, bleaching effect of 57
 Sulfur trioxide 56, 90
 Sulfuric acid 56
 Sulfurous acid 54 ff.
 Surface tension 111
 Surface water 16
 Surfactants 112 ff.
 –, synthetic 114
 Symbols, chemical 23, 35
 Synthesis 79

 Table salt 18, 35, 42, 59 ff., 62 ff.
 Tartaric acid 39
 Thermometer 27 f.
 Titration 44 f.

 Vinegar (acetic acid) 37
 Vitamin C see Ascorbic acid

 Washing detergent 115 f., 122
 Washing soda 65 ff.
 Waste disposal 123 ff.

 Waste water control 121
 Water 11, 16 ff.
 –, as solvent 16 ff.
 –, for washing 112
 –, and fat 112
 –, distilled 21
 –, softening 114 f.
 –, demineralized 113
 –, softening with surfactants 112
 –, hard 74, 113
 –, test for 92
 –, pollution of 16, 121
 Water of crystallization 75, 92
 Waters, overfertilization of 116
 Whey 109 f.
 Work area 11

 Yeast 32

 Zeoliths 116



Kosmos Quality and Safety

More than one hundred years of expertise in publishing science experiment kits stand behind every product that bears the Kosmos name. Kosmos experiment kits are designed by an experienced team of specialists and tested with the utmost care during development and production. With regard to product safety, these experiment kits follow European and US safety standards, as well as our own refined proprietary safety guidelines. By working closely with our manufacturing partners and safety testing labs, we are able to control all stages of production. While the majority of our products are made in Germany, all of our products, regardless of origin, follow the same rigid quality standards.

Instructions for use for the safety goggles (Art.-Nr. 717019)

Manufacturer Frame: Georg Schmerler GmbH & Co. KG / Reitweg 7 / 90587 Veitsbronn / Germany

Manufacturer Lens: IPB NV / Steenovenstraat 30 / 8790 Waregem / Belgium

Certification Office: ECS GmbH – European Certification Service / Hüttfeldstr. 50 / 73430 Aalen, DE / Germany / Notified Body Number: 1883

GSF – Safety goggles comply with the Regulation (EU) 2016/425 on personal protective equipment (PPE), are design tested, and bear the CE symbol. The Model 610 in this kit is suitable for protection against mechanical dangers.

Identification of the frame:

GSF = Code letter of manufacturer

166 = Number of the standard

S = increased robustness

CE = EC Conformity symbol

Identification of the safety lenses:

IPB = Code letter of manufacturer

1 = Optical class

S = increased robustness

If frame and lens have differing certification marks in regards to S, F, B, or A, the lower of the two applies. Wearers with extremely sensitive skin may experience allergic reactions upon contact with some materials. There are no spare parts or additional components available for this model. If damaged please discard the safety

goggles and discontinue use. Eye protectors used for protection against high-speed particles that are worn over standard ophthalmic spectacles may transmit impacts, thus creating a hazard to the wearer. If protection against high-speed particles at extreme temperatures is required then the selected eye protector should be marked with the letter T immediately after the impact letter, i.e. FT, BT, or AT. Otherwise the eye protector should only be worn and used at room temperatures.

Accessories: No accessories are available for this product.

Storage: Store in a dry and dust free place at room temperature.

Cleaning: Clean with clear water and household detergent. (Do not use solvents!) Avoid strong scrubbing as it can cause scratches.

Disinfection: Product can be disinfected with all regular commercial disinfectants.

Disposal: Pay attention to national regulations when disposing.

Length of usage: Do not use longer than 5 years after purchase date.

Warnings: Dispose of the goggles immediately if damaged. Only use eye protection lenses with optical class 1. Do not repair damaged safety goggles.

Limitations of use: These safety goggles in particular are not suitable for high-speed particles (e.g. cartridge tools), laser beam, temperatures above 55 °C, stray light arches, fusion metals, infectious substances, or organisms.

Declaration of Conformity: A Declaration of Conformity according to Regulation (EU) 2016/425 on PPE and the Directive 2001/95/EC on general product safety is available for this product on the following web address: <http://thamesandkosmos.com/declarations/declaration-717019.pdf>

